

Quiet 100 Duo T



Axial exhaust fans Quiet feature low noise and high performance

- Maximum airflow: 90
- Sound pressure level LpA at 3 m: 25
- Motor type: AC
- Casing material: Polypropylene/Thermoplastic elastomer
- Backdraft protection: Backdraft damper
- Timer: Turn off timer

	Unit of measurement	Quiet 100 Duo T	
Connected air duct size	mm	100	
Speed	-	2	
Minimum supply voltage	V	220	
Maximum supply voltage	V	240	
Power supply frequency	Hz	50/60	
Rated power	W	4.5	7
Unit current	A	0.029	0.052
Maximum airflow	m ³ /h	60	90
Sound pressure level LpA at 3 m	dB(A)	22	25
Weight	kg	0.55	
Ambient air temperature min	°C	1	
Ambient air temperature max	°C	45	
Ingress protection rating	-	IP45	

Dimensions

ØD	B	H	L	L1
99	158	136	81	26



Ecodesign

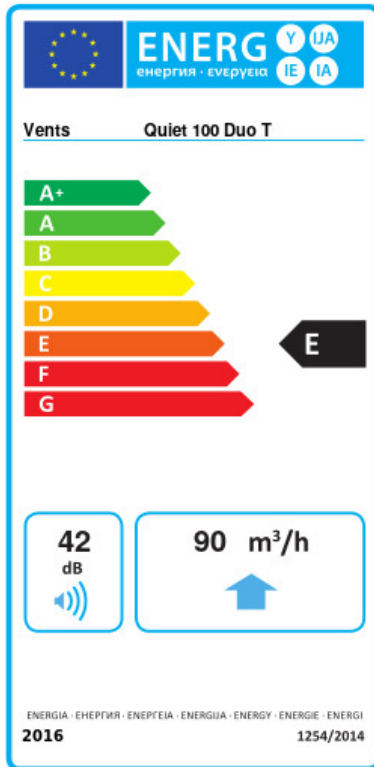

Trademark	Vents					
Model	Quiet 100 Duo T					
Specific energy consumption (SEC) (kWh/(m ² /a))	Cold		Average		Warm	
	-34.5	A	-16.5	E	-6.3	F
Type of ventilation unit	Unidirectional					
Type of drive installed	2-speed					
Type of heat recovery system	None					
Maximum flow rate (m ³ /h)	90					
Electric power input (W)	7					
Reference flow rate (m ³ /s)	0.017					
Specific power input (SPI) (W/(m ³ /h))	0.075					
Control typology	Clock control					
Maximum external leakage rates (%)	2.7					
Declared typology	RVU UVU					
Sound power level (dB(A))	42					
The annual electricity consumption (AEC) (kWh/a)	Cold		Average		Warm	
	88		88		88	
The annual heating saved (AHS) (kWh/a)	Cold		Average		Warm	
	3667		1874		848	