

# Quiet-Disc 125 T



Axial exhaust fans Quiet-Disc feature low noise and high performance. Another feature they have is high water ingress protection rating IP45, which allows them to be installed in humid premises

- Maximum airflow: 185
- Sound pressure level LpA at 3 m: 32
- Motor type: AC
- Casing material: Plastic
- Backdraft protection: Backdraft damper
- Timer: Turn off timer

	Unit of measurement	Quiet-Disc 125 T
Connected air duct size	mm	125
Speed	-	1
Minimum supply voltage	V	220
Maximum supply voltage	V	240
Power supply frequency	Hz	50
Rated power	W	17
Unit current	A	0.11
Maximum airflow	m <sup>3</sup> /h	185
Sound pressure level LpA at 3 m	dB(A)	32
Weight	kg	0.78
Ambient air temperature min	°C	1
Ambient air temperature max	°C	40
Ingress protection rating	-	IP45

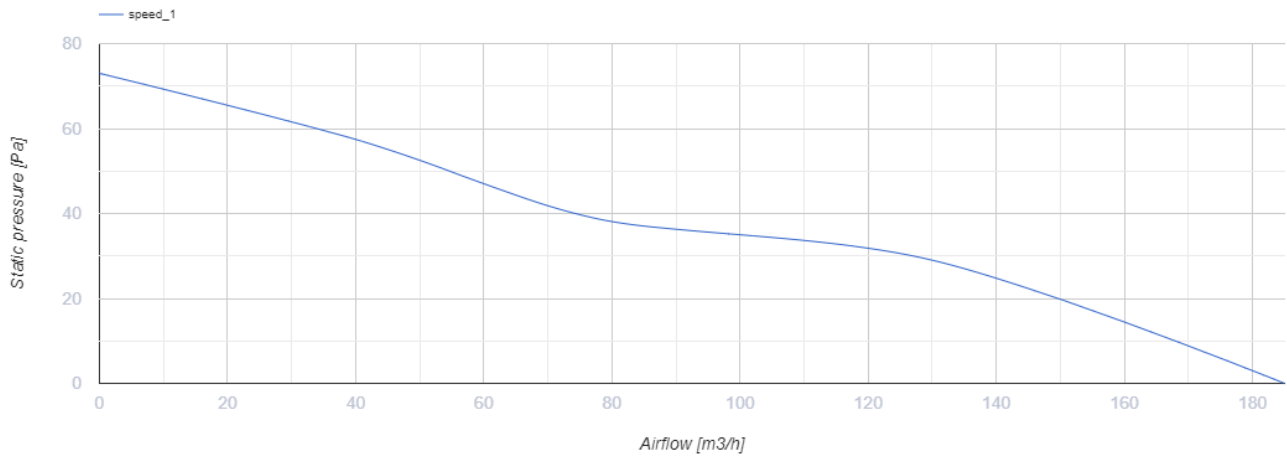

## Dimensions

ØD	B	H	L	L1
123.5	182	158	91	27

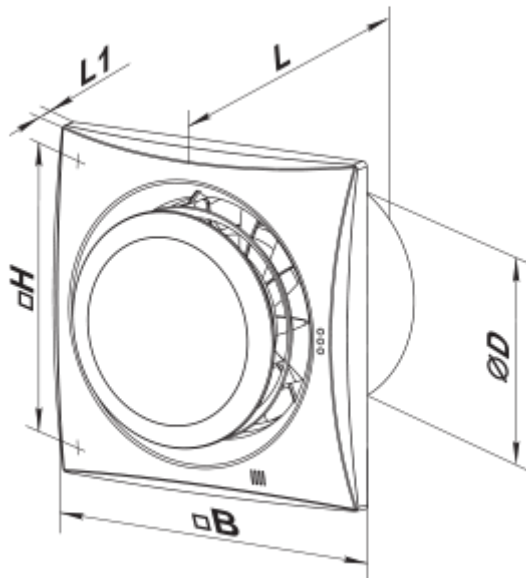

## Accessories

### Cooker Hoods

Name	Photo	Description
<a href="#">FO 125</a>		The window flange applicable for all VENTS fans except for VKO, VKO1, iFan, Quiet, MAO, CF

## Ecodesign

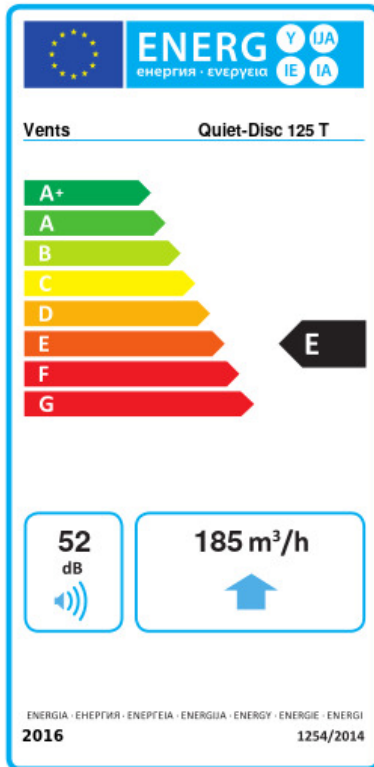

Trademark	Vents					
Model	Quiet-Disc 125 T					
Specific energy consumption (SEC) (kWh/(m <sup>2</sup> /a))	Cold		Average		Warm	
	33.9	B	16	E	5.7	F
Type of ventilation unit	Unidirectional					
Type of drive installed	Single speed					
Type of heat recovery system	None					
Maximum flow rate (m <sup>3</sup> /h)	185					
Electric power input (W)	17					
Reference flow rate (m <sup>3</sup> /s)	0.036					
Specific power input (SPI) (W/(m <sup>3</sup> /h))	0.092					
Control typology	Clock control					
Maximum external leakage rates (%)	2.7					
Sound power level (dB(A))	52					
Declared typology	RVU UVU					
The annual electricity consumption (AEC) (kWh/a)	Cold		Average		Warm	
	109		109		109	
The annual heating saved (AHS) (kWh/a)	Cold		Average		Warm	
	3667		1874		848	