

# Quiet-Mild 125 TP



Axial exhaust fans Quiet-Mild feature low noise and high performance

- Maximum airflow: 185
- Sound pressure level LpA at 3 m: 32
- Motor type: AC
- Casing material: Plastic
- Backdraft protection: Backdraft damper
- Motion sensor
- Timer: Turn off timer

	Unit of measurement	Quiet-Mild 125 TP
Connected air duct size	mm	125
Speed	-	1
Minimum supply voltage	V	220
Maximum supply voltage	V	240
Power supply frequency	Hz	50
Rated power	W	17
Unit current	A	0.11
Maximum airflow	m <sup>3</sup> /h	185
Sound pressure level LpA at 3 m	dB(A)	32
Weight	kg	0.78
Ambient air temperature min	°C	1
Ambient air temperature max	°C	40
Ingress protection rating	-	IP45



### Dimensions

ØD	B	H	L	L1
123.5	182	158	91	27

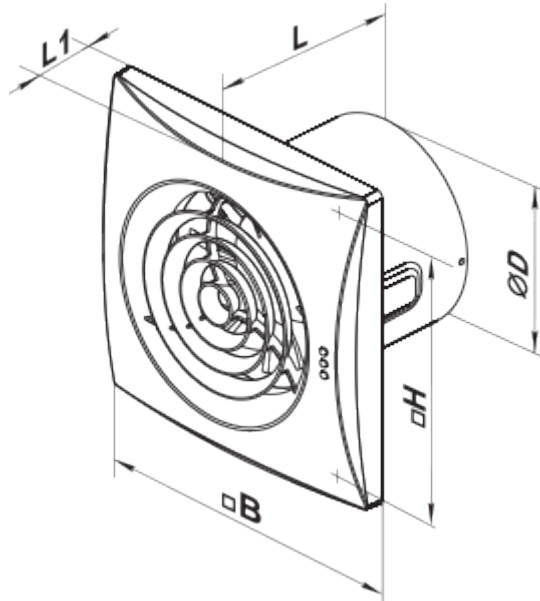

## Accessories

### Flanges

Name	Photo	Description
<a href="#">FO_125</a>		The window flange applicable for all VENTS fans except for VKO, VKO1, iFan, Quiet, MAO, CF

## Ecodesign

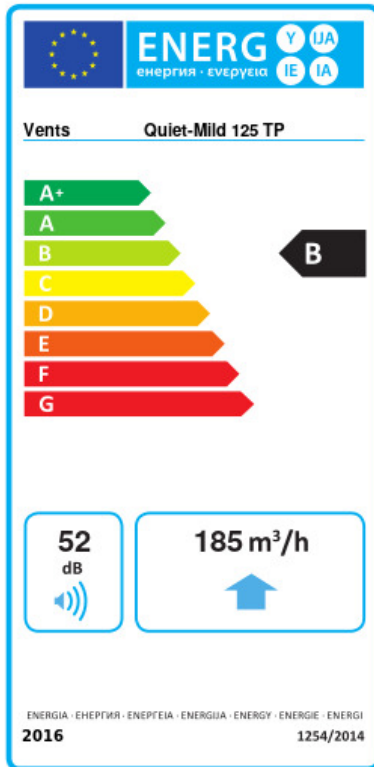

Trademark	Vents					
Model	Quiet-Mild 125 TP					
Specific energy consumption (SEC) (kWh/(m <sup>2</sup> /a))	Cold		Average		Warm	
	-53.5	A+	-26.4	B	-10.9	E
Type of ventilation unit	Unidirectional					
Type of drive installed	Single speed					
Type of heat recovery system	None					
Maximum flow rate (m <sup>3</sup> /h)	185					
Electric power input (W)	17					
Reference flow rate (m <sup>3</sup> /s)	0.036					
Specific power input (SPI) (W/(m <sup>3</sup> /h))	0.092					
Control typology	Local demand control					
Maximum external leakage rates (%)	2.7					
Sound power level (dB(A))	52					
Declared typology	RVU UVU					
The annual electricity consumption (AEC) (kWh/a)	Cold		Average		Warm	
	75		75		75	
The annual heating saved (AHS) (kWh/a)	Cold		Average		Warm	
	5536		2830		1280	