

Quiet-Style 100



Intellectual axial low-noise and energy saving fan for exhaust ventilation

- Maximum airflow: 90
- Sound pressure level LpA at 3 m: 26
- Motor type: AC
- Casing material: Plastic
- Backdraft protection: Backdraft damper

	Unit of measurement	Quiet-Style 100
Connected air duct size	mm	100
Speed	-	1
Minimum supply voltage	V	220
Maximum supply voltage	V	240
Power supply frequency	Hz	50
Rated power	W	7.5
Unit current	A	0.05
Maximum airflow	m ³ /h	90
Sound pressure level LpA at 3 m	dB(A)	26
Weight	kg	0.66
Ambient air temperature min	°C	1
Ambient air temperature max	°C	40
Ingress protection rating	-	IP45

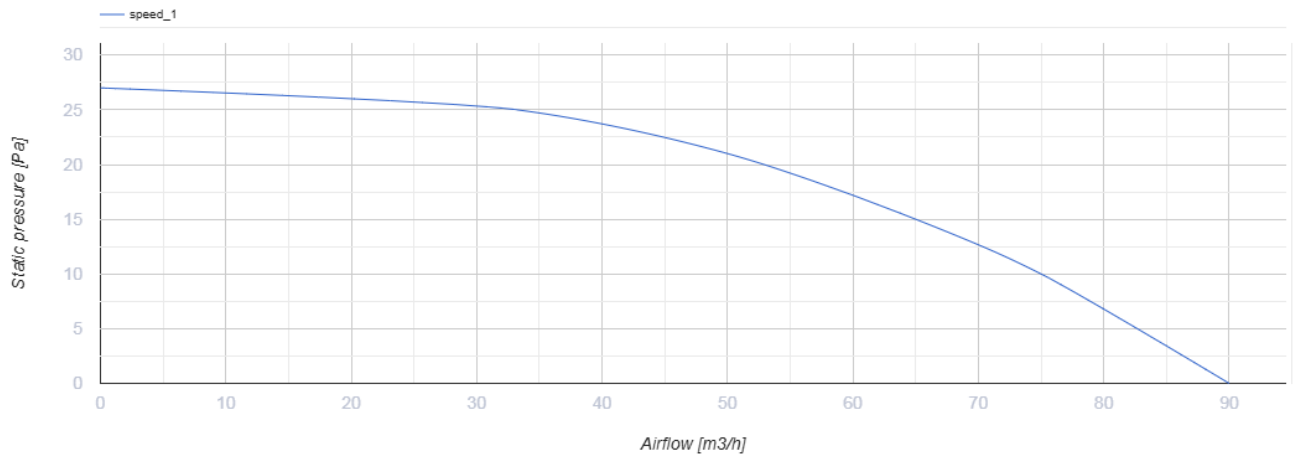

Dimensions

ØD	B	L	L1
99	200	130	49

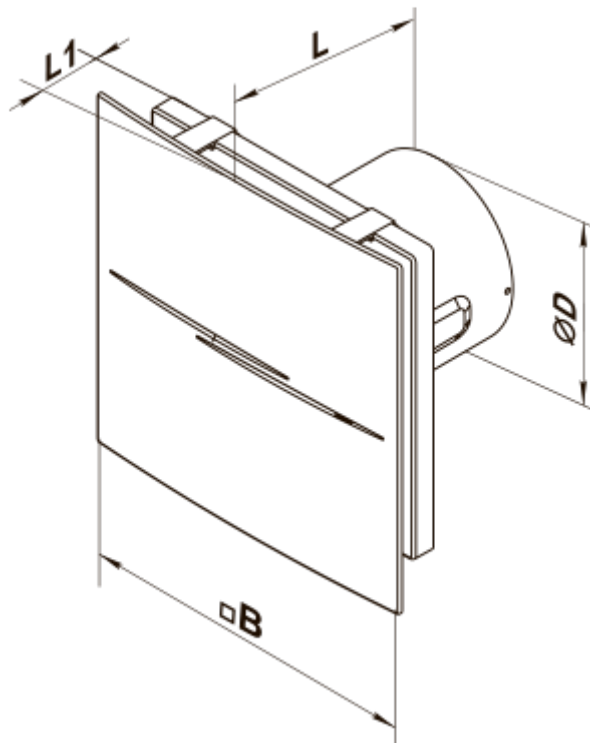

Accessories

Flanges

Name	Photo	Description
------	-------	-------------

[FO_100](#)



The window flange applicable for all VENTS fans except for VKO, VKO1, iFan, Quiet, MAO, CF

Ecodesign

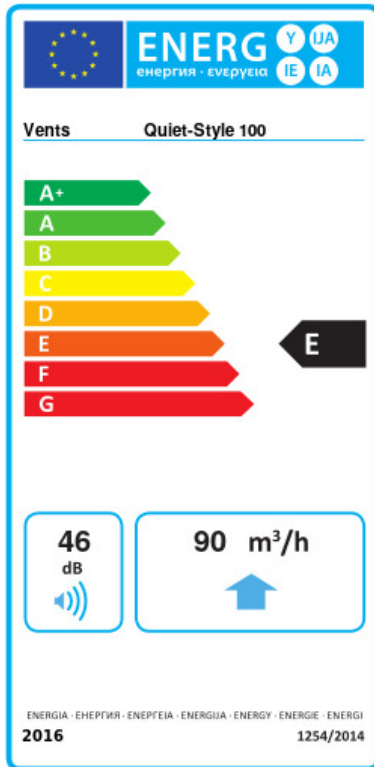

Trademark	Vents					
Model	Quiet-Style 100					
Specific energy consumption (SEC) (kWh/(m²/a))	Cold		Average		Warm	
	-30.9	B	-14.5	E	-5.1	F
Type of ventilation unit	Unidirectional					
Type of drive installed	Single speed					
Type of heat recovery system	None					
Maximum flow rate (m³/h)	90					
Electric power input (W)	7.5					
Reference flow rate (m³/s)	0.018					
Specific power input (SPI) (W/(m³/h))	0.083					
Control typology	Manual control					
Maximum external leakage rates (%)	2.7					
Sound power level (dB(A))	46					
Declared typology	RVU UVU					
The annual electricity consumption (AEC) (kWh/a)	Cold		Average		Warm	
	104		104		104	
The annual heating saved (AHS) (kWh/a)	Cold		Average		Warm	
	3355		1715		776	