

# TT 125 S



## Inline mixed-flow fans

- Maximum airflow: 440
- Sound pressure level LpA at 3 m: 42
- Motor type: AC
- Impeller type: Mixed-flow
- Casing material: Plastic
- Installation in any position

	Unit of measurement	TT 125 S	
Connected air duct size	mm	125	
Speed	-	2	
Minimum supply voltage	V	230	
Maximum supply voltage	V	230	
Power supply frequency	Hz	50/60	
Rated power	W	47	60
Unit current	A	0.21	0.27
Maximum airflow	m <sup>3</sup> /h	295	440
Sound pressure level LpA at 3 m	dB(A)	31	42
Weight	kg	3.14	
Transported air temperature (max)	°C	60	
Transported air temperature (min)	°C	-25	
Ingress protection rating	-	IPX4	
Ingress protection rating of the drive	-	IPX4	

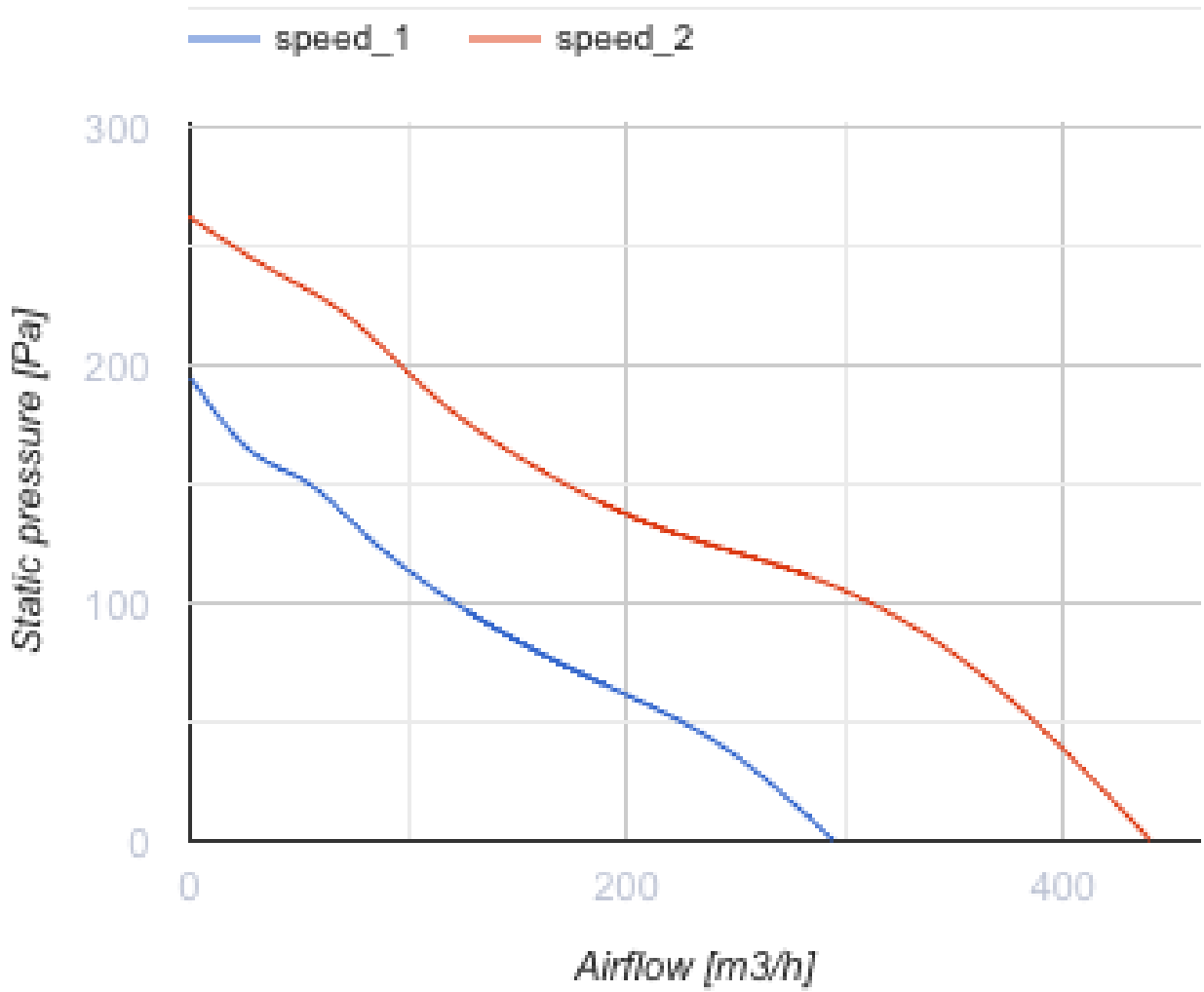

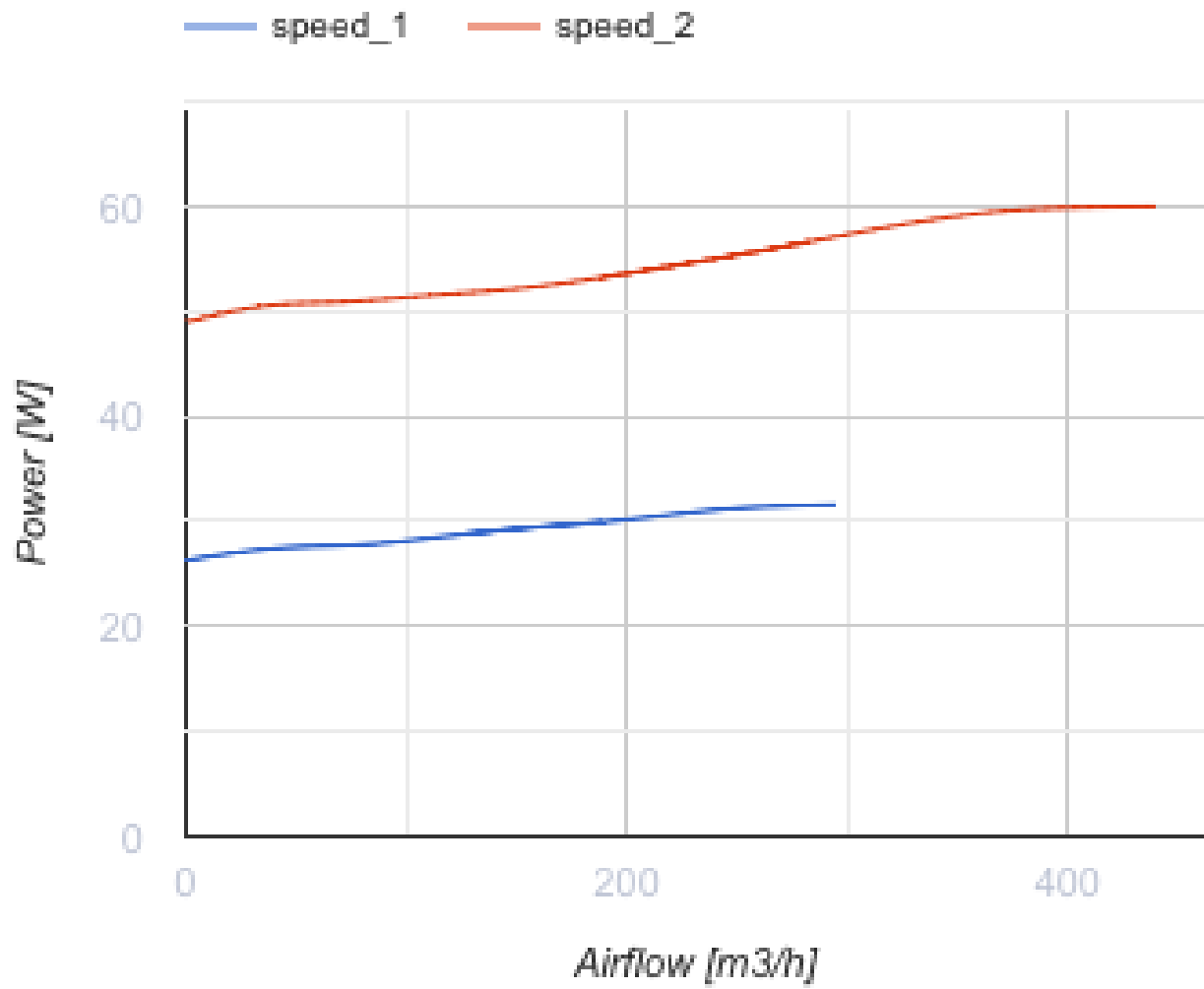

### Dimensions

ØD	B	H	L
123	167	190	246

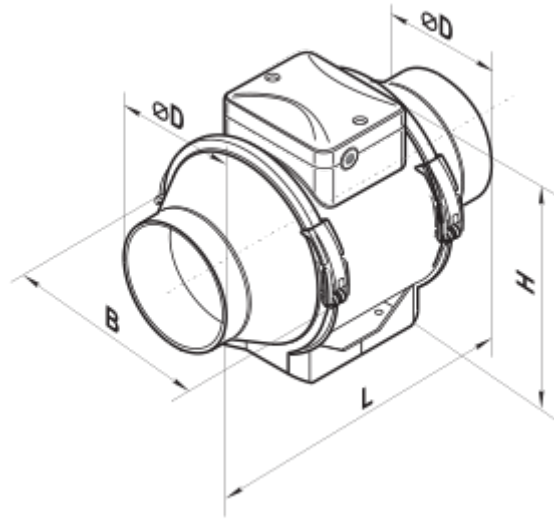

## Ecodesign

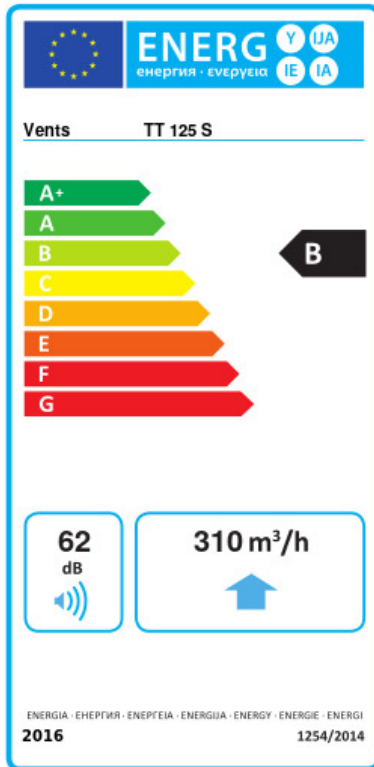

Trademark	Vents					
Model	TT 125 S					
Specific energy consumption (SEC) (kWh/(m <sup>2</sup> /a))	Cold		Average		Warm	
	-53.6	A+	-26.5	B	-11	E
Type of ventilation unit	Unidirectional					
Type of drive installed	Variable speed					
Type of heat recovery system	None					
Maximum flow rate (m <sup>3</sup> /h)	310					
Electric power input (W)	56					
Reference flow rate (m <sup>3</sup> /s)	0.071					
Reference pressure difference (Pa)	50					
Specific power input (SPI) (W/(m <sup>3</sup> /h))	0.134					
Control typology	Local demand control					
Maximum external leakage rates (%)	2.7					
Declared typology	RVU UVU					
Sound power level (dB(A))	62					
The annual electricity consumption (AEC) (kWh/a)	Cold		Average		Warm	
	71		71		71	
The annual heating saved (AHS) (kWh/a)	Cold		Average		Warm	
	5536		2830		1280	