

TT PRO 100 EC U



Inline mixed-flow fans

- Maximum airflow: 300
- Sound pressure level LpA at 3 m: 47
- Motor type: EC
- Control: Built-in speed controller
- Impeller type: Mixed-flow
- Casing material: Plastic
- Installation in any position
- Cable with mains plug
- Temperature sensor

	Unit of measurement	TT PRO 100 EC U
Connected air duct size	mm	100
Speed	-	1
Minimum supply voltage	V	230
Maximum supply voltage	V	230
Power supply frequency	Hz	50/60
Rated power	W	30
Unit current	A	0.29
Maximum airflow	m ³ /h	300
Sound pressure level LpA at 3 m	dB(A)	47
Weight	kg	1.75
Transported air temperature (max)	°C	55
Transported air temperature (min)	°C	-25
Ingress protection rating	-	IPX4

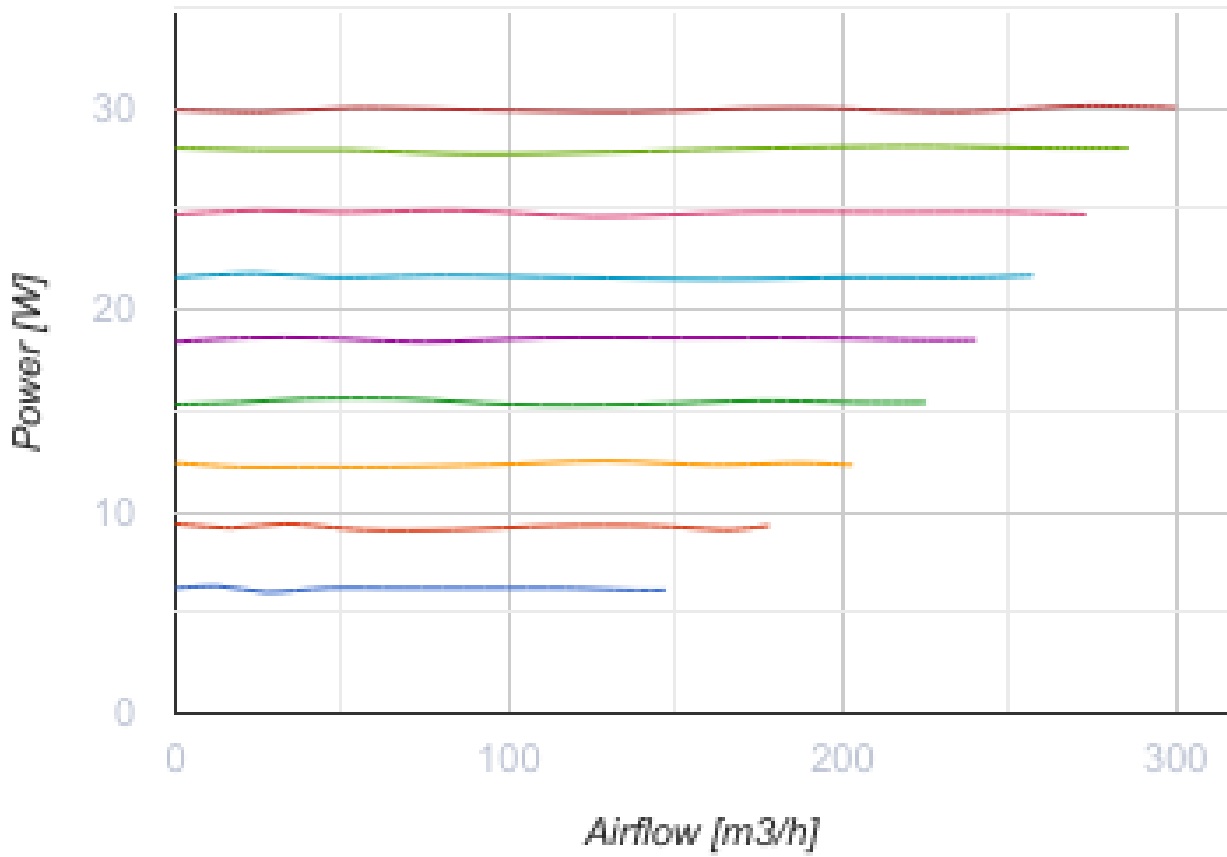

Dimensions

ØD	B	H	L
97	192	241	303

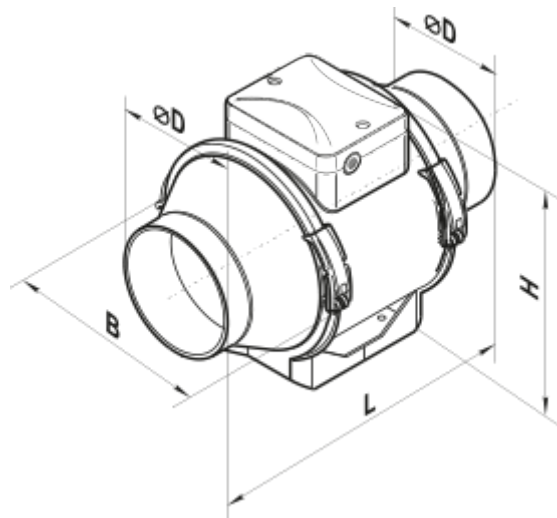

Ecodesign

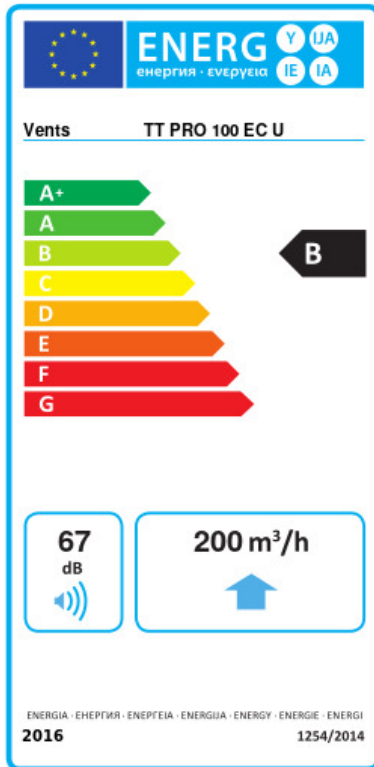

Trademark	Vents					
Model	TT PRO 100 EC U					
Specific energy consumption (SEC) (kWh/(m ² /a))	Cold		Average		Warm	
	-53.9	A+	-26.9	B	-11.4	E
Type of ventilation unit	Unidirectional					
Type of drive installed	Variable speed					
Type of heat recovery system	None					
Maximum flow rate (m ³ /h)	200					
Electric power input (W)	30					
Reference flow rate (m ³ /s)	0.039					
Reference pressure difference (Pa)	50					
Specific power input (SPI) (W/(m ³ /h))	0.109					
Control typology	Local demand control					
Maximum external leakage rates (%)	2.7					
Declared typology	RVU UVU					
Sound power level (dB(A))	67					
The annual electricity consumption (AEC) (kWh/a)	Cold		Average		Warm	
	58		58		58	
The annual heating saved (AHS) (kWh/a)	Cold		Average		Warm	
	5536		2830		1280	