

TT PRO 160 EC P



Inline mixed-flow fans

- Maximum airflow: 600
- Sound pressure level LpA at 3 m: 46
- Motor type: EC
- Control: Built-in speed controller
- Impeller type: Mixed
- Casing material: Plastic
- Installation in any position
- Cable with mains plug

	Unit of measurement	TT PRO 160 EC P
Connected air duct size	mm	160
Speed	-	1
Minimum supply voltage	V	230
Maximum supply voltage	V	230
Power supply frequency	Hz	50/60
Rated power	W	55
Unit current	A	0.48
Maximum airflow	m ³ /h	600
Sound pressure level LpA at 3 m	dB(A)	46
Weight	kg	3.25
Transported air temperature (max)	°C	55
Transported air temperature (min)	°C	-25
Ingress protection rating	-	IPX4

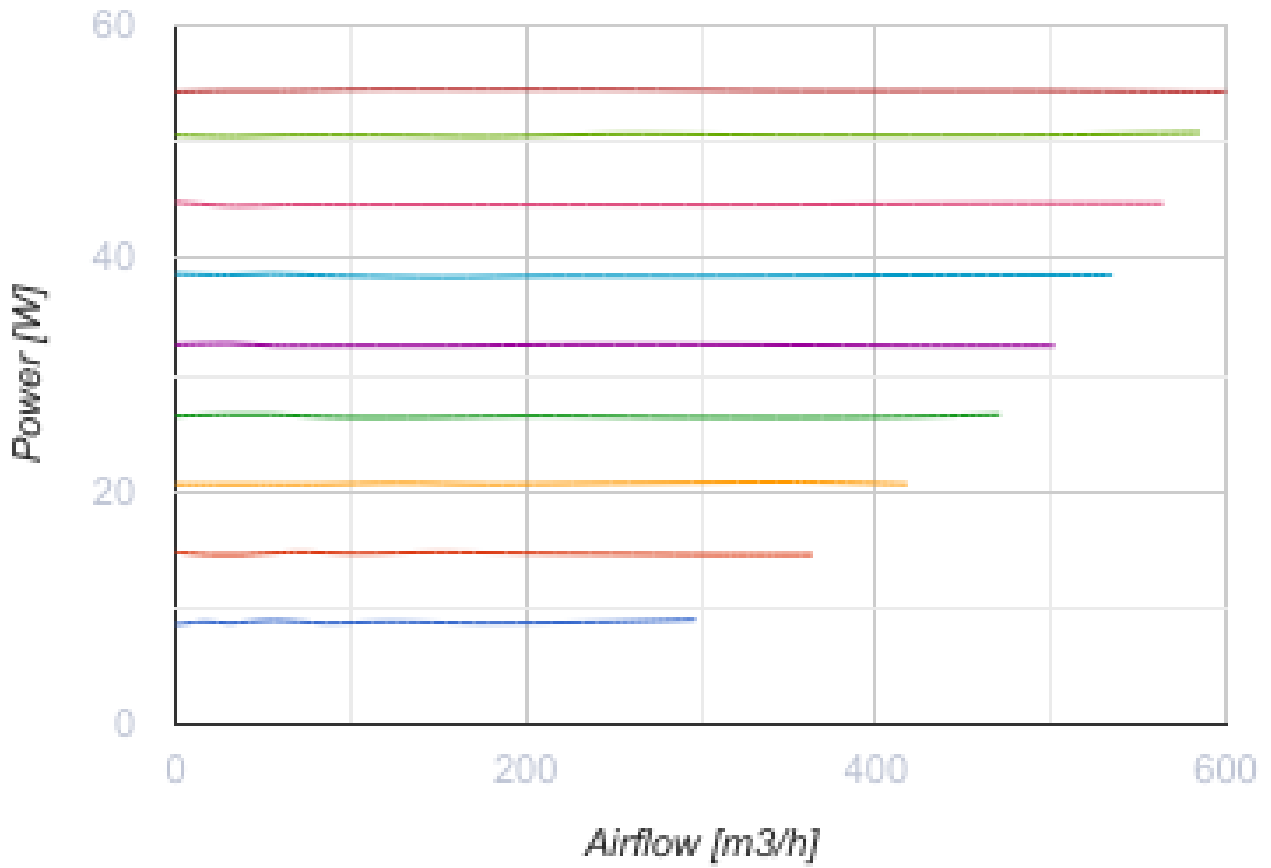

Dimensions

ØD	B	H	L
158	217	289	254

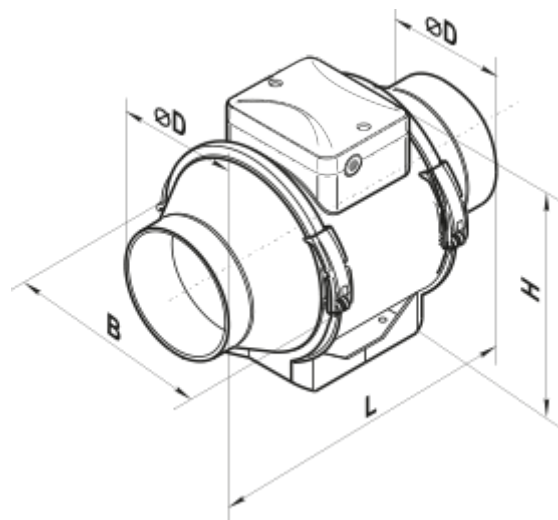

Ecodesign

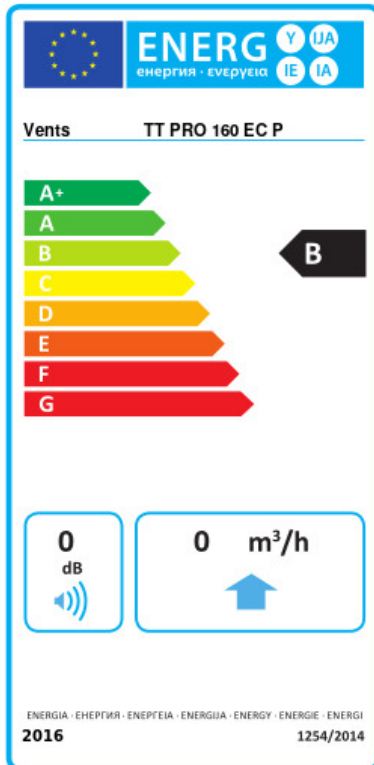

Trademark	Vents					
Model	TT PRO 160 EC P					
Specific energy consumption (SEC) (kWh/(m ² /a))	Cold		Average		Warm	
	0	A+	0	B	0	E
Type of ventilation unit	Unidirectional					
Type of drive installed	Variable speed					
Type of heat recovery system	None					
Maximum flow rate (m ³ /h)	0					
Electric power input (W)	0					
Reference flow rate (m ³ /s)	0					
Reference pressure difference (Pa)	0					
Specific power input (SPI) (W/(m ³ /h))	0					
Control typology	Local demand control					
Maximum external leakage rates (%)	0					
Sound power level (dB(A))	0					
Declared typology	RVU UVU					
The annual electricity consumption (AEC) (kWh/a)	Cold		Average		Warm	
	0		0		0	
The annual heating saved (AHS) (kWh/a)	Cold		Average		Warm	
	0		0		0	