

# TT PRO 160 EC U



Inline mixed-flow fans

- Maximum airflow: 600
- Sound pressure level LpA at 3 m: 46
- Motor type: EC
- Control: Built-in speed controller
- Impeller type: Mixed-flow
- Casing material: Plastic
- Installation in any position
- Cable with mains plug
- Temperature sensor

	Unit of measurement	TT PRO 160 EC U
Connected air duct size	mm	160
Speed	-	1
Minimum supply voltage	V	230
Maximum supply voltage	V	230
Power supply frequency	Hz	50/60
Rated power	W	55
Unit current	A	0.48
Maximum airflow	m <sup>3</sup> /h	600
Sound pressure level LpA at 3 m	dB(A)	46
Weight	kg	3.25
Transported air temperature (max)	°C	55
Transported air temperature (min)	°C	-25
Ingress protection rating	-	IPX4



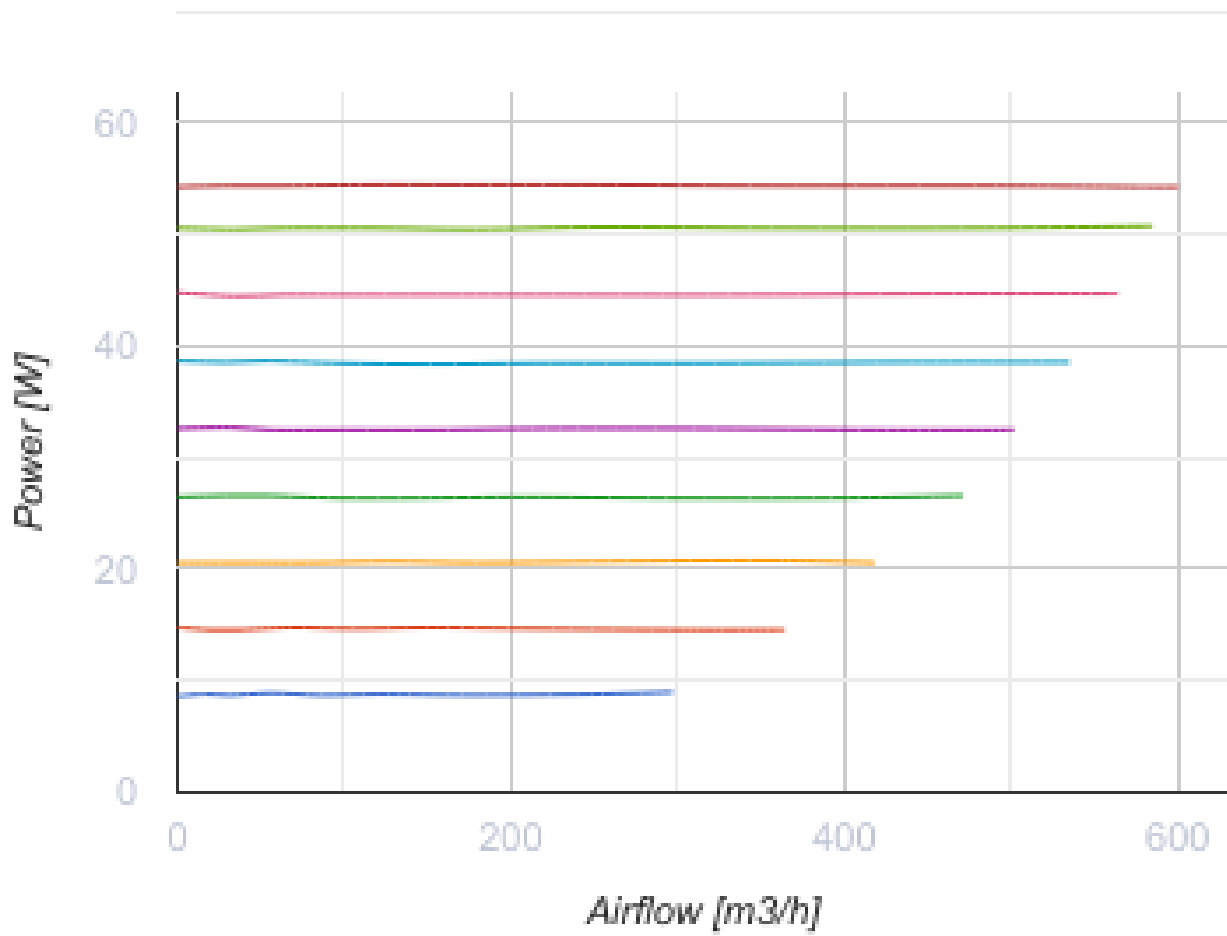

### Dimensions

∅D	B	H	L
158	217	289	254

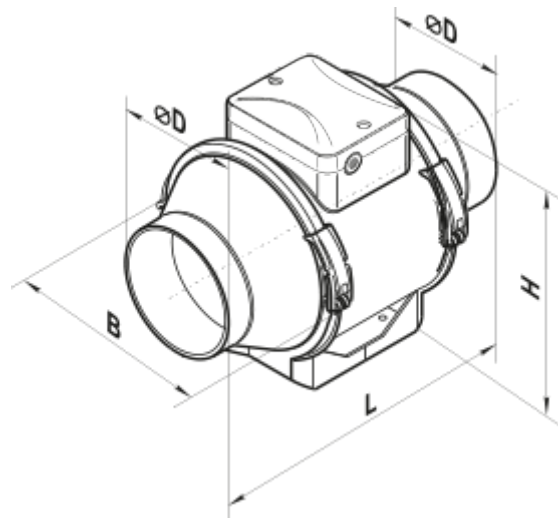

## Ecodesign

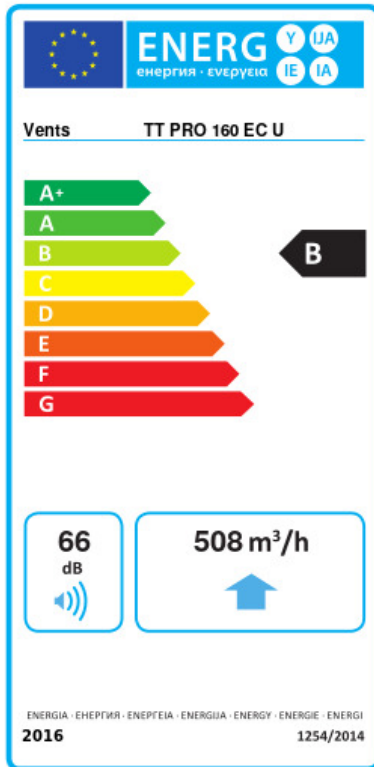

Trademark	Vents					
Model	TT PRO 160 EC U					
Specific energy consumption (SEC) (kWh/(m <sup>2</sup> /a))	Cold		Average		Warm	
	-54.6	A+	-27.5	B	-12	E
Type of ventilation unit	Unidirectional					
Type of drive installed	Variable speed					
Type of heat recovery system	None					
Maximum flow rate (m <sup>3</sup> /h)	508					
Electric power input (W)	54.3					
Reference flow rate (m <sup>3</sup> /s)	0.099					
Reference pressure difference (Pa)	50					
Specific power input (SPI) (W/(m <sup>3</sup> /h))	0.058					
Control typology	Local demand control					
Maximum external leakage rates (%)	2.7					
Declared typology	RVU UVU					
Sound power level (dB(A))	66					
The annual electricity consumption (AEC) (kWh/a)	Cold		Average		Warm	
	31		31		31	
The annual heating saved (AHS) (kWh/a)	Cold		Average		Warm	
	5536		2830		1280	