

TT PRO 200 EC



Inline mixed-flow fans

- Maximum airflow: 1040
- Sound pressure level LpA at 3 m: 49
- Motor type: EC
- Impeller type: Mixed-flow
- Casing material: Plastic
- Installation in any position

	Unit of measurement	TT PRO 200 EC
Connected air duct size	mm	200
Speed	-	1
Minimum supply voltage	V	230
Maximum supply voltage	V	230
Power supply frequency	Hz	50/60
Rated power	W	123
Unit current	A	1.02
Maximum airflow	m ³ /h	1040
Sound pressure level LpA at 3 m	dB(A)	49
Weight	kg	3.95
Transported air temperature (max)	°C	55
Transported air temperature (min)	°C	-25
Ingress protection rating	-	IPX4

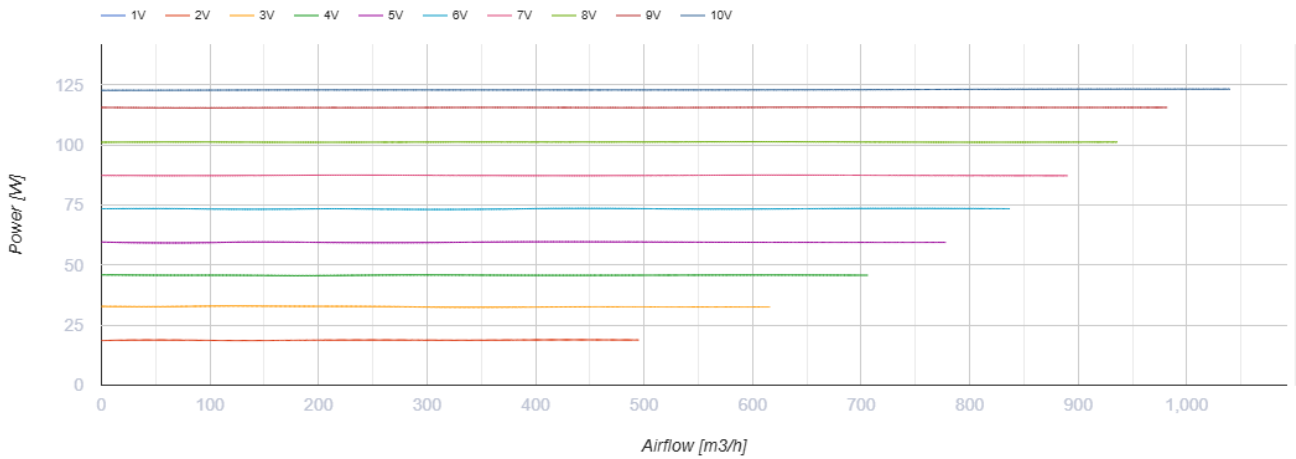
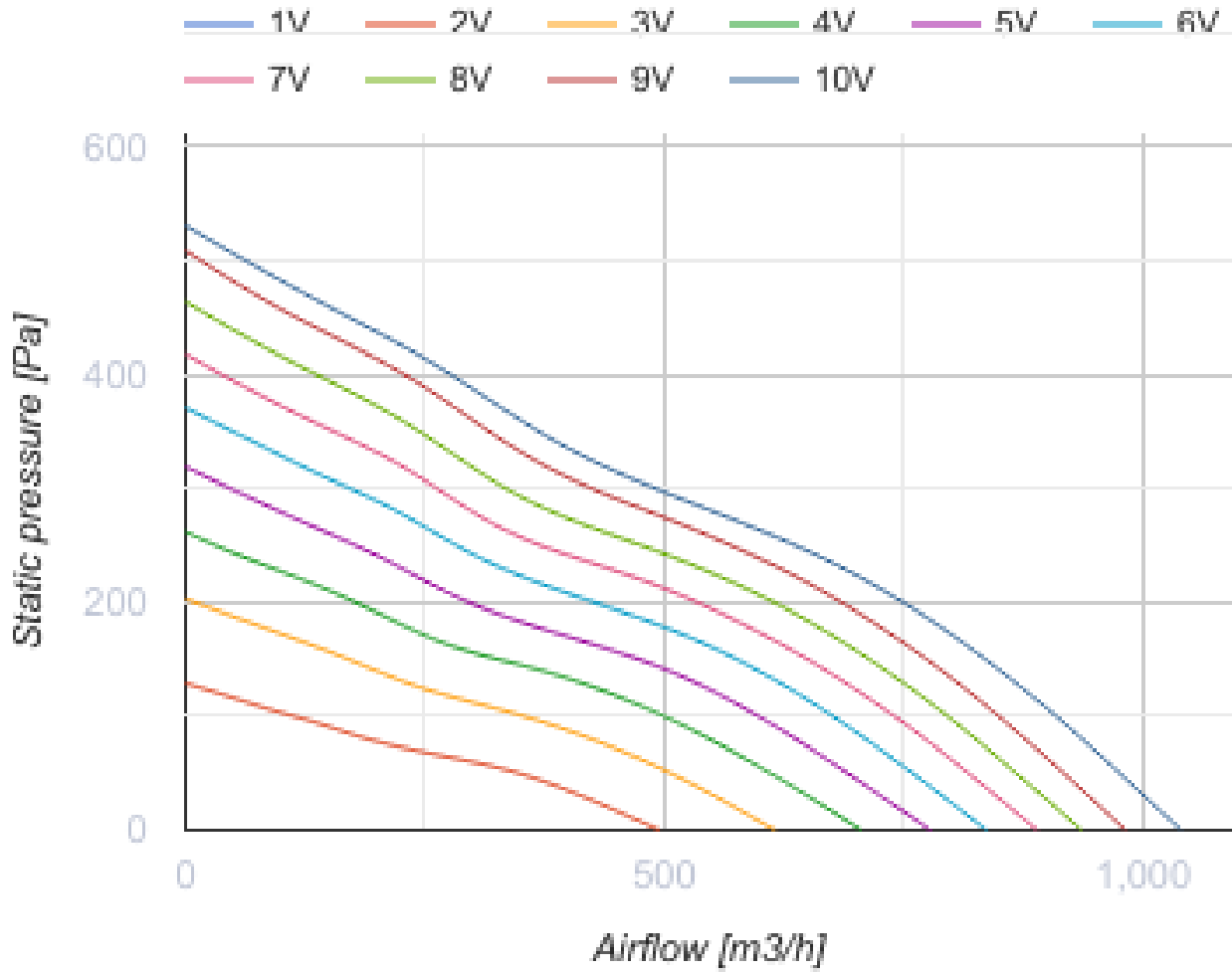

Dimensions

ØD	B	H	L
197	239	296	278

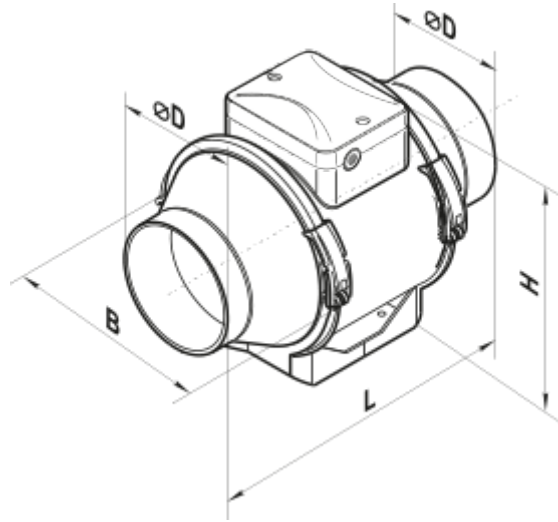

Ecodesign

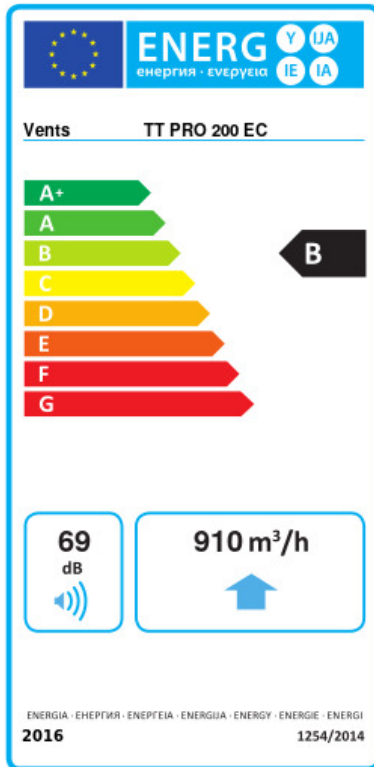

Trademark	Vents					
Model	TT PRO 200 EC					
Specific energy consumption (SEC) (kWh/(m ² /a))	Cold		Average		Warm	
	-54.1	A+	-27.1	B	-11.6	E
Type of ventilation unit	Unidirectional					
Type of drive installed	Variable speed					
Type of heat recovery system	None					
Maximum flow rate (m ³ /h)	910					
Electric power input (W)	123					
Reference flow rate (m ³ /s)	0.177					
Reference pressure difference (Pa)	50					
Specific power input (SPI) (W/(m ³ /h))	0.094					
Control typology	Local demand control					
Maximum external leakage rates (%)	2.7					
Declared typology	RVU UVU					
Sound power level (dB(A))	69					
The annual electricity consumption (AEC) (kWh/a)	Cold		Average		Warm	
	50		50		50	
The annual heating saved (AHS) (kWh/a)	Cold		Average		Warm	
	5536		2830		1280	