

TT PRO 250 EC



Mixed-flow inline fans with EC-motors

- Maximum airflow: 1285
- Sound pressure level LpA at 3 m: 53
- Motor type: EC
- Impeller type: Mixed-flow
- Casing material: Plastic
- Installation in any position

	Unit of measurement	TT PRO 250 EC
Connected air duct size	mm	250
Speed	-	1
Minimum supply voltage	V	230
Maximum supply voltage	V	230
Power supply frequency	Hz	50/60
Rated power	W	169
Unit current	A	1.38
Maximum airflow	m ³ /h	1285
Sound pressure level LpA at 3 m	dB(A)	53
Weight	kg	7.8
Transported air temperature (max)	°C	55
Transported air temperature (min)	°C	-25
Ingress protection rating	-	IPX4

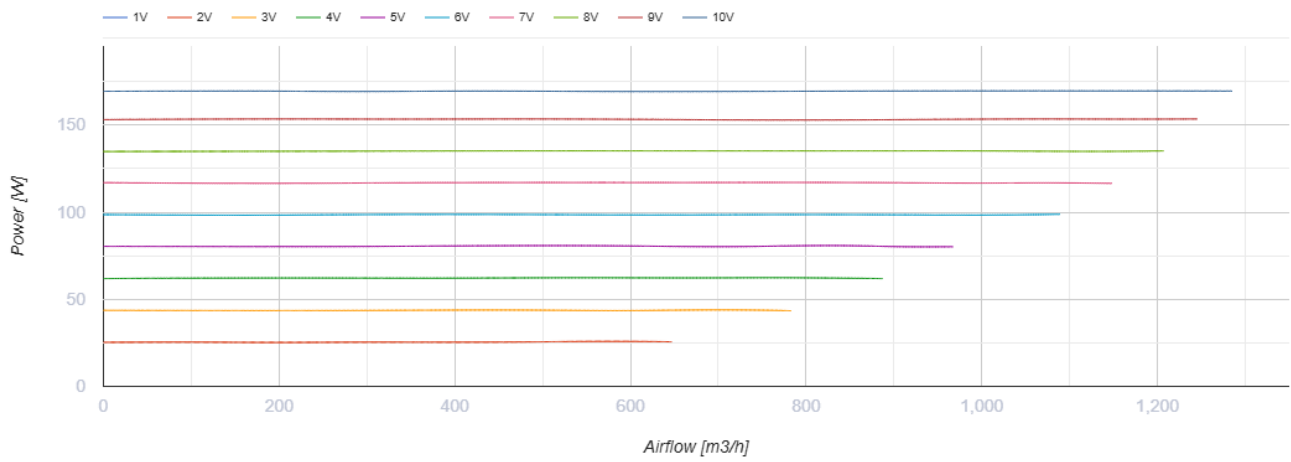
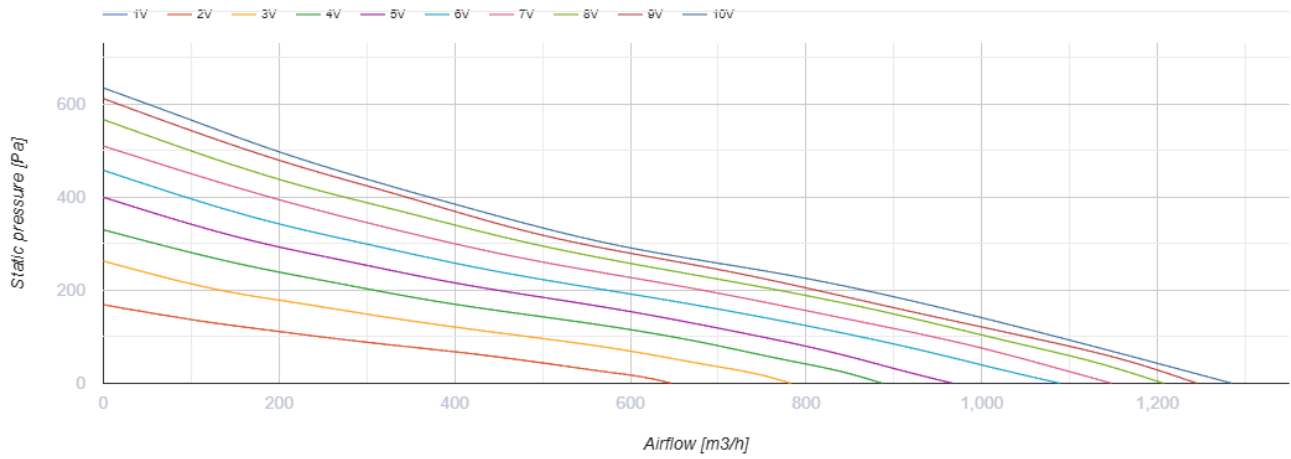

Dimensions

ØD	B	H	L
247	288	339	383

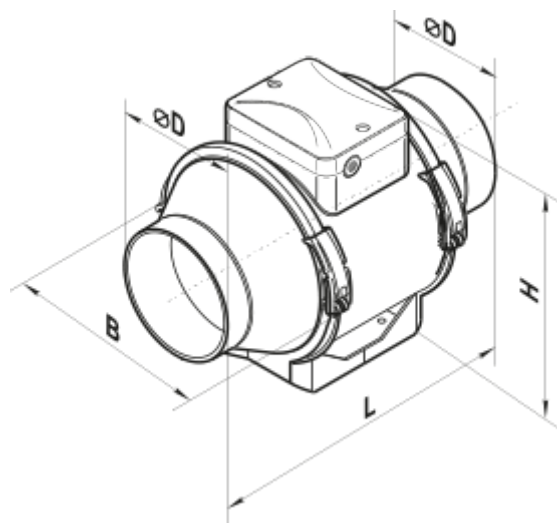

Ecodesign

Trademark	Vents
Model	TT PRO 250 EC
Type of drive installed	Integrated VSD
Type of heat recovery system	None
Nominal flow rate (m ³ /s)	0.216
Nominal external pressure (Pa)	234
Maximum external leakage rates (%)	2.7
Static efficiency (%)	34.8
Declared typology	NRVU UVU
Sound power level (dB(A))	73
Effective electric power input (kW)	0.169