

TT Silent-M 125



Inline mixed-flow fans in sound- and heat-insulated casing

- Maximum airflow: 340
- Sound pressure level LpA at 3 m: 28
- Sound insulation
- Motor type: AC
- Impeller type: Mixed-flow
- Casing material: Coated steel
- Installation in any position

	Unit of measurement	TT Silent-M 125	
Connected air duct size	mm	125	
Speed	-	2	
Minimum supply voltage	V	230	
Maximum supply voltage	V	230	
Power supply frequency	Hz	50/60	
Rated power	W	25	29
Unit current	A	0.11	0.13
Maximum airflow	m ³ /h	230	340
Sound pressure level LpA at 3 m	dB(A)	23	28
Weight	kg	4.6	
Transported air temperature (max)	°C	60	
Ingress protection rating	-	IPX4	
Ingress protection rating of the drive	-	IPX4	

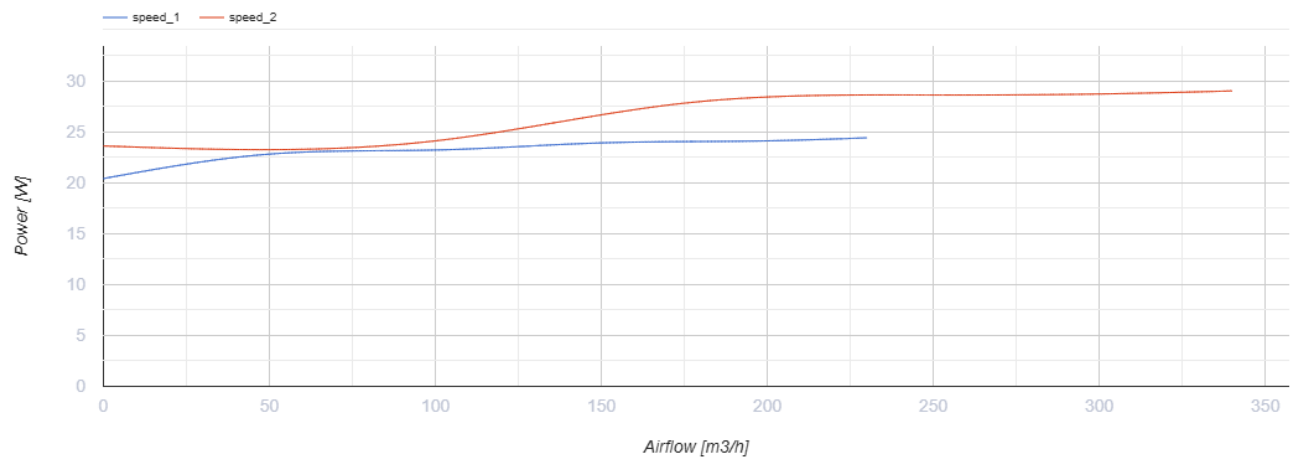
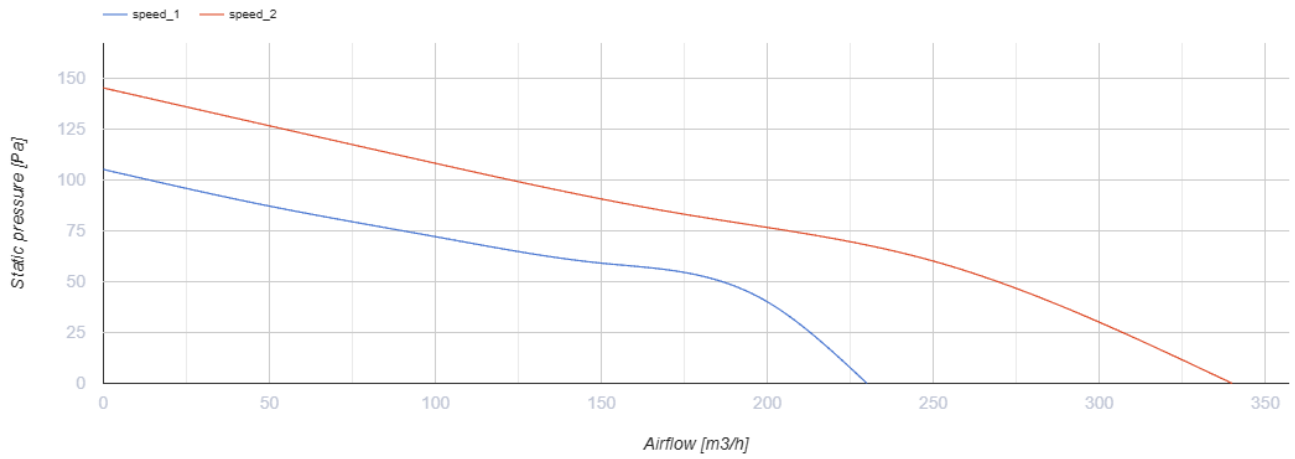

Dimensions

ØD	B	B1	L	H
123	215	243	474	237

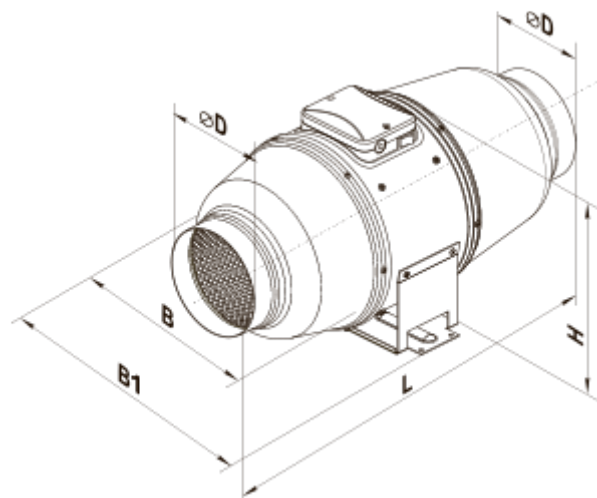

Ecodesign

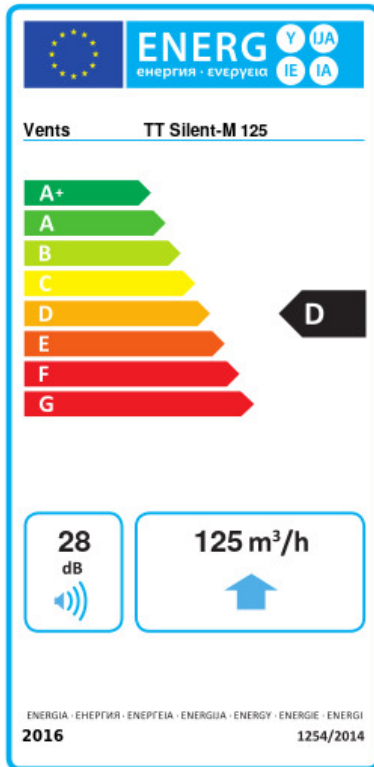

Trademark	Vents					
Model	TT Silent-M 125					
Specific energy consumption (SEC) (kWh/(m ² /a))	Cold		Average		Warm	
	-50	A+	-23	D	-7.5	F
Type of ventilation unit	Unidirectional					
Type of drive installed	Multi-speed					
Type of heat recovery system	None					
Maximum flow rate (m ³ /h)	125					
Electric power input (W)	29					
Reference flow rate (m ³ /s)	0.024					
Reference pressure difference (Pa)	50					
Specific power input (SPI) (W/(m ³ /h))	0.286					
Control typology	Local demand control					
Maximum external leakage rates (%)	2.7					
Declared typology	RVU UVU					
Sound power level (dB(A))	28					
The annual electricity consumption (AEC) (kWh/a)	Cold		Average		Warm	
	213		213		213	
The annual heating saved (AHS) (kWh/a)	Cold		Average		Warm	
	5536		2830		1280	