

# VCN 125 EC



Exhaust centrifugal fans in steel casing for outdoor surface mounting

- Maximum airflow: 480
- Sound pressure level LpA at 3 m: 57
- Motor type: EC
- Impeller type: Centrifugal backward curved blades
- Casing material: Coated steel
- Installation in any position

	Unit of measurement	VCN 125 EC
Connected air duct size	mm	125
Speed	-	1
Minimum supply voltage	V	230
Maximum supply voltage	V	230
Power supply frequency	Hz	50/60
Rated power	W	103
Unit current	A	0.83
Maximum airflow	m <sup>3</sup> /h	480
Sound pressure level LpA at 3 m	dB(A)	57
Weight	kg	3.6
Transported air temperature (max)	°C	40
Transported air temperature (min)	°C	-25
Ingress protection rating	-	IPX4
Ingress protection rating of the drive	-	IP55

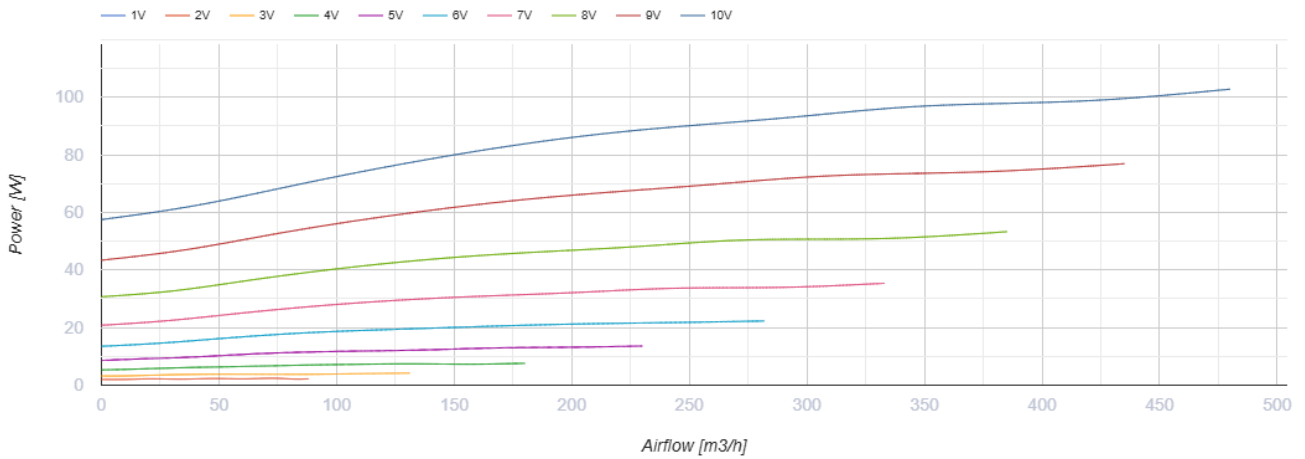
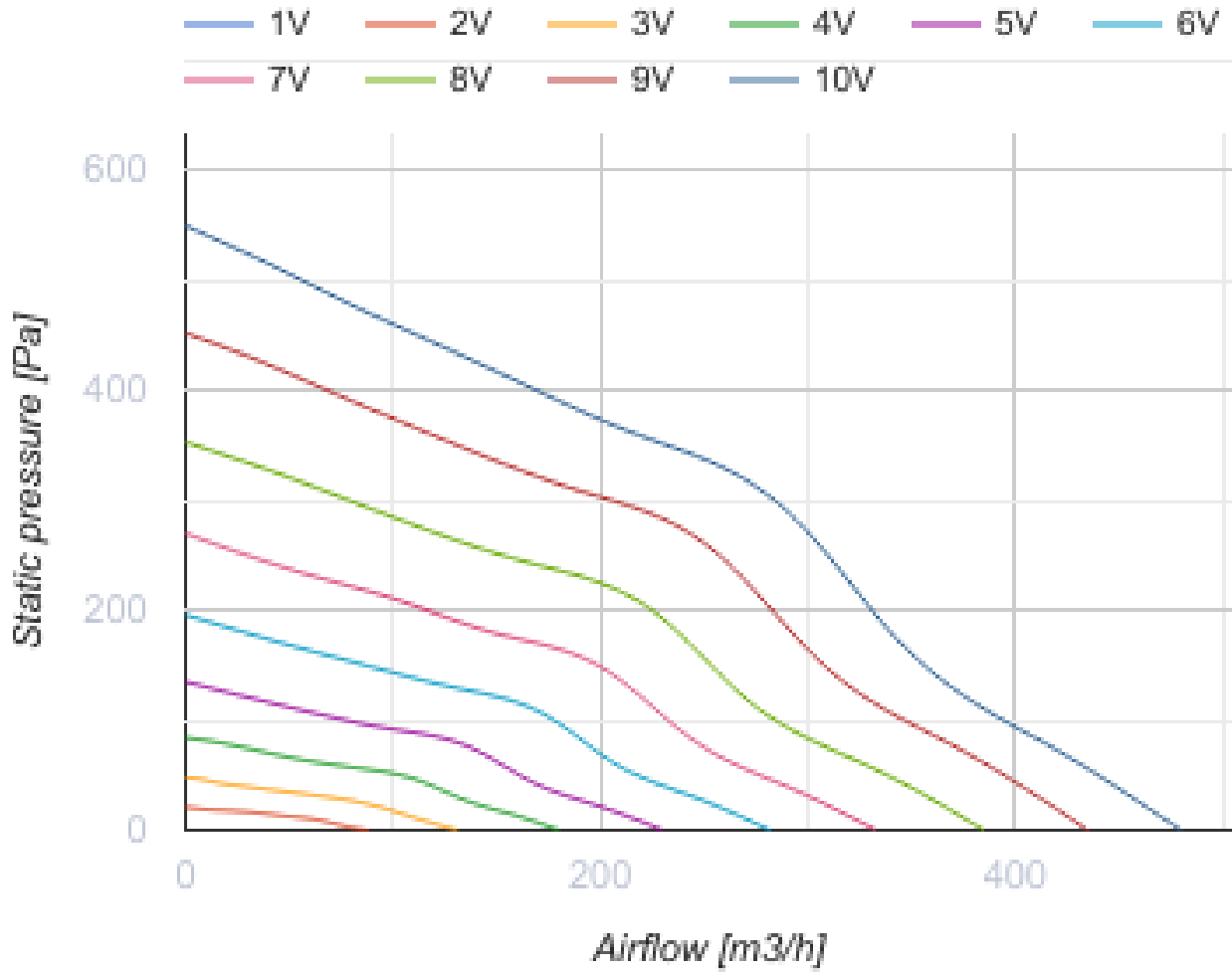

## Dimensions

ØD	L	B	H
125	355	260	140

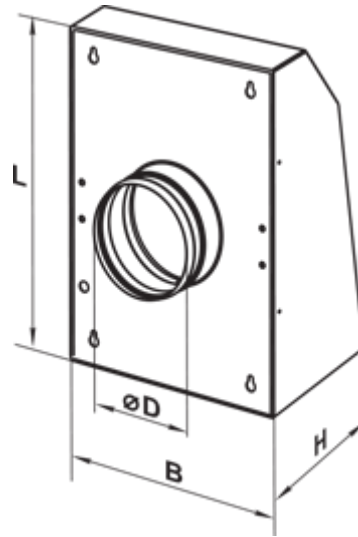

## Ecodesign

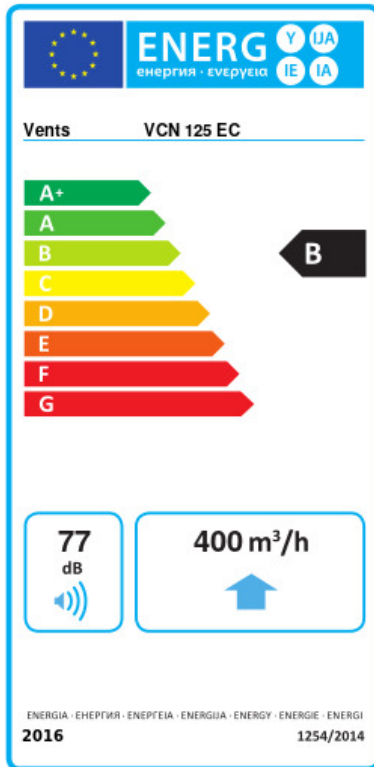

Trademark	Vents					
Model	VCN 125 EC					
Specific energy consumption (SEC) (kWh/(m <sup>2</sup> /a))	Cold		Average		Warm	
	-53.8	A+	-26.7	B	-11.2	E
Type of ventilation unit	Unidirectional					
Type of drive installed	Variable speed					
Type of heat recovery system	None					
Maximum flow rate (m <sup>3</sup> /h)	400					
Electric power input (W)	98					
Reference flow rate (m <sup>3</sup> /s)	0.078					
Reference pressure difference (Pa)	50					
Specific power input (SPI) (W/(m <sup>3</sup> /h))	0.121					
Control typology	Local demand control					
Maximum external leakage rates (%)	2.7					
Declared typology	RVU UVU					
Sound power level (dB(A))	77					
The annual electricity consumption (AEC) (kWh/a)	Cold		Average		Warm	
	64		64		64	
The annual heating saved (AHS) (kWh/a)	Cold		Average		Warm	
	5536		2830		1280	