

VKM 125



Inline centrifugal fans in steel casing

- Maximum airflow: 360
- Sound pressure level LpA at 3 m: 40
- Motor type: AC
- Impeller type: Centrifugal backward curved blades
- Casing material: Coated steel
- Installation in any position

	Unit of measurement	VKM 125
Connected air duct size	mm	125
Speed	-	1
Minimum supply voltage	V	220
Maximum supply voltage	V	240
Power supply frequency	Hz	50/60
Rated power	W	64
Unit current	A	0.29
Maximum airflow	m ³ /h	360
Sound pressure level LpA at 3 m	dB(A)	40
Weight	kg	3.2
Transported air temperature (max)	°C	45
Transported air temperature (min)	°C	-25
Ingress protection rating	-	IPX4
Ingress protection rating of the drive	-	IP44

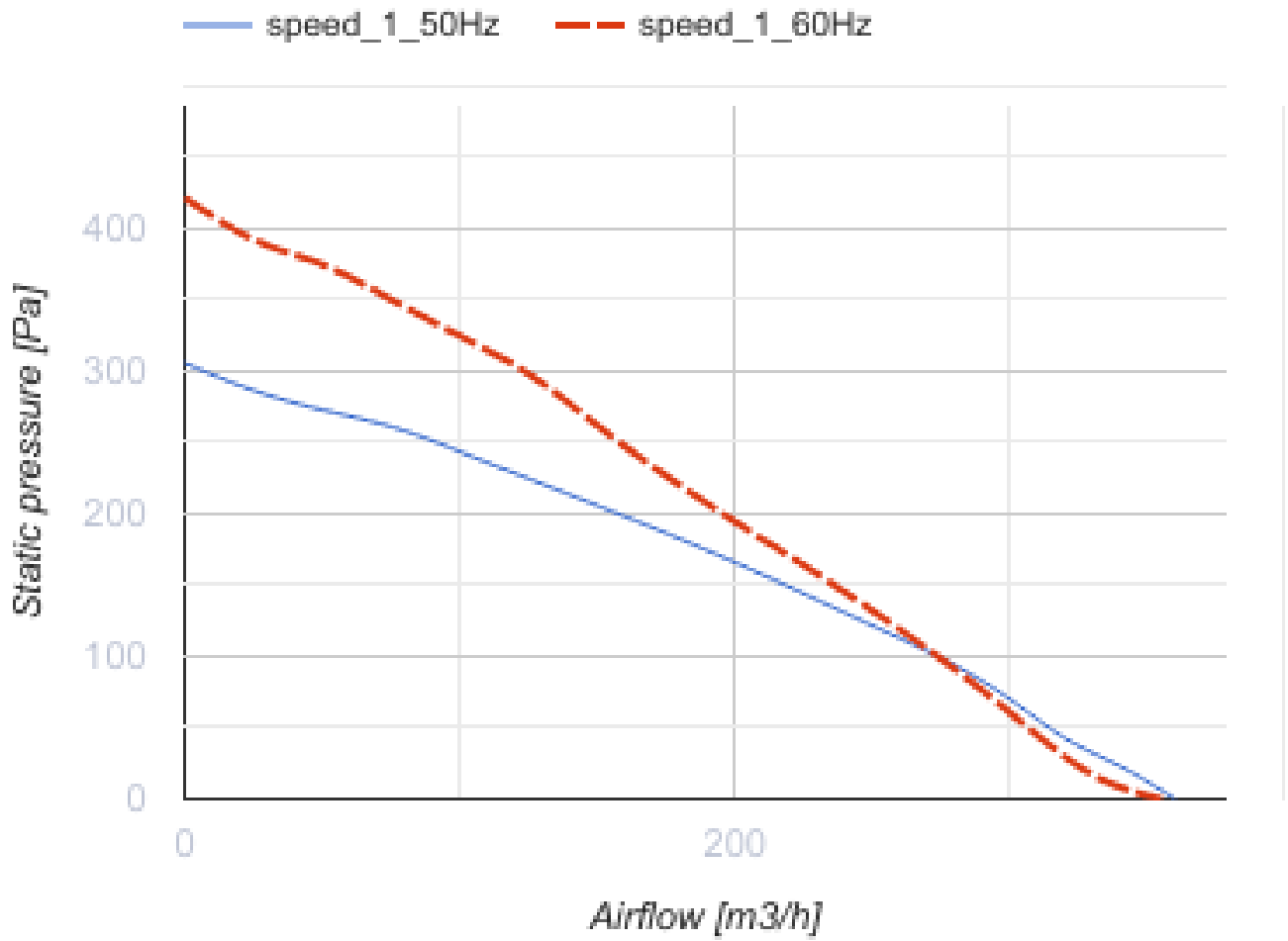

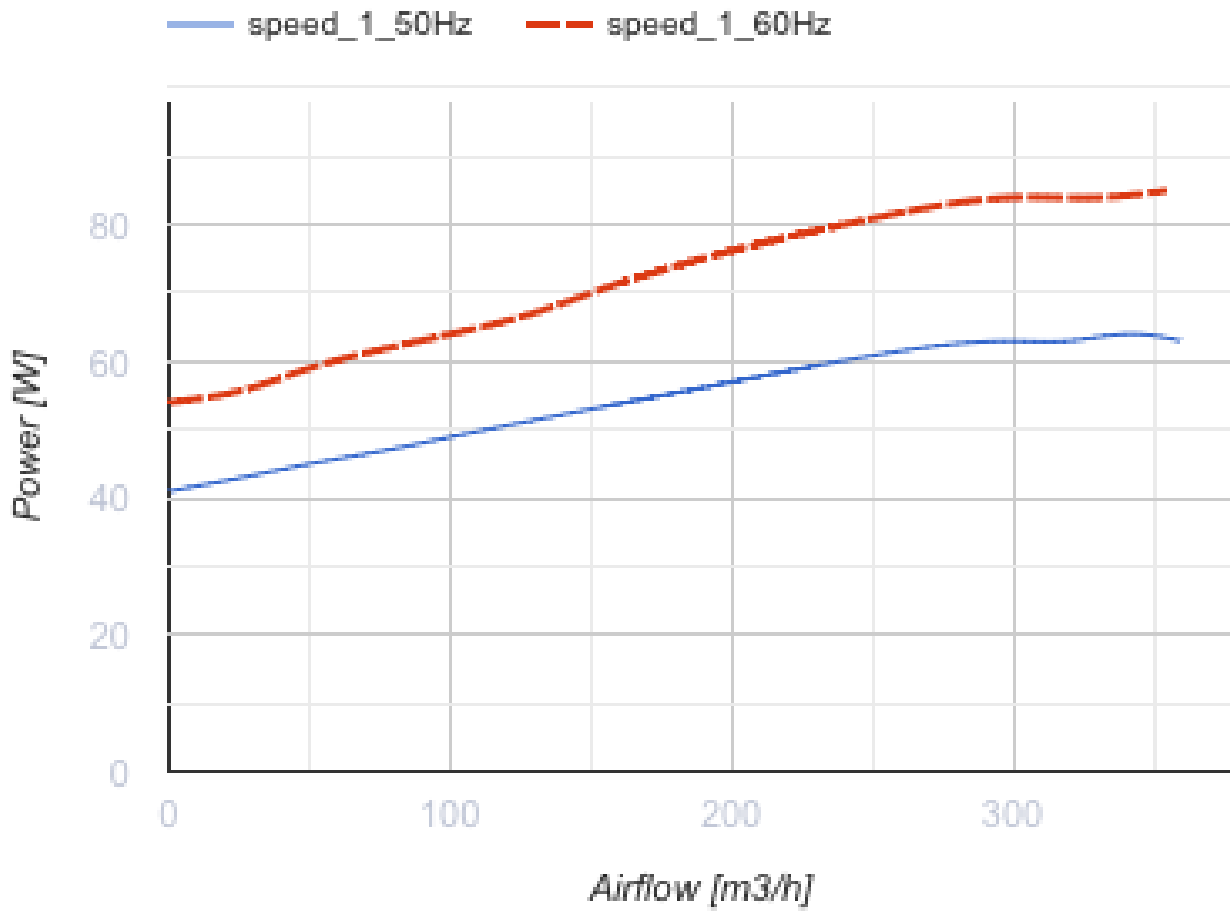

Dimensions

ØD	ØD1	B	B1	L	L1	L2	L3
123	255	310	270	205	20	25	30

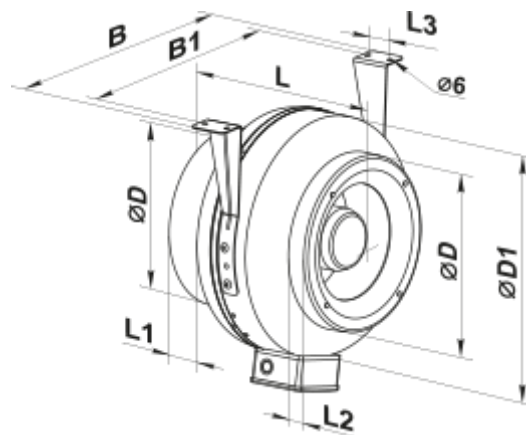

Ecodesign

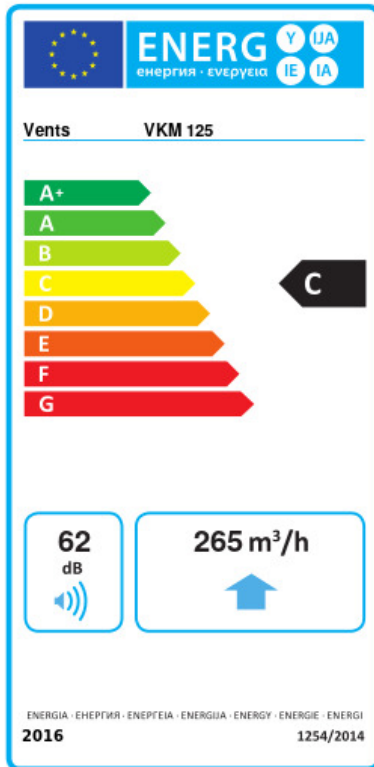

Trademark	Vents					
Model	VKM 125					
Specific energy consumption (SEC) (kWh/(m ² /a))	Cold		Average		Warm	
	-51.5	A+	-24.4	C	-8.9	F
Type of ventilation unit	Unidirectional					
Type of drive installed	Variable speed					
Type of heat recovery system	None					
Maximum flow rate (m ³ /h)	265					
Electric power input (W)	62					
Reference flow rate (m ³ /s)	0.052					
Reference pressure difference (Pa)	50					
Specific power input (SPI) (W/(m ³ /h))	0.291					
Control typology	Local demand control					
Maximum external leakage rates (%)	2.7					
Declared typology	RVU UVU					
Sound power level (dB(A))	62					
The annual electricity consumption (AEC) (kWh/a)	Cold		Average		Warm	
	154		154		154	
The annual heating saved (AHS) (kWh/a)	Cold		Average		Warm	
	5536		2830		1280	