

# VKMS 160



Inline centrifugal fans in steel casing

- Maximum airflow: 690
- Sound pressure level LpA at 3 m: 48
- Motor type: AC
- Impeller type: Centrifugal backward curved blades
- Casing material: Coated steel
- Installation in any position

	Unit of measurement	VKMS 160
Connected air duct size	mm	160
Speed	-	1
Minimum supply voltage	V	220
Maximum supply voltage	V	240
Power supply frequency	Hz	50/60
Rated power	W	121
Unit current	A	0.53
Maximum airflow	m <sup>3</sup> /h	690
Sound pressure level LpA at 3 m	dB(A)	48
Weight	kg	6.4
Transported air temperature (max)	°C	45
Transported air temperature (min)	°C	-25
Ingress protection rating	-	IPX4
Ingress protection rating of the drive	-	IP44

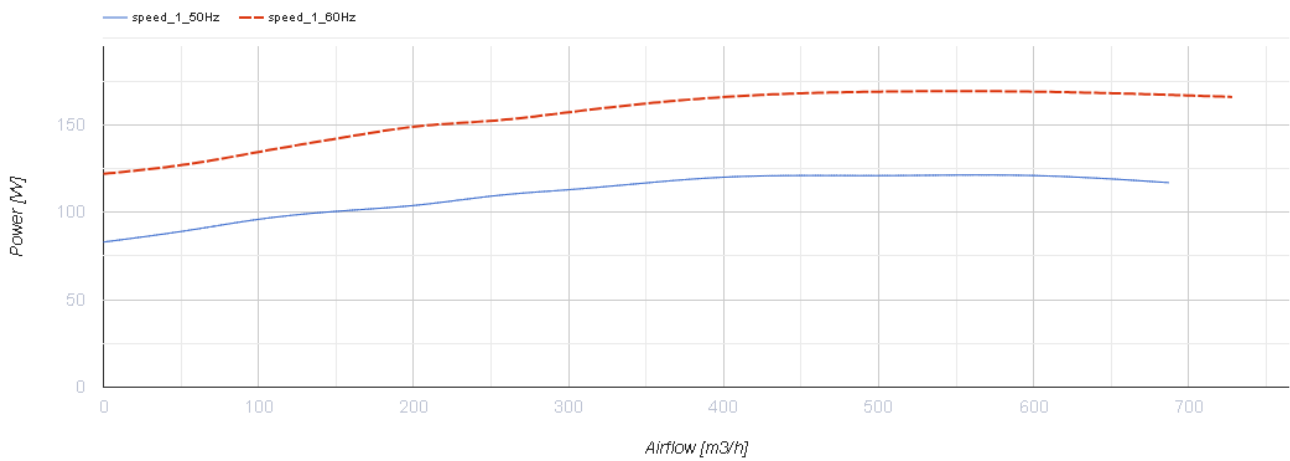
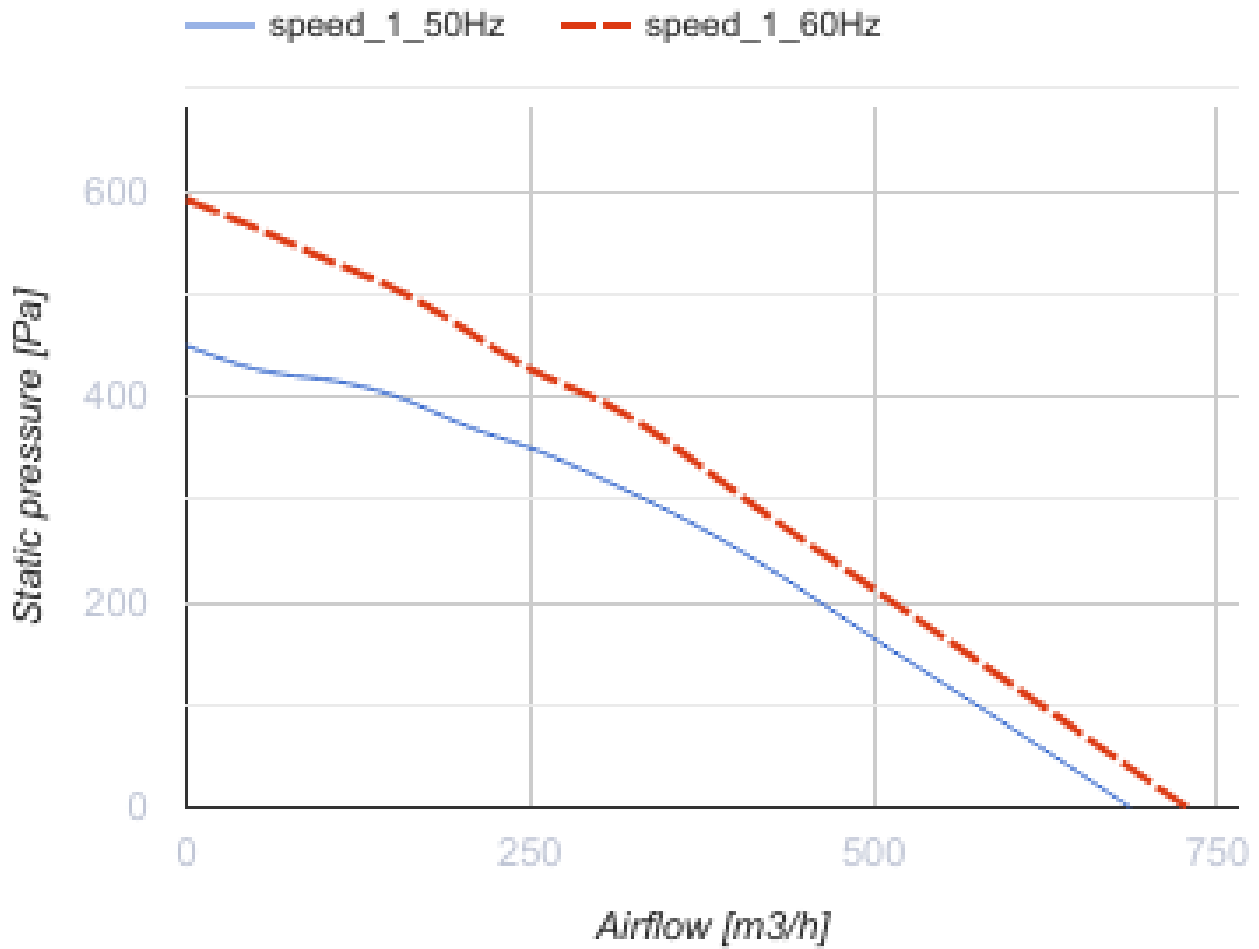

## Dimensions

ØD	ØD1	B	B1	L	L1	L2	L3
158	340	390	350	245	25	20	40

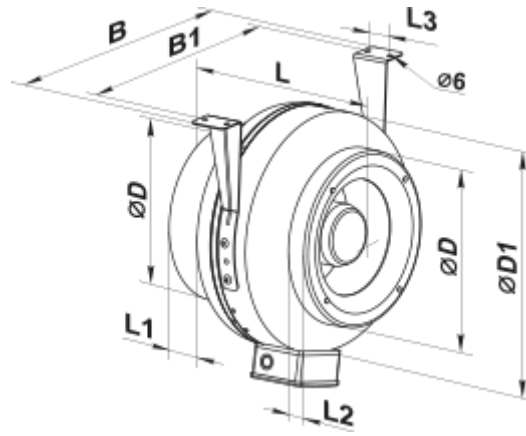

## Ecodesign

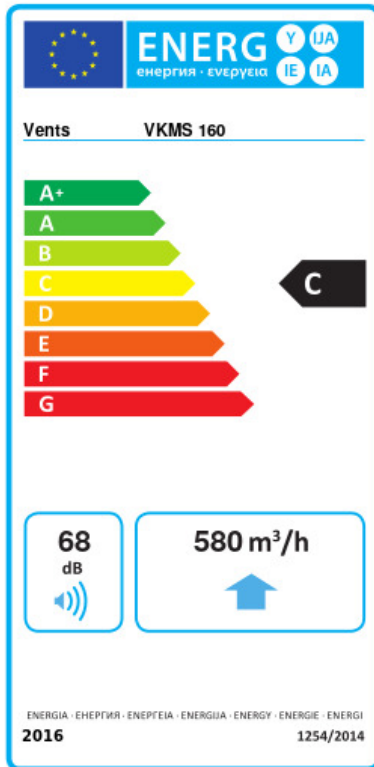

Trademark	Vents					
Model	VKMS 160					
Specific energy consumption (SEC) (kWh/(m <sup>2</sup> /a))	Cold		Average		Warm	
	-51.5	A+	-24.4	C	-8.9	F
Type of ventilation unit	Unidirectional					
Type of drive installed	Variable speed					
Type of heat recovery system	None					
Maximum flow rate (m <sup>3</sup> /h)	580					
Electric power input (W)	121					
Reference flow rate (m <sup>3</sup> /s)	0.113					
Reference pressure difference (Pa)	50					
Specific power input (SPI) (W/(m <sup>3</sup> /h))	0.293					
Control typology	Local demand control					
Maximum external leakage rates (%)	2.7					
Declared typology	RVU UVU					
Sound power level (dB(A))	68					
The annual electricity consumption (AEC) (kWh/a)	Cold		Average		Warm	
	155		155		155	
The annual heating saved (AHS) (kWh/a)	Cold		Average		Warm	
	5536		2830		1280	