

VKMS 200



Inline centrifugal fans in steel casing

- Maximum airflow: 1150
- Sound pressure level LpA at 3 m: 49
- Motor type: AC
- Impeller type: Centrifugal backward curved blades
- Casing material: Coated steel
- Installation in any position

	Unit of measurement	VKMS 200
Connected air duct size	mm	200
Speed	-	1
Minimum supply voltage	V	220
Maximum supply voltage	V	240
Power supply frequency	Hz	50/60
Rated power	W	193
Unit current	A	0.84
Maximum airflow	m ³ /h	1150
Sound pressure level LpA at 3 m	dB(A)	49
Weight	kg	8.3
Transported air temperature (max)	°C	45
Transported air temperature (min)	°C	-25
Ingress protection rating	-	IPX4
Ingress protection rating of the drive	-	IP44

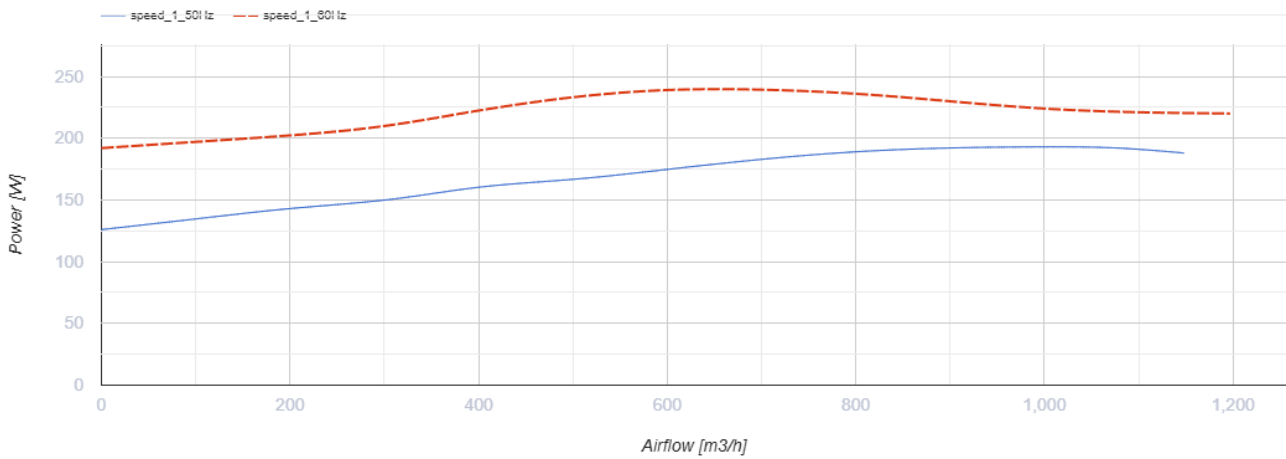
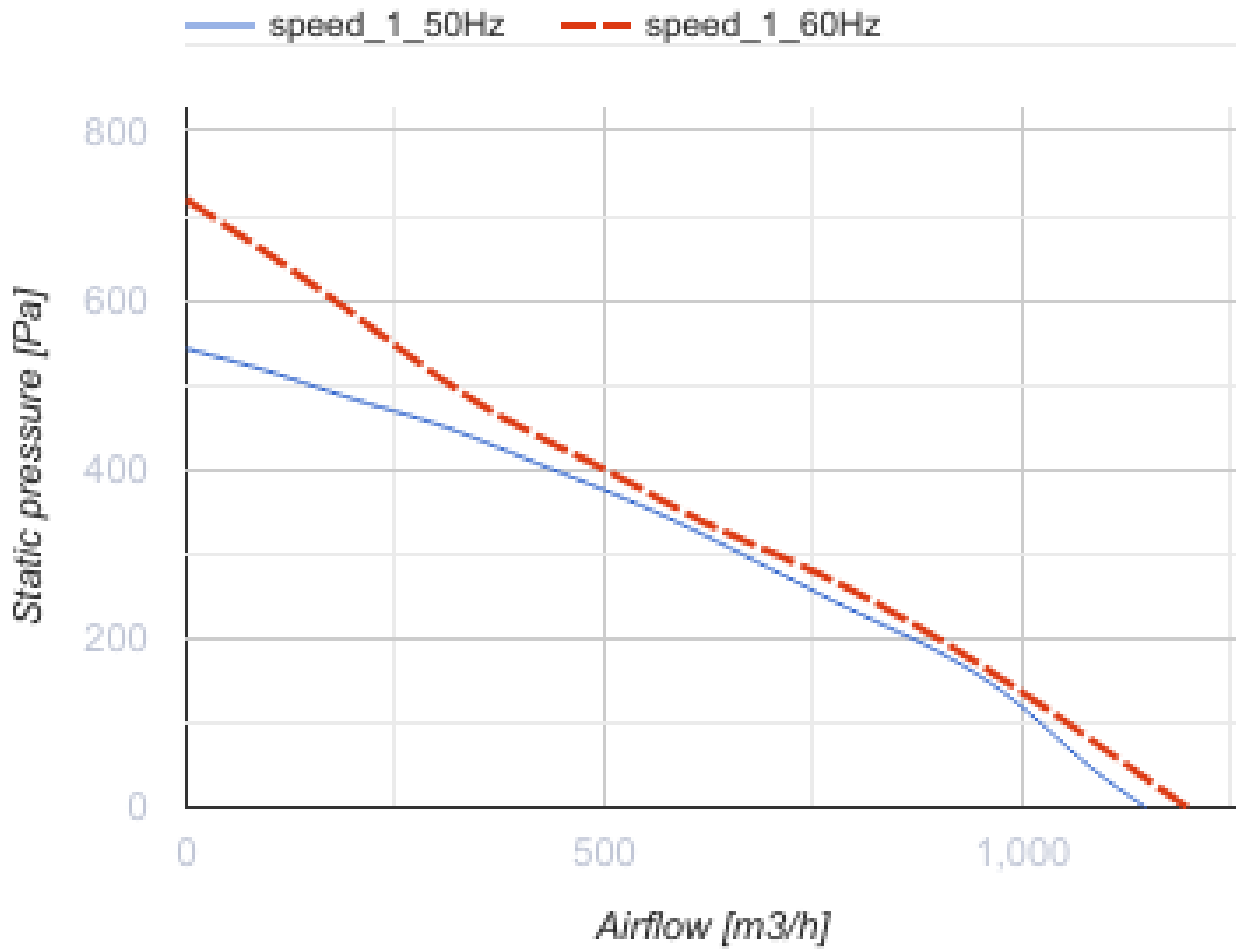

Dimensions

ØD	ØD1	B	B1	L	L1	L2	L3
198	345	395	355	255	25	30	40



Ecodesign

Trademark	Vents
Model	VKMS 200
Type of drive installed	External MSD or VSD
Type of heat recovery system	None
Nominal flow rate (m ³ /s)	0.151
Nominal external pressure (Pa)	353
Maximum external leakage rates (%)	2.7
Static efficiency (%)	32
Declared typology	NRVU UVU
Sound power level (dB(A))	71
Effective electric power input (kW)	0.17