

VKMz 200 Q



Centrifugal inline fans in galvanized casings

- Maximum airflow: 900
- Sound pressure level LpA at 3 m: 48
- Motor type: AC
- Impeller type: Centrifugal backward curved blades
- Casing material: Polypropylene/Thermoplastic elastomer
- Installation in any position

	Unit of measurement	VKMz 200 Q
Connected air duct size	mm	200
Speed	-	1
Minimum supply voltage	V	220
Maximum supply voltage	V	240
Power supply frequency	Hz	50/60
Rated power	W	130
Unit current	A	0.56
Maximum airflow	m ³ /h	900
Sound pressure level LpA at 3 m	dB(A)	48
Weight	kg	5.5
Transported air temperature (max)	°C	50
Transported air temperature (min)	°C	-25
Ingress protection rating	-	IPX4
Ingress protection rating of the drive	-	IP44

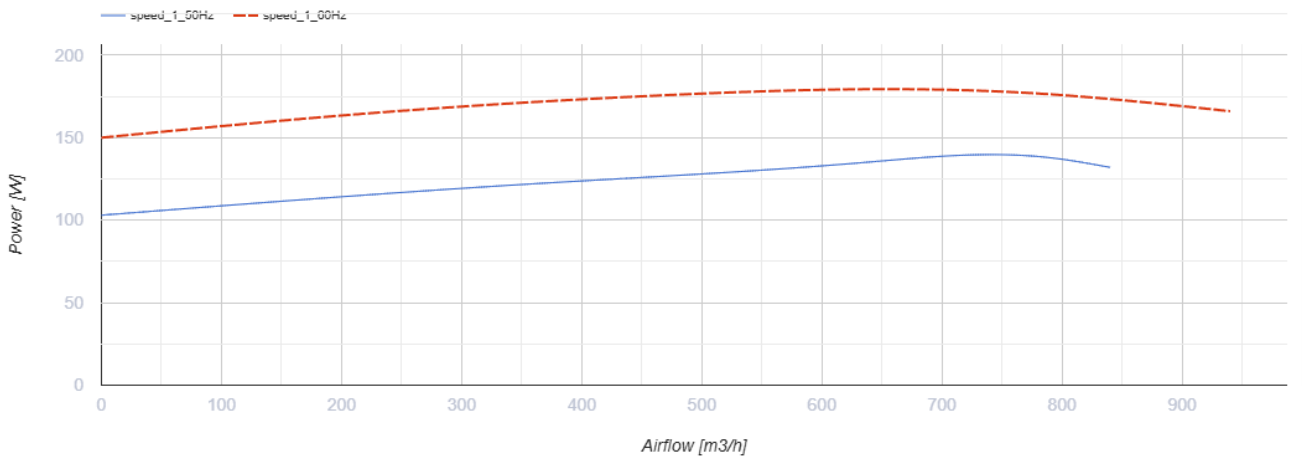
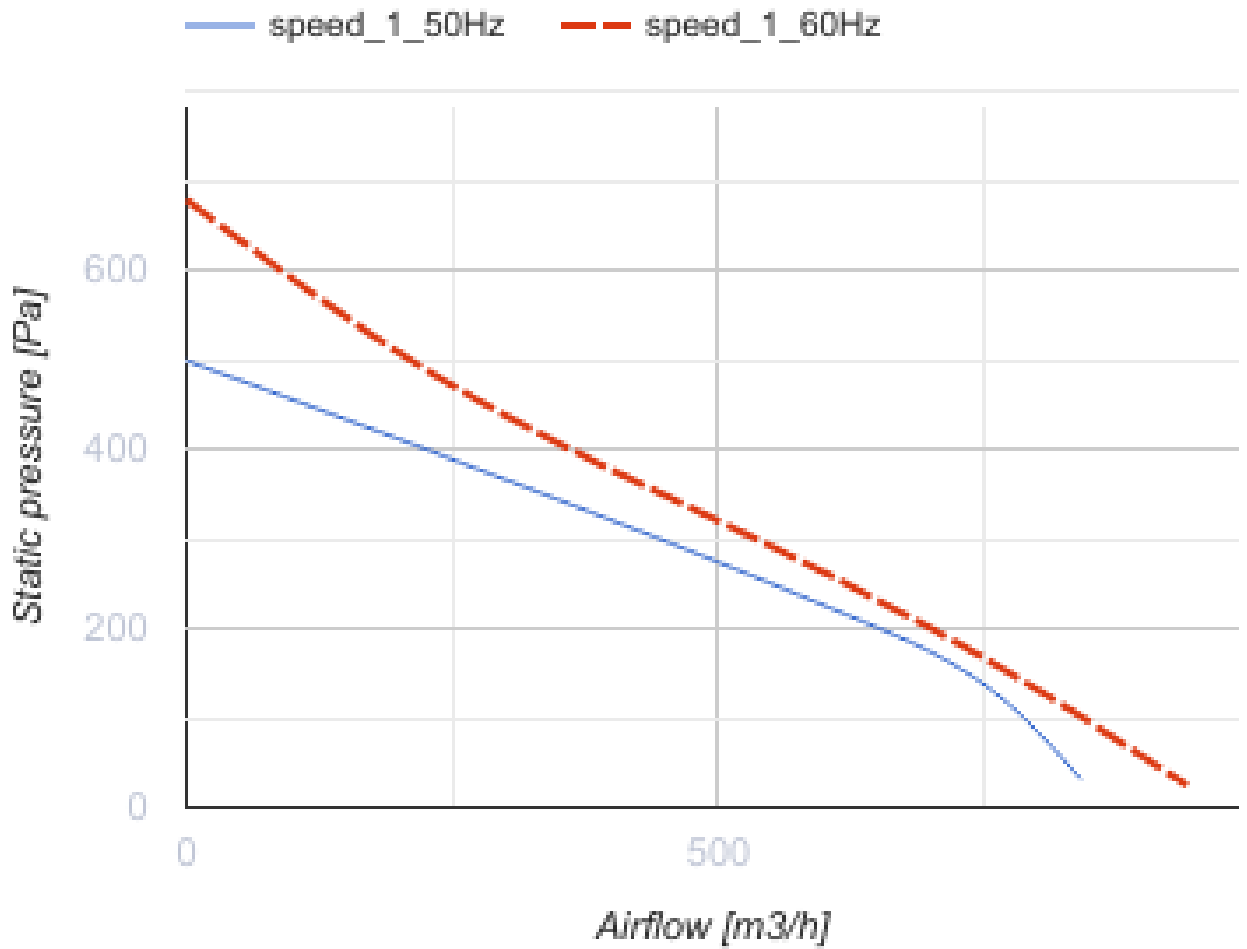

Dimensions

ØD	ØD1	B	B1	L	L1	L2	L3
198	332	340	380	245	25	29	40

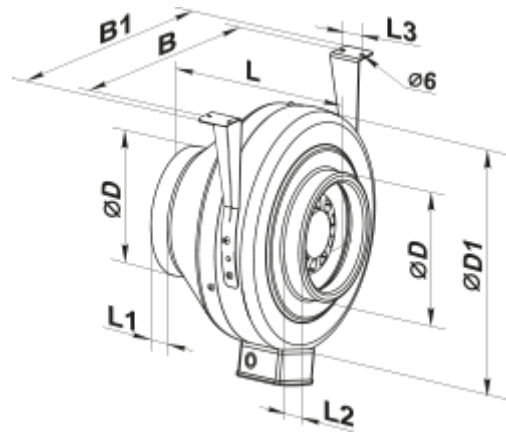

Ecodesign

Trademark	Vents
Model	VKMz 200 Q
Type of drive installed	Integrated VSD
Type of heat recovery system	None
Nominal flow rate (m ³ /s)	0.137
Nominal external pressure (Pa)	308
Maximum external leakage rates (%)	2.7
Static efficiency (%)	33.6
Declared typology	NRVU UVU
Effective electric power input (kW)	0.128
Sound power level (dB(A))	69