

## VKMz 250 Q



Inline centrifugal fans in galvanized casing

- Maximum airflow: 980
- Sound pressure level LpA at 3 m: 51
- Motor type: AC
- Impeller type: Centrifugal backward curved blades
- Casing material: Galvanized steel
- Installation in any position

	Unit of measurement	VKMz 250 Q
Connected air duct size	mm	250
Speed	-	1
Minimum supply voltage	V	220
Maximum supply voltage	V	240
Power supply frequency	Hz	50/60
Rated power	W	134
Unit current	A	0.59
Maximum airflow	m <sup>3</sup> /h	980
Sound pressure level LpA at 3 m	dB(A)	51
Weight	kg	5.1
Transported air temperature (max)	°C	50
Transported air temperature (min)	°C	-25
Ingress protection rating	-	IPX4
Ingress protection rating of the drive	-	IP44

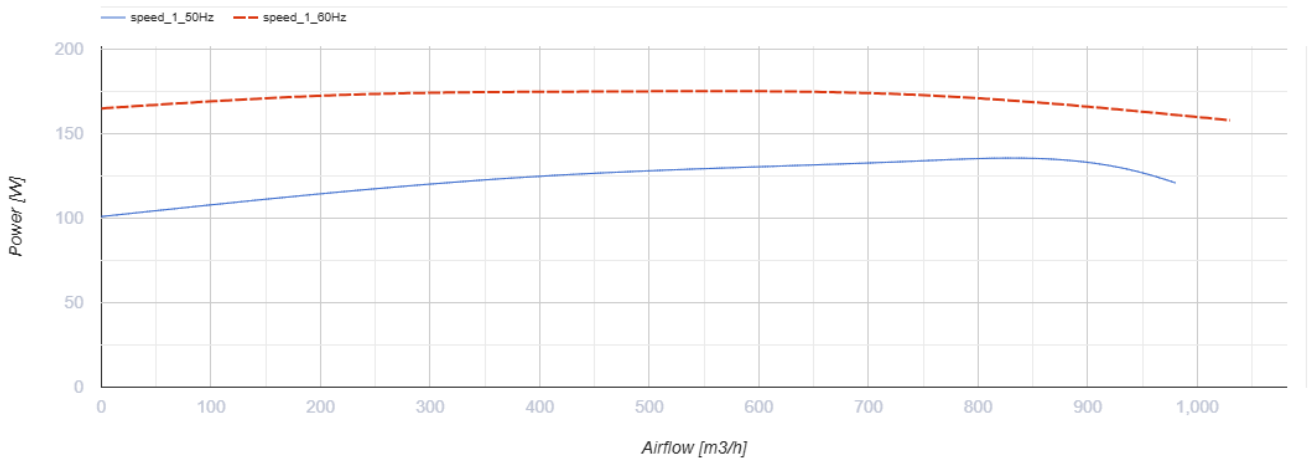
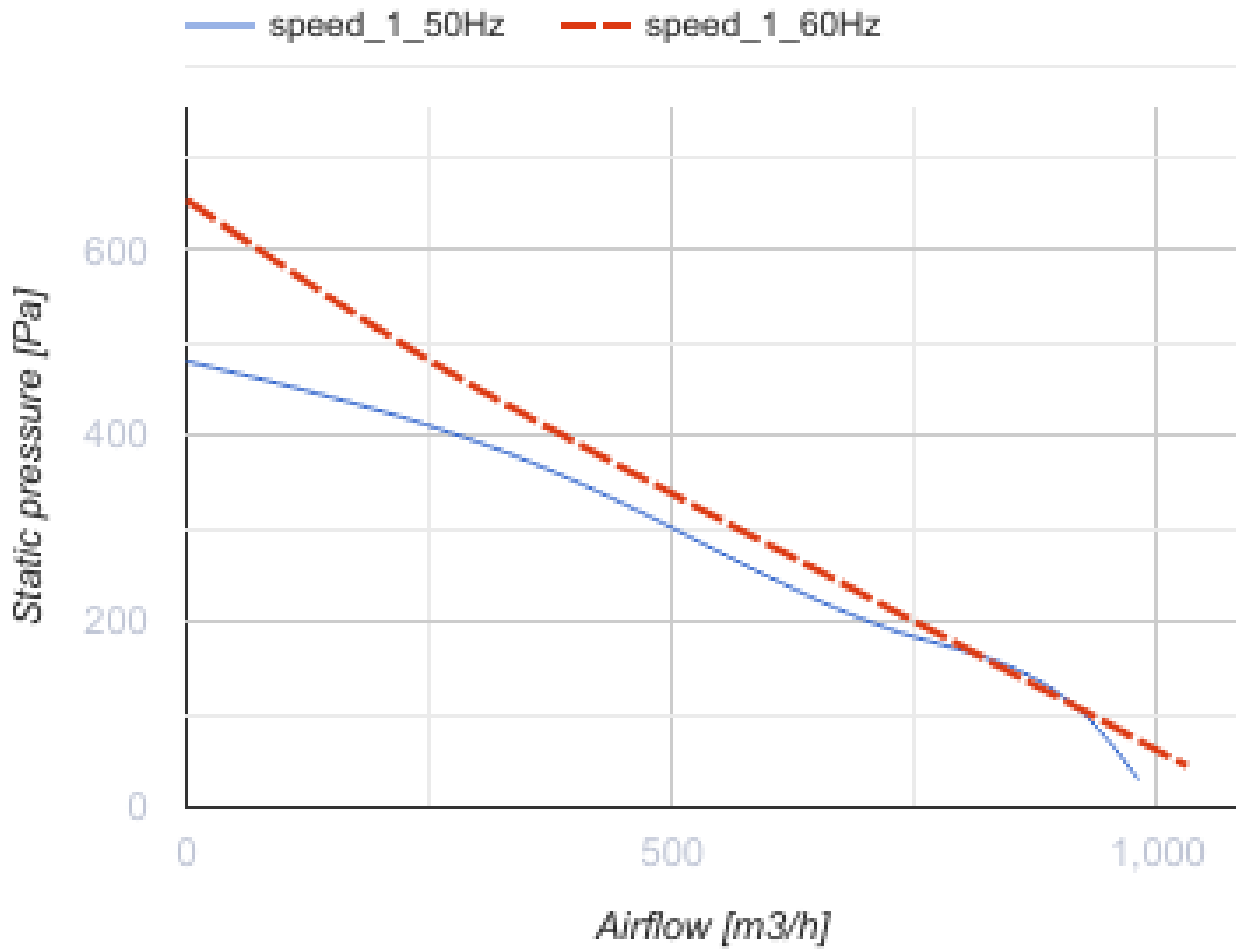

## Dimensions

ØD	ØD1	B	B1	L	L1	L2	L3
249	332	340	380	213	25	29	40

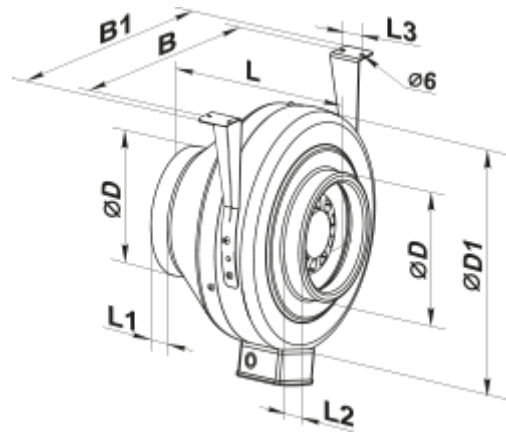

## Ecodesign

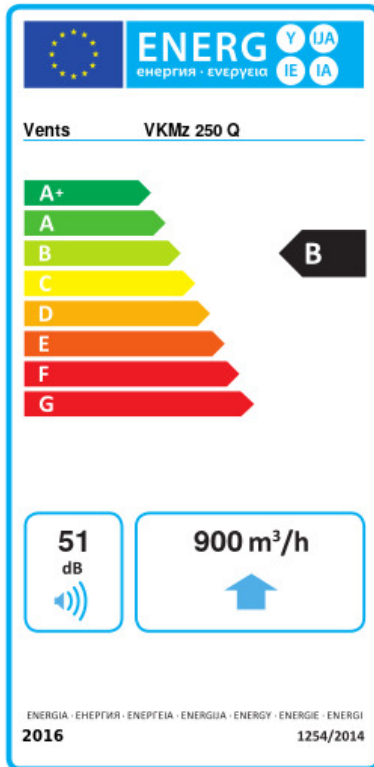

Trademark	Vents					
Model	VKMz 250 Q					
Specific energy consumption (SEC) (kWh/(m <sup>2</sup> /a))	Cold		Average		Warm	
	-53.8	A+	-26.8	B	-11.2	E
Type of ventilation unit	Unidirectional					
Type of drive installed	Variable speed					
Type of heat recovery system	None					
Maximum flow rate (m <sup>3</sup> /h)	900					
Electric power input (W)	134					
Reference flow rate (m <sup>3</sup> /s)	0.175					
Reference pressure difference (Pa)	50					
Specific power input (SPI) (W/(m <sup>3</sup> /h))	0.117					
Control typology	Local demand control					
Maximum external leakage rates (%)	2.7					
Declared typology	RVU UVU					
Sound power level (dB(A))	51					
The annual electricity consumption (AEC) (kWh/a)	Cold		Average		Warm	
	62		62		62	
The annual heating saved (AHS) (kWh/a)	Cold		Average		Warm	
	5536		2830		1280	