

VKOM 315

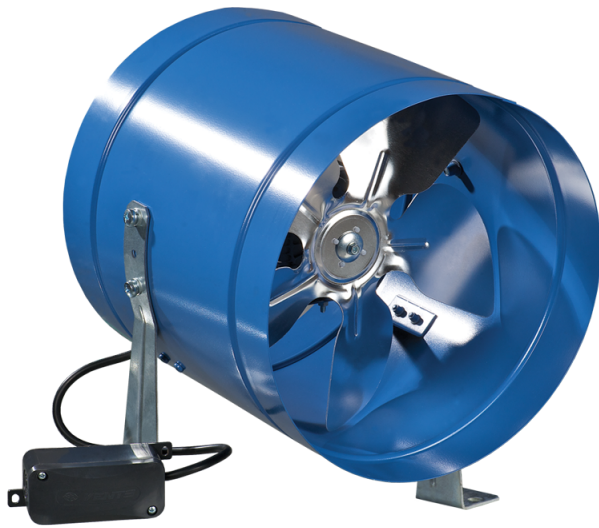

Low pressure axial fans in the steel casing for wall mounting

- Maximum airflow: 1700
- Sound pressure level LpA at 3 m: 42
- Motor type: AC
- Impeller type: Axial
- Casing material: Coated steel
- Installation in any position

	Unit of measurement	VKOM 315
Connected air duct size	mm	315
Speed	-	1
Minimum supply voltage	V	220
Maximum supply voltage	V	240
Power supply frequency	Hz	50/60
Rated power	W	110
Unit current	A	0.75
Maximum airflow	m ³ /h	1700
Sound pressure level LpA at 3 m	dB(A)	42
Weight	kg	4.9
Transported air temperature (max)	°C	40
Transported air temperature (min)	°C	-30
Ingress protection rating	-	IPX4
Ingress protection rating of the drive	-	IP44

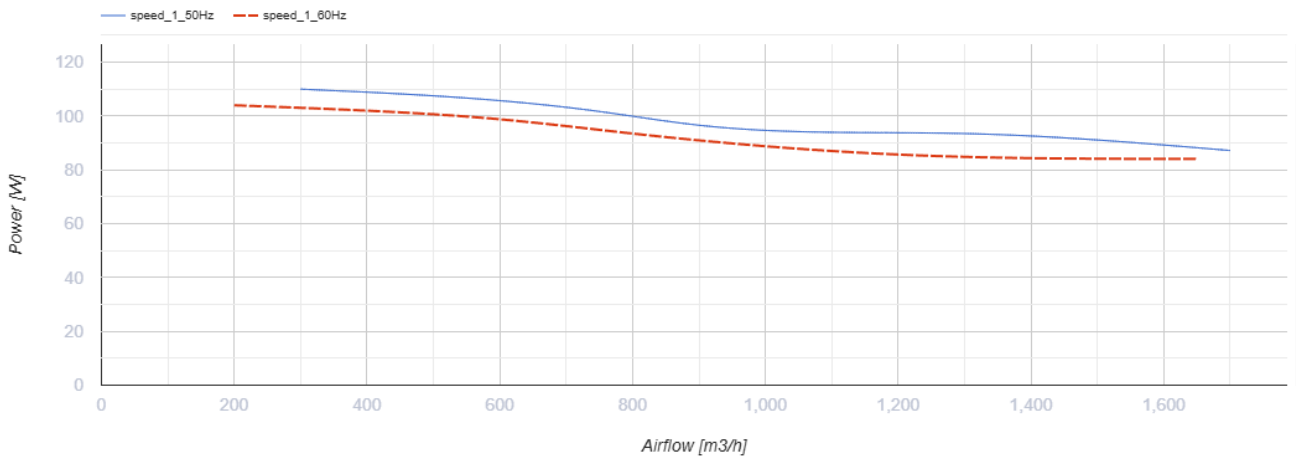
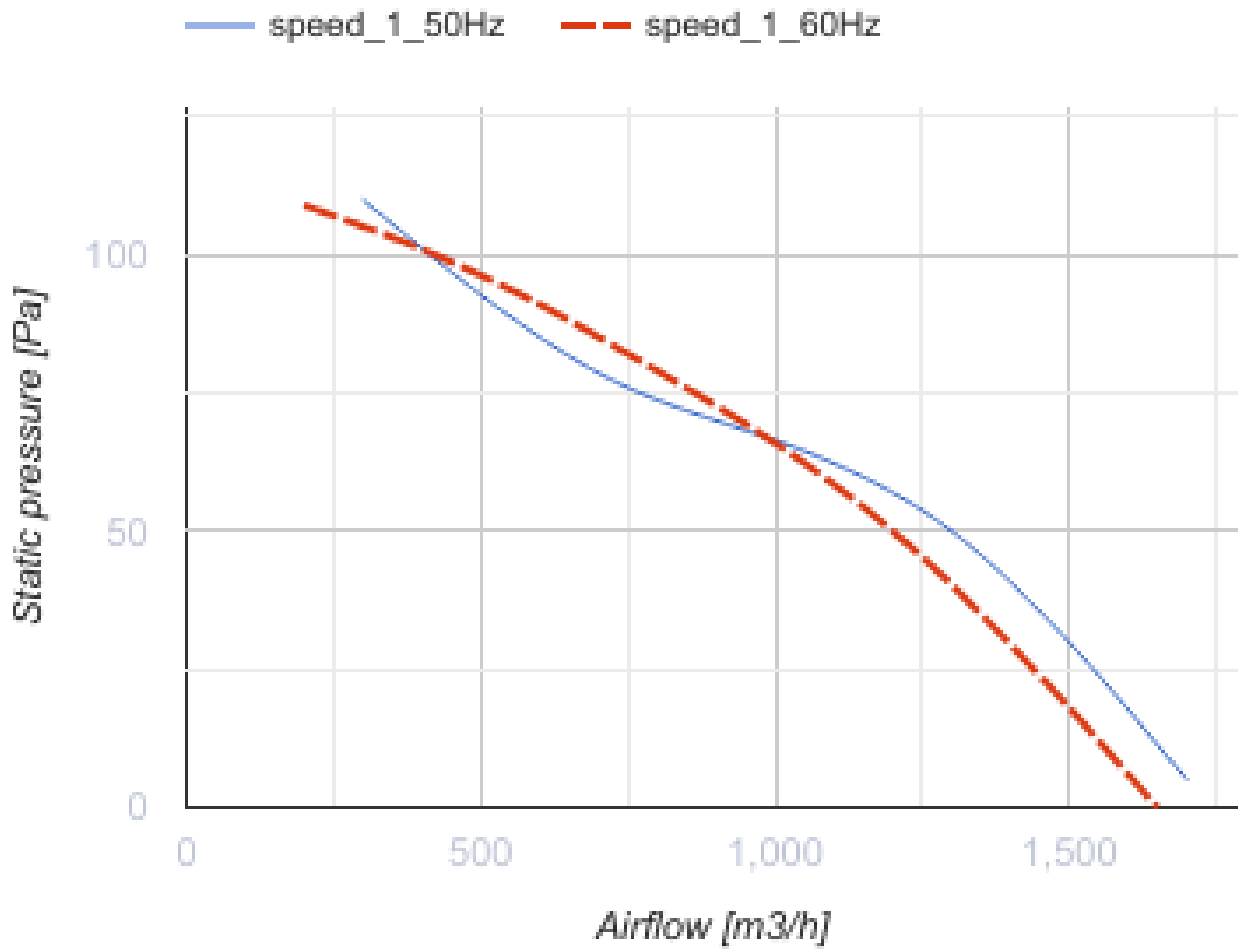

Dimensions

ØD	B	L	L1	L3
315	337	278	55	40

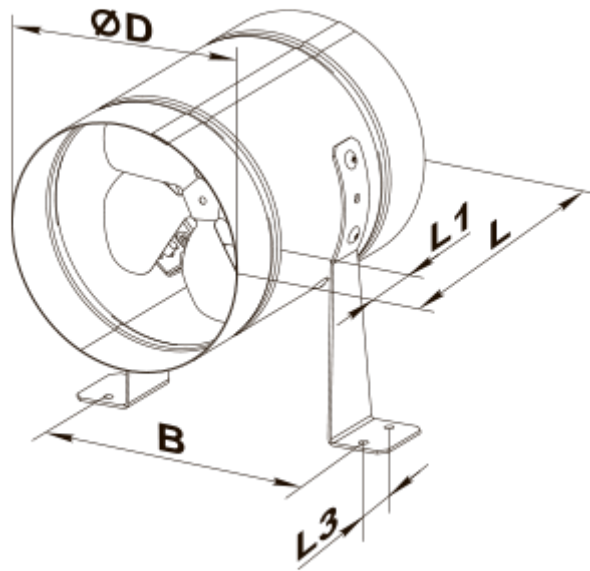

Ecodesign

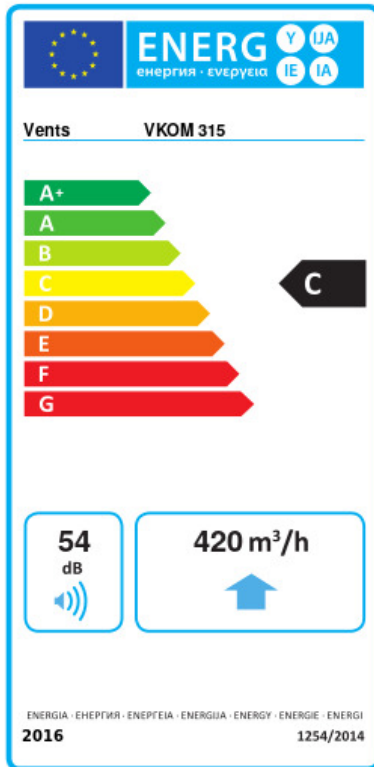

Trademark	Vents					
Model	VKOM 315					
Specific energy consumption (SEC) (kWh/(m ² /a))	Cold		Average		Warm	
	-52.6	A+	-25.6	C	-10.1	E
Type of ventilation unit	Unidirectional					
Type of drive installed	Variable speed					
Type of heat recovery system	None					
Maximum flow rate (m ³ /h)	420					
Electric power input (W)	110					
Reference flow rate (m ³ /s)	0.082					
Reference pressure difference (Pa)	50					
Specific power input (SPI) (W/(m ³ /h))	0.206					
Control typology	Local demand control					
Maximum external leakage rates (%)	2.7					
Declared typology	RVU UVU					
Sound power level (dB(A))	54					
The annual electricity consumption (AEC) (kWh/a)	Cold		Average		Warm	
	109		109		109	
The annual heating saved (AHS) (kWh/a)	Cold		Average		Warm	
	5536		2830		1280	