

# VNV-1A 80 T



Fan units for extract ventilation / built-in fan modules

- Maximum airflow: 63
- Sound pressure level LpA at 3 m: 36
- Control: Wired control panel
- Casing material: Plastic
- Backdraft protection: Backdraft damper
- Timer: Built-in

	Unit of measurement	VNV-1A 80 T	
Connected air duct size	mm	80	
Speed	-	2	
Minimum supply voltage	V	220	
Maximum supply voltage	V	240	
Power supply frequency	Hz	50	
Rated power	W	15	25
Unit current	A	0.12	0.14
Maximum airflow	m <sup>3</sup> /h	35	63
Sound pressure level LpA at 3 m	dB(A)	27	36
Weight	kg	2.7	
Ambient air temperature min	°C	1	
Ambient air temperature max	°C	40	
Ingress protection rating	-	IP55	

## Dimensions

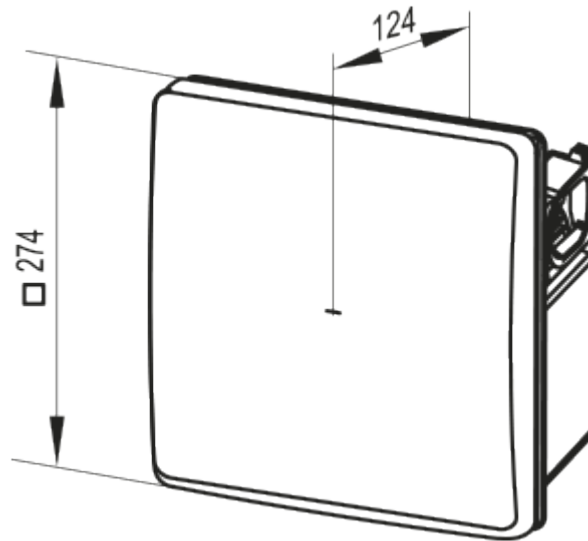

## Accessories

### Speed control switches

Name	Photo	Description
<a href="#">P2-1-300</a>		Switch
<a href="#">P2-1-300</a>		Switch

## Ecodesign

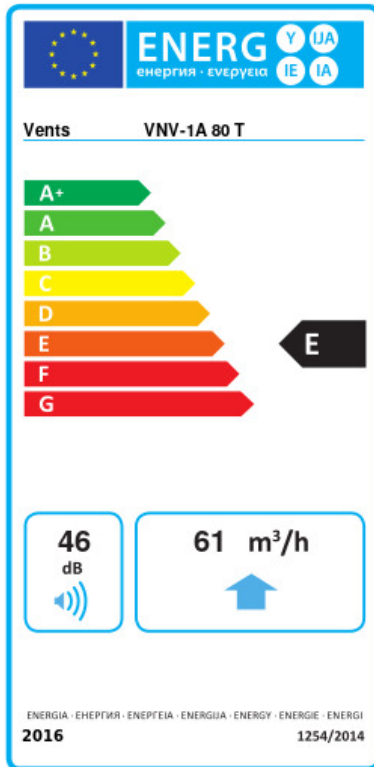

Trademark	Vents					
Model	VNV-1A 80 T					
Specific energy consumption (SEC) (kWh/(m <sup>2</sup> /a))	Cold		Average		Warm	
	-28.5	B	-10.6	E	-0.3	F
Type of ventilation unit	Unidirectional					
Type of drive installed	Multi-speed					
Type of heat recovery system	None					
Maximum flow rate (m <sup>3</sup> /h)	61					
Electric power input (W)	17					
Reference flow rate (m <sup>3</sup> /s)	0.012					
Reference pressure difference (Pa)	50					
Specific power input (SPI) (W/(m <sup>3</sup> /h))	0.281					
Control typology	Clock control					
Maximum external leakage rates (%)	2.7					
Declared typology	RVU UVU					
Sound power level (dB(A))	46					
The annual electricity consumption (AEC) (kWh/a)	Cold	Average		Warm		
	326	326		326		
The annual heating saved (AHS) (kWh/a)	Cold	Average		Warm		
	3667	1874		848		