

# VNV-1E 80 I



Ventilation unit for exhaust ventilation

- Maximum airflow: 100
- Sound pressure level LpA at 3 m: 38
- Control: Wired control panel
- Casing material: Plastic
- Backdraft protection: Backdraft damper

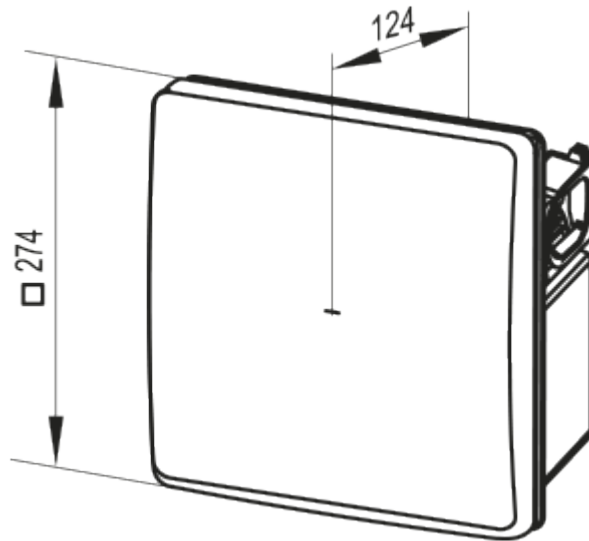

	Unit of measurement	VNV-1E 80 I	
Connected air duct size	mm	80	
Speed	-	2	
Minimum supply voltage	V	220	
Maximum supply voltage	V	240	
Power supply frequency	Hz	50	
Rated power	W	24	29
Unit current	A	0.11	0.13
Maximum airflow	m <sup>3</sup> /h	75	100
Sound pressure level LpA at 3 m	dB(A)	29	38
Weight	kg	2.7	
Ambient air temperature min	°C	1	
Ambient air temperature max	°C	40	
Ingress protection rating	-	IP55	

## Dimensions



## Accessories

### Speed control switches

Name	Photo	Description
<a href="#">P2-1-300</a>		Switch
<a href="#">P2-1-300</a>		Switch

## Ecodesign

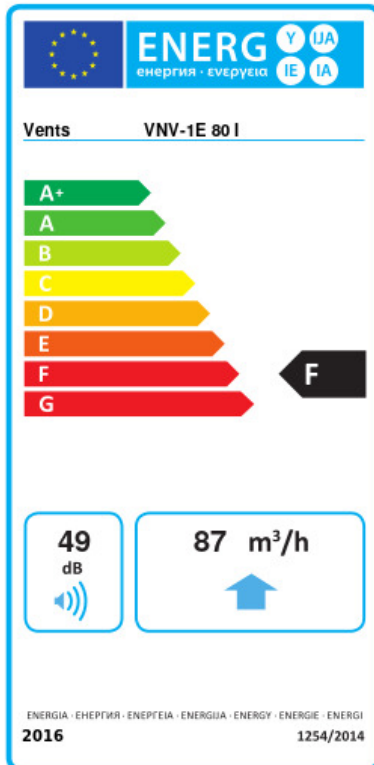

Trademark	Vents					
Model	VNV-1E 80 I					
Specific energy consumption (SEC) (kWh/(m <sup>2</sup> /a))	Cold	Average	Warm			
	-26.7	B	-8.8	F	1.5	G
Type of ventilation unit	Unidirectional					
Type of drive installed	2-speed					
Type of heat recovery system	None					
Maximum flow rate (m <sup>3</sup> /h)	87					
Electric power input (W)	26					
Reference flow rate (m <sup>3</sup> /s)	0.019					
Reference pressure difference (Pa)	50					
Specific power input (SPI) (W/(m <sup>3</sup> /h))	0.338					
Control typology	Clock control					
Maximum external leakage rates (%)	2.7					
Declared typology	RVU UVU					
Sound power level (dB(A))	49					
The annual electricity consumption (AEC) (kWh/a)	Cold	Average	Warm			
	398	398	398			
The annual heating saved (AHS) (kWh/a)	Cold	Average	Warm			
	3667	1874	848			