

VSK 400 E EC



Centrifugal kitchen fans in sound-insulated casing

- Maximum airflow: 4600
- Sound pressure level LpA at 3 m: 60
- Fire resistance class: 120°C within 60 min
- Sound insulation
- Motor type: EC
- Impeller type: Centrifugal impeller with backward curved blades
- Casing material: Aluzinc
- Installation in any position

	Unit of measurement	VSK 400 E EC
Connected air duct size	mm	400
Speed	-	1
Phases	-	1
Minimum supply voltage	V	230
Maximum supply voltage	V	230
Power supply frequency	Hz	50/60
Rated power	W	550
Unit current	A	4.9
Maximum airflow	m ³ /h	4600
rotation speed at 50hz	-	1500
Sound pressure level LpA at 3 m	dB(A)	60
Weight	kg	57
Transported air temperature (max)	°C	120
Transported air temperature (min)	°C	-25
Ingress protection rating	-	IPX4

Dimensions

L	L1	H	H1	B	B1	A	C
670	708	670	708	670	708	252	610

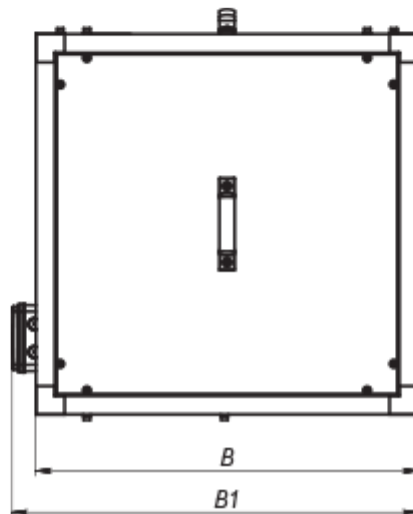
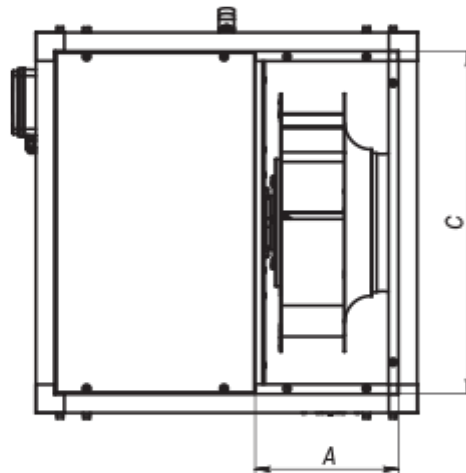
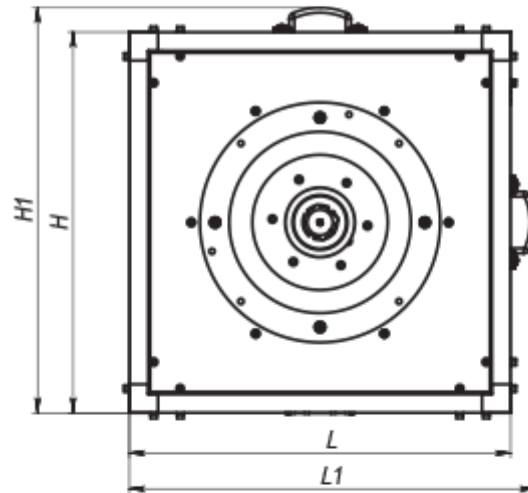

Accessories

Speed controllers

Name	Photo	Description
R-1/010		Speed controller for EC motors