

# VUE 250 H mini A1



Air handling units equipped with an enthalpy cross flow heat exchanger

- Maximum airflow: 260
- Sound pressure level LpA at 3 m: 47
- Heat exchanger type: Cross flow
- Extract filter: G4
- Supply filter: G4 (F8 PM2.5 81 %- option)
- Sound insulation
- Motor type: AC
- Enthalpy heat exchanger
- Control: Remote Control
- Casing material: Galvanized steel

	Unit of measurement	VUE 250 H mini A1
Connected air duct size	mm	125
Speed	-	1
Minimum supply voltage	V	230
Maximum supply voltage	V	230
Power supply frequency	Hz	50/60
Rated power	W	126
Unit current	A	0.6
Maximum airflow	m <sup>3</sup> /h	260
Sound pressure level LpA at 3 m	dB(A)	47
Heat recovery efficiency, max	%	78
Heat exchanger type	-	Cross flow
Heat exchanger material	-	Polystyrene
Weight	kg	26
Extract filter	-	G4
Supply filter	-	G4 (F8 PM2.5 81 %- option)
Transported air temperature (max)	°C	40
Transported air temperature (min)	°C	-25
Ambient air temperature min	°C	1
Ambient air temperature max	°C	40
Ambient air humidity max	%	80
Ingress protection rating	-	IP22

Ingress protection rating of the drive

-

IP44

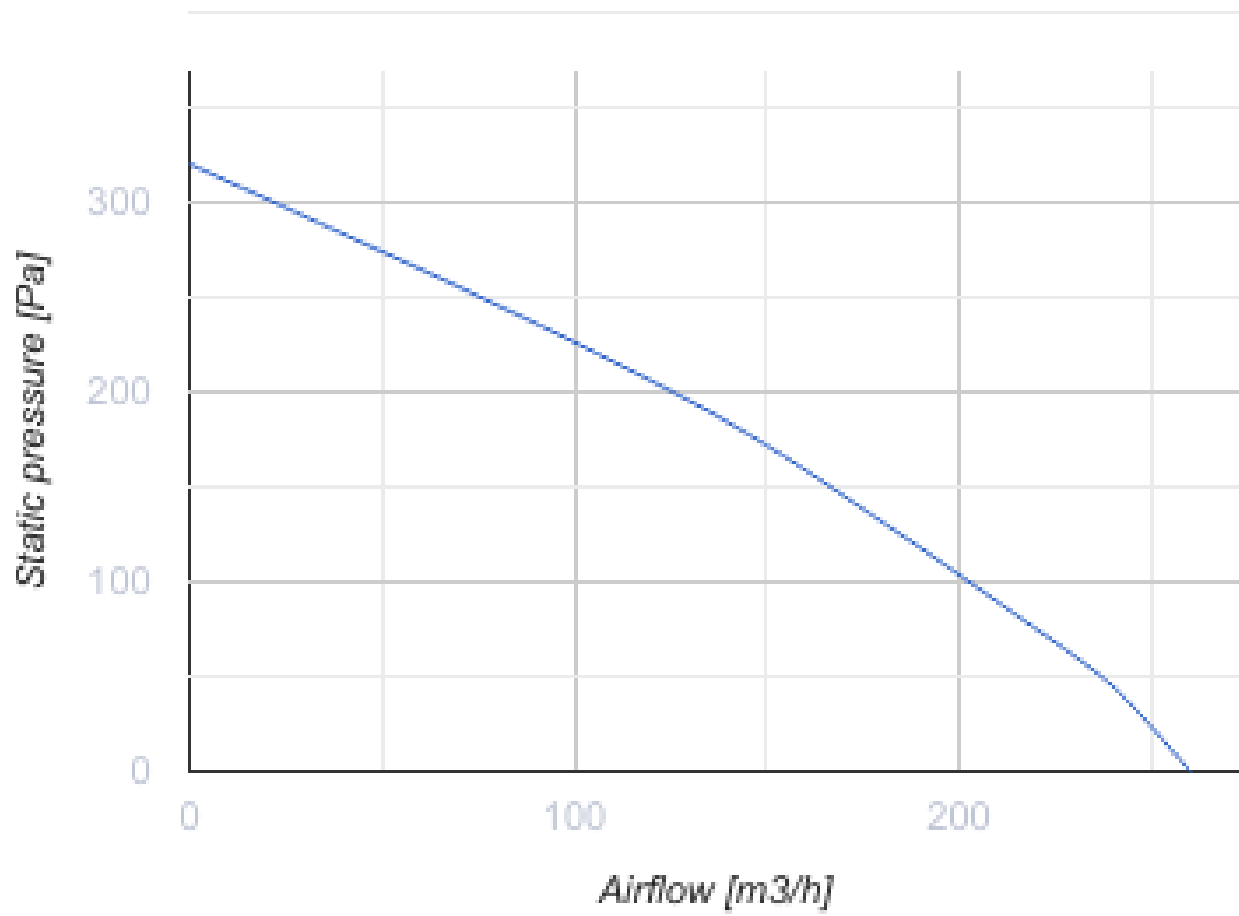

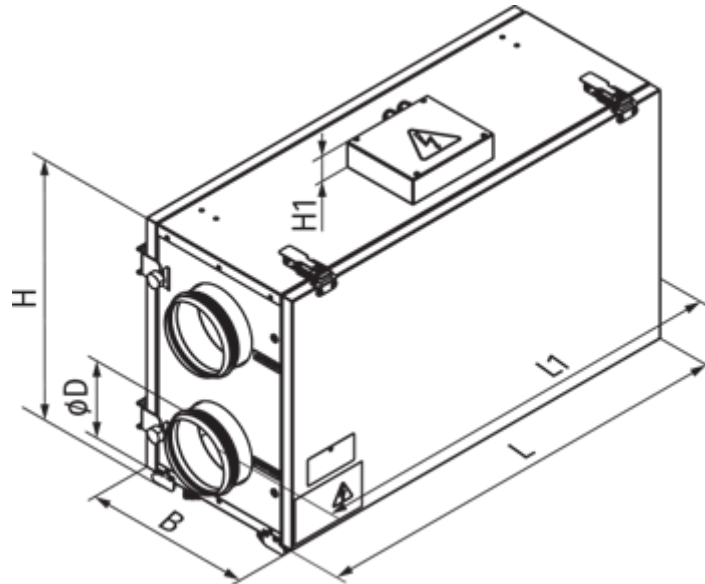

## Dimensions

ØD	B	H	H1	L	L1
125	300	443	43	713	810









## Accessories

### Other accessories



Name	Photo	Description
SF 240x184x40 G4		Panel filter G4
SF 240x184x40 F8		F8 panel filter

### For round ducts

Name	Photo	Description
<a href="#">SR 125/600</a>		Silencer is applied for noise absorption produced during the ventilating equipment operation and spread along the ducting systems
<a href="#">SR 125/900</a>		Silencer is applied for noise absorption produced during the ventilating equipment operation and spread along the ducting systems
<a href="#">SR 125/1200</a>		Silencer is applied for noise absorption produced during the ventilating equipment operation and spread along the ducting systems
<a href="#">SRF 125/600</a>		Silencer is applied for noise absorption produced during the ventilating equipment operation and spread along the ducting systems
<a href="#">SRF 125/900</a>		Silencer is applied for noise absorption produced during the ventilating equipment operation and spread along the ducting systems

<a href="#">SRF 125/2000</a>		Silencer is applied for noise absorption produced during the ventilating equipment operation and spread along the ducting systems
------------------------------	---	---

**For round ducts**

Name	Photo	Description
<a href="#">KOM 125</a>		Spring-loaded backdraft damper for round ducts
<a href="#">KR 125</a>		Air damper for air flow control in round air ducts

## Ecodesign

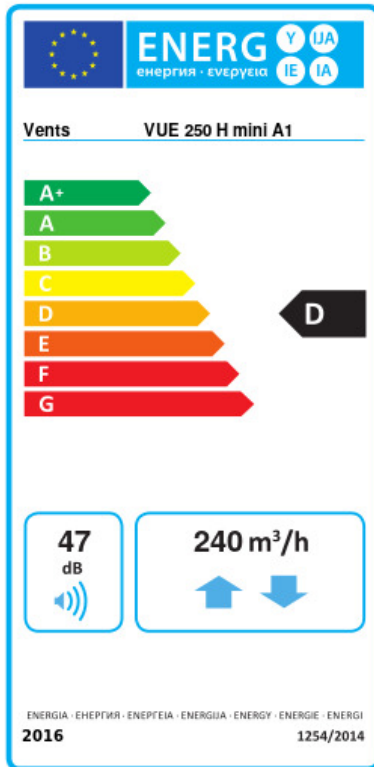

Trademark	Vents					
Model	VUE 250 H mini A1					
Specific energy consumption (SEC) (kWh/(m <sup>2</sup> /a))	Cold		Average		Warm	
	-50.9	A+	-21.6	D	-2.2	F
Type of ventilation unit	Bidirectional					
Type of drive installed	Variable speed					
Type of heat recovery system	Recuperative					
Thermal efficiency of heat recovery (%)	53					
Maximum flow rate (m <sup>3</sup> /h)	240					
Electric power input (W)	170					
Reference flow rate (m <sup>3</sup> /s)	0.056					
Reference pressure difference (Pa)	50					
Specific power input (SPI) (W/(m <sup>3</sup> /h))	0.63					
Control typology	Central demand control					
Maximum internal leakage rates (%)	2.7					
Maximum external leakage rates (%)	2.7					
Declared typology	RVU BVU					
Sound power level (dB(A))	47					
The annual electricity consumption (AEC) (kWh/a)	Cold		Average		Warm	
	1152		615		570	
The annual heating saved (AHS) (kWh/a)	Cold		Average		Warm	
	7097		3628		1640	