

VUT 350 PB EC R A21

Air handling units in heat- and sound-insulated casing



- Maximum airflow: 410
- Sound pressure level LpA at 3 m: 34
- Heat exchanger type: Counter flow
- Extract filter: G4
- Supply filter: F7
- Sound insulation
- Motor type: EC
- Bypass: Auto
- Reheater: Optional
- Preheater: Optional
- BMS protocol: ModBus
- Control: Smartphone
- Casing material: Galvanized steel
- Humidity sensor: Optional
- CO2 sensor: Optional
- VOC sensor: Optional
- PM2.5 sensor: Optional

	Unit of measurement	VUT 350 PB EC R A21
Connected air duct size	mm	160
Speed	-	1
Minimum supply voltage	V	230
Maximum supply voltage	V	230
Power supply frequency	Hz	50/60
Rated power	W	170
Unit current	A	1.3
Maximum airflow	m ³ /h	410
Sound pressure level LpA at 3 m	dB(A)	34
Heat recovery efficiency, max	%	91
Heat exchanger type	-	Counter flow
Heat exchanger material	-	Polystyrene
Weight	kg	70
Extract filter	-	G4
Supply filter	-	F7
Transported air temperature (max)	°C	40
Transported air temperature (min)	°C	-25
Ambient air temperature min	°C	1
Ambient air temperature max	°C	40
Ambient air humidity max	%	80
Ingress protection rating	-	IP22

Ingress protection rating of the drive	-	IP44
--	---	------

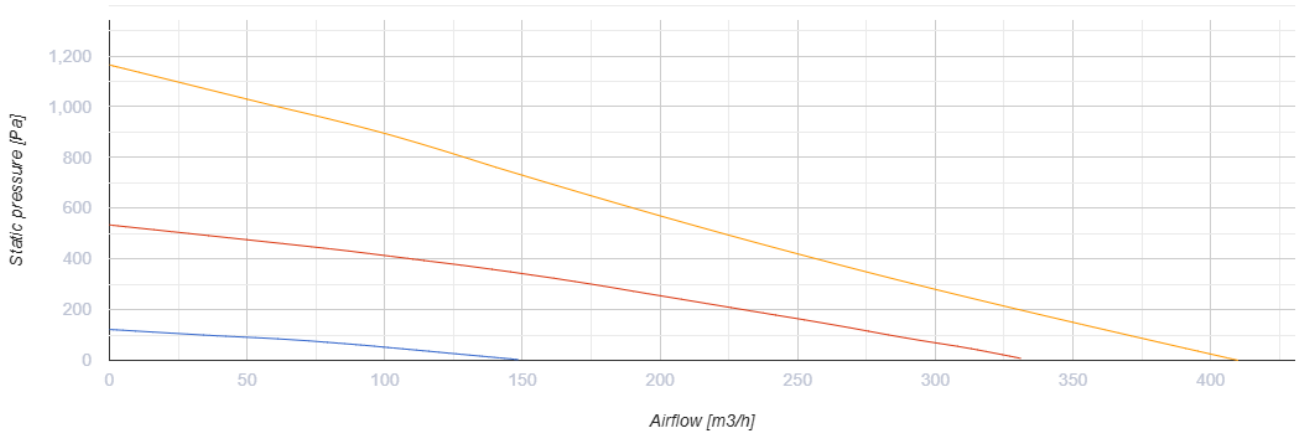

Dimensions

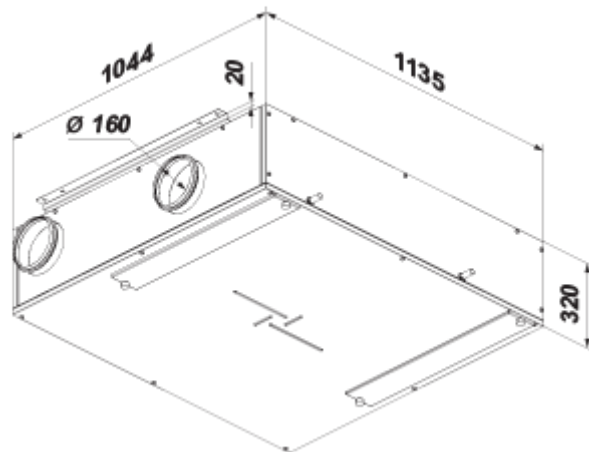





Accessories



Control Panels for AHU

Name	Photo	Description
A22		The A22/A22 WiFi control panels are used for control of industrial and domestic air handling units with an A21 automation system.
A22 WiFi		The A22/A22 WiFi control panels are used for control of industrial and domestic air handling units with an A21 automation system.
A25		The control panel with a sensor display





Sensors



Name	Photo	Description
HV2		Humidity sensor
CO2-1		CO2 sensors
CO2-2		CO2 sensors
HR-S		Electro-mechanical humidistats
DPWC11200		Humidity sensor

VOC sensors

Name	Photo	Description
DPWQ30600		VOC sensors
DPWQ40200		CO2 sensor

Electrical heaters

Name	Photo	Description
NKP 160-0,8-1 A21 V.2		Heater for heat exchanger freeze protection
NKP 160-1,2-1 A21 V.2		Heater for heat exchanger freeze protection
NKP 160-1,7-1 A21 V.2		Heater for heat exchanger freeze protection
NKP 160-2,0-1 A21 V.2		Heater for heat exchanger freeze protection
NKD 160-0,8-1 A21 V.2		Duct heater for supply air post-heating with external control

NKD 160-1,2-1 A21 V.2		Duct heater for supply air post-heating with external control
NKD 160-1,7-1 A21 V.2		Duct heater for supply air post-heating with external control
NKD 160-2,0-1 A21 V.2		Duct heater for supply air post-heating with external control

Condensation drainage

Name	Photo	Description
SH-32		The hydraulic U-trap for condensate drainage from heat exchangers and coolers in ventilation and air conditioning systems



For round ducts

Name	Photo	Description
KRV 160		Air damper for air flow cut-off in round air ducts

Electric actuators

Name	Photo	Description
Belimo LF230		The Belimo LF series actuators are designed for controlling air dampers with cross section up to 0.8 m ² performing protection functions

Other accessories

Name	Photo	Description
SF 603x253x48 G4		Panel filter G4
SF 603x253x48 F7		F7 panel filter

Ecodesign

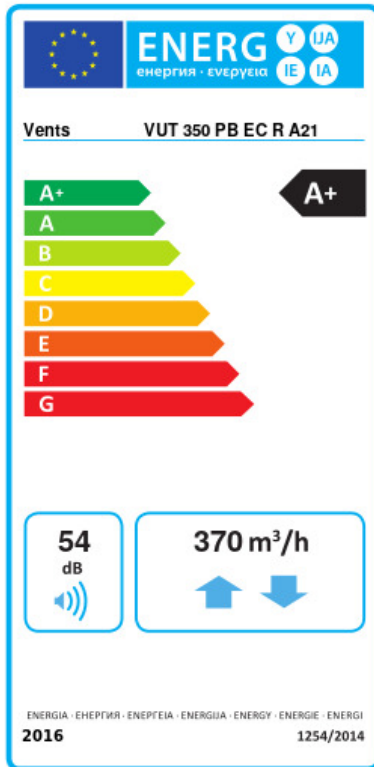

Trademark	Vents					
Model	VUT 350 PB EC R A21					
Specific energy consumption (SEC) (kWh/(m ² /a))	Cold		Average		Warm	
	80.5	A+	42.4	A+	16.6	E
Type of ventilation unit	Bidirectional					
Type of drive installed	Variable speed					
Type of heat recovery system	Recuperative					
Thermal efficiency of heat recovery (%)	83					
Maximum flow rate (m ³ /h)	370					
Electric power input (W)	168					
Reference flow rate (m ³ /s)	0.06					
Reference pressure difference (Pa)	50					
Specific power input (SPI) (W/(m ³ /h))	0.199					
Control typology	Local demand control					
Maximum internal leakage rates (%)	2.7					
Maximum external leakage rates (%)	2.7					
Sound power level (dB(A))	54					
Declared typology	RVU BVU					
The annual electricity consumption (AEC) (kWh/a)	Cold		Average		Warm	
	687		150		105	
The annual heating saved (AHS) (kWh/a)	Cold		Average		Warm	
	8334		4260		1926	