

VUT 900 PBW EC R A21 DTV



Ceiling mounted air handling units in compact heat- and sound-insulated casing with a water heater

- Maximum airflow: 1030
- Sound pressure level LpA at 3 m: 33
- Heat exchanger type: Counter flow
- Extract filter: G4
- Supply filter: G4 (F7 option)
- Sound insulation
- Motor type: EC
- Bypass: Auto
- Reheater: Water
- Preheater: Optional
- BMS protocol: ModBus
- Control: Smartphone
- Casing material: Galvanized steel
- Humidity sensor: Optional
- CO2 sensor: Optional
- VOC sensor: Optional
- PM2.5 sensor: Optional

	Unit of measurement	VUT 900 PBW EC R A21 DTV
Connected air duct size	mm	250
Speed	-	1
Phases	-	1
Minimum supply voltage	V	230
Maximum supply voltage	V	230
Power supply frequency	Hz	50/60
Rated power	W	442
Unit current	A	3
Maximum airflow	m ³ /h	1030
Sound pressure level LpA at 3 m	dB(A)	33
Heat recovery efficiency, max	%	88
Heat exchanger type	-	Counter flow
Heat exchanger material	-	Polystyrene
Weight	kg	112
Extract filter	-	G4
Supply filter	-	G4 (F7 option)
Transported air temperature (max)	°C	40
Transported air temperature (min)	°C	-25
Ambient air temperature min	°C	1

Ambient air temperature max	°C	40
Ambient air humidity max	%	60
Ingress protection rating	-	IP22
Ingress protection rating of the drive	-	IP44

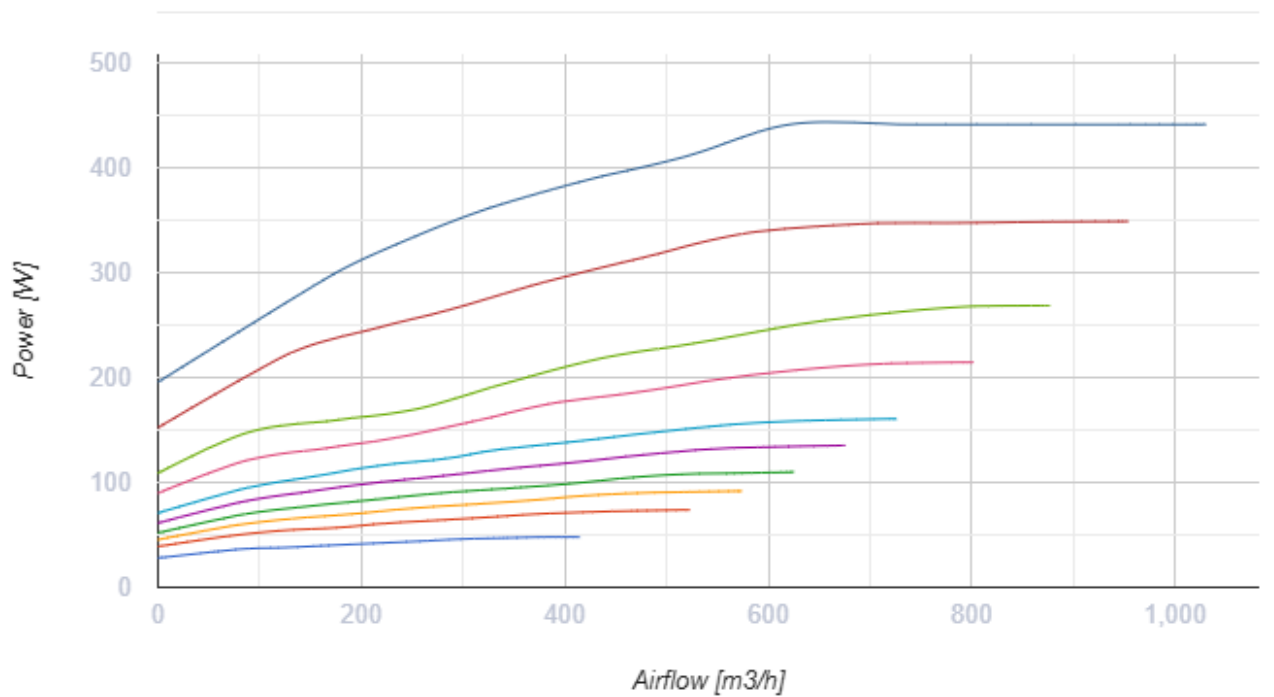
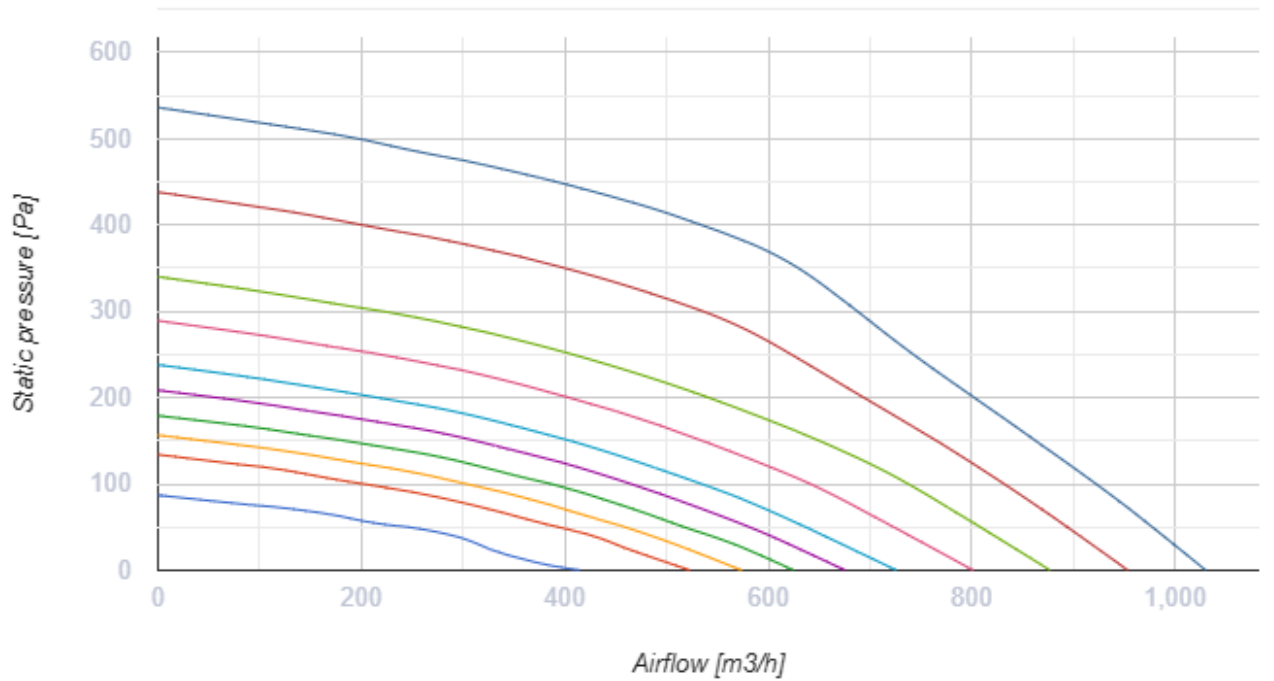

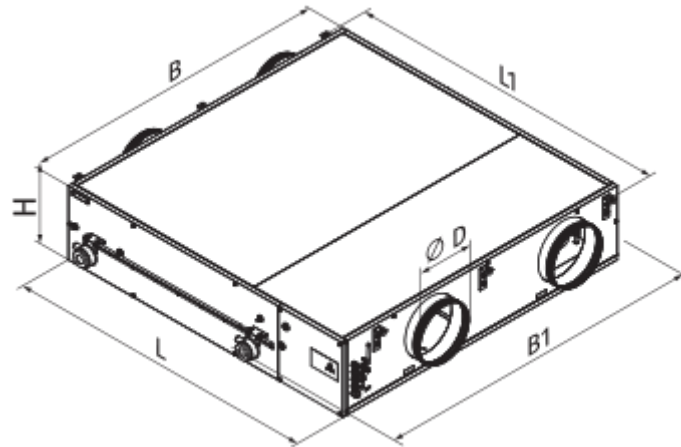

Dimensions

ØD	B	B1	H	L	L1
250	1351	1485	318	1349	1402





Accessories

Control Panels for AHU

Name	Photo	Description
A22		The A22/A22 WiFi control panels are used for control of industrial and domestic air handling units with an A21 automation system.
A22 WiFi		The A22/A22 WiFi control panels are used for control of industrial and domestic air handling units with an A21 automation system.
A25		The control panel with a sensor display

Sensors



Name	Photo	Description
HV2		Humidity sensor
CO2-1		CO2 sensors
CO2-2		CO2 sensors

HR-S		Electro-mechanical humidistats
----------------------	---	--------------------------------



Condensation drainage

Name	Photo	Description
SH-32		The hydraulic U-trap for condensate drainage from heat exchangers and coolers in ventilation and air conditioning systems

For round ducts

Name	Photo	Description
SR 250/600		Silencer is applied for noise absorption produced during the ventilating equipment operation and spread along the ducting systems
SR 250/900		Silencer is applied for noise absorption produced during the ventilating equipment operation and spread along the ducting systems
SR 250/1200		Silencer is applied for noise absorption produced during the ventilating equipment operation and spread along the ducting systems

For round ducts

Name	Photo	Description
KOM 250		Spring-loaded backdraft damper for round ducts
KRV 250		Air damper for air flow cut-off in round air ducts

Electric actuators



Name	Photo	Description
Belimo TF230		The actuators are designed for controlling air dampers with cross section up to 0.4 m ² performing protection functions

Mixing chambers

Name	Photo	Description
USWK 3/4-4		The mixing unit USWK is designed for smooth heat medium flow control in ventilation systems equipped with water heaters or coolers for supply air temperature regulation



USWK 3/4-6		The mixing unit USWK is designed for smooth heat medium flow control in ventilation systems equipped with water heaters or coolers for supply air temperature regulation
USWK 1-6		The mixing unit USWK is designed for smooth heat medium flow control in ventilation systems equipped with water heaters or coolers for supply air temperature regulation
USWK 1-10		The mixing unit USWK is designed for smooth heat medium flow control in ventilation systems equipped with water heaters or coolers for supply air temperature regulation
USWK 1 1/4-10		The mixing unit USWK is designed for smooth heat medium flow control in ventilation systems equipped with water heaters or coolers for supply air temperature regulation
USWK 1 1/4-16		The mixing unit USWK is designed for smooth heat medium flow control in ventilation systems equipped with water heaters or coolers for supply air temperature regulation
USWK 1 1/2-16		The mixing unit USWK is designed for smooth heat medium flow control in ventilation systems equipped with water heaters or coolers for supply air temperature regulation
USWK 1 1/2-25		The mixing unit USWK is designed for smooth heat medium flow control in ventilation systems equipped with water heaters or coolers for supply air temperature regulation
USWK 2-25		The mixing unit USWK is designed for smooth heat medium flow control in ventilation systems equipped with water heaters or coolers for supply air temperature regulation
USWK 2-40		The mixing unit USWK is designed for smooth heat medium flow control in ventilation systems equipped with water heaters or coolers for supply air temperature regulation

Other accessories

Name	Photo	Description
SFK 647x274x27 G4		G4 pocket filter
SFK 647x274x27 F7		F7 pocket filter
SF 647x274x20 G4		Panel filter G4

Electrical heaters

Name	Photo	Description
NKP 250-3,0-1 A21 V.2		Heater for heat exchanger freeze protection

NKP 250-2,0-1 A21 V.2		Heater for heat exchanger freeze protection
NKP 250-1,2-1 A21 V.2		Heater for heat exchanger freeze protection

