

VUTR 250 PE EC L A21



Suspended air handling units with a sorption rotary heat exchanger

- Power of electrical reheater: 700
- Maximum airflow: 310
- Sound pressure level LpA at 3 m: 21
- Heat exchanger type: Rotary
- Extract filter: G4
- Supply filter: G4, F7 (H13 option)
- Sound insulation
- Motor type: EC
- Reheater: Electric
- BMS protocol: ModBus
- Control: Smartphone
- Casing material: Galvanized steel
- Humidity sensor: Optional
- CO2 sensor: Optional
- VOC sensor: Optional
- PM2.5 sensor: Optional

	Unit of measurement	VUTR 250 PE EC L A21
Connected air duct size	mm	160
Speed	-	1
Minimum supply voltage	V	230
Maximum supply voltage	V	230
Power supply frequency	Hz	50/60
Rated power	W	135
Power of electrical reheater	W	700
Unit current	A	4.1
Maximum airflow	m ³ /h	310
Sound pressure level LpA at 3 m	dB(A)	21
Heat recovery efficiency, max	%	87
Heat exchanger type	-	Rotary
Heat exchanger material	-	Aluminum
Weight	kg	56
Extract filter	-	G4
Supply filter	-	G4, F7 (H13 option)
Transported air temperature (max)	°C	40
Transported air temperature (min)	°C	-25
Ambient air temperature min	°C	1

Ambient air temperature max	°C	40
Ambient air humidity max	%	80
Ingress protection rating	-	IP22
Ingress protection rating of the drive	-	IP44

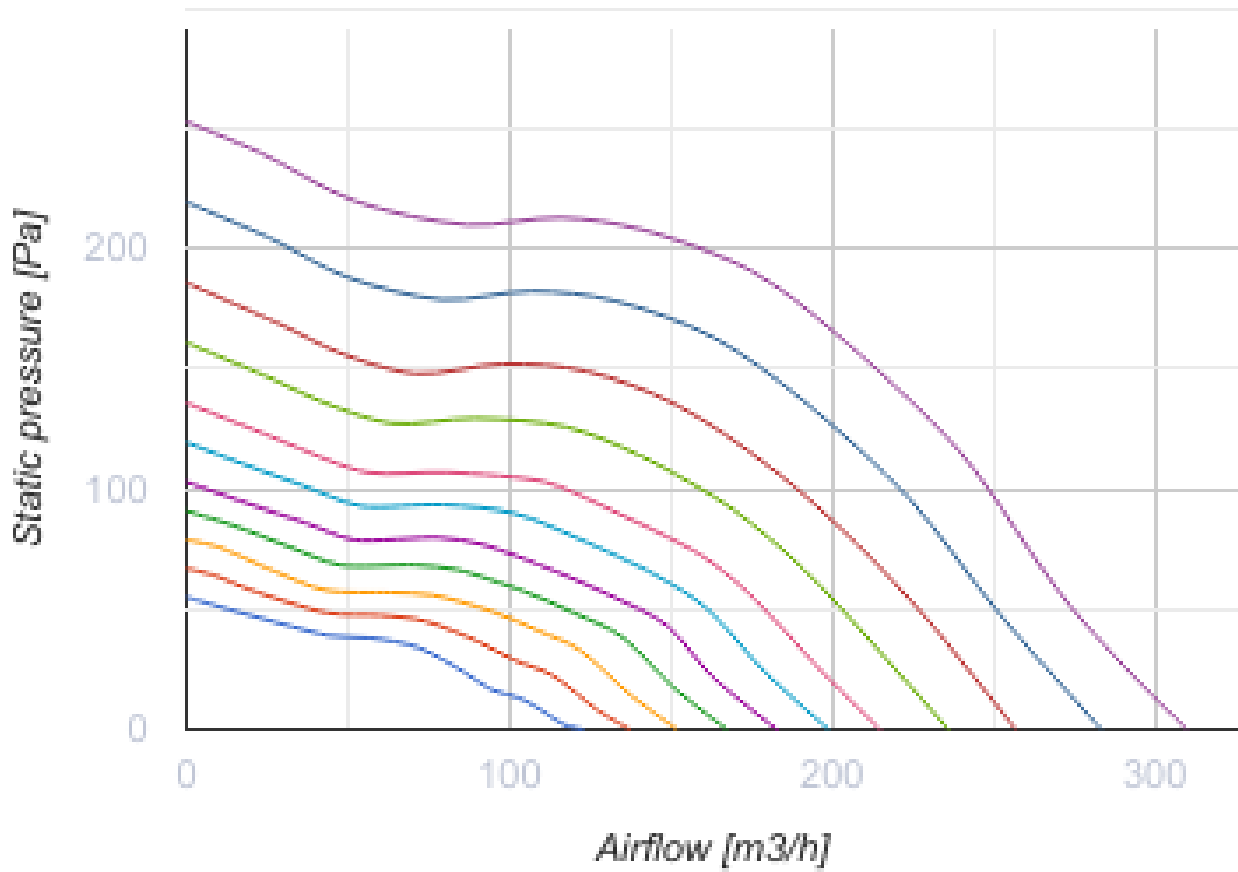

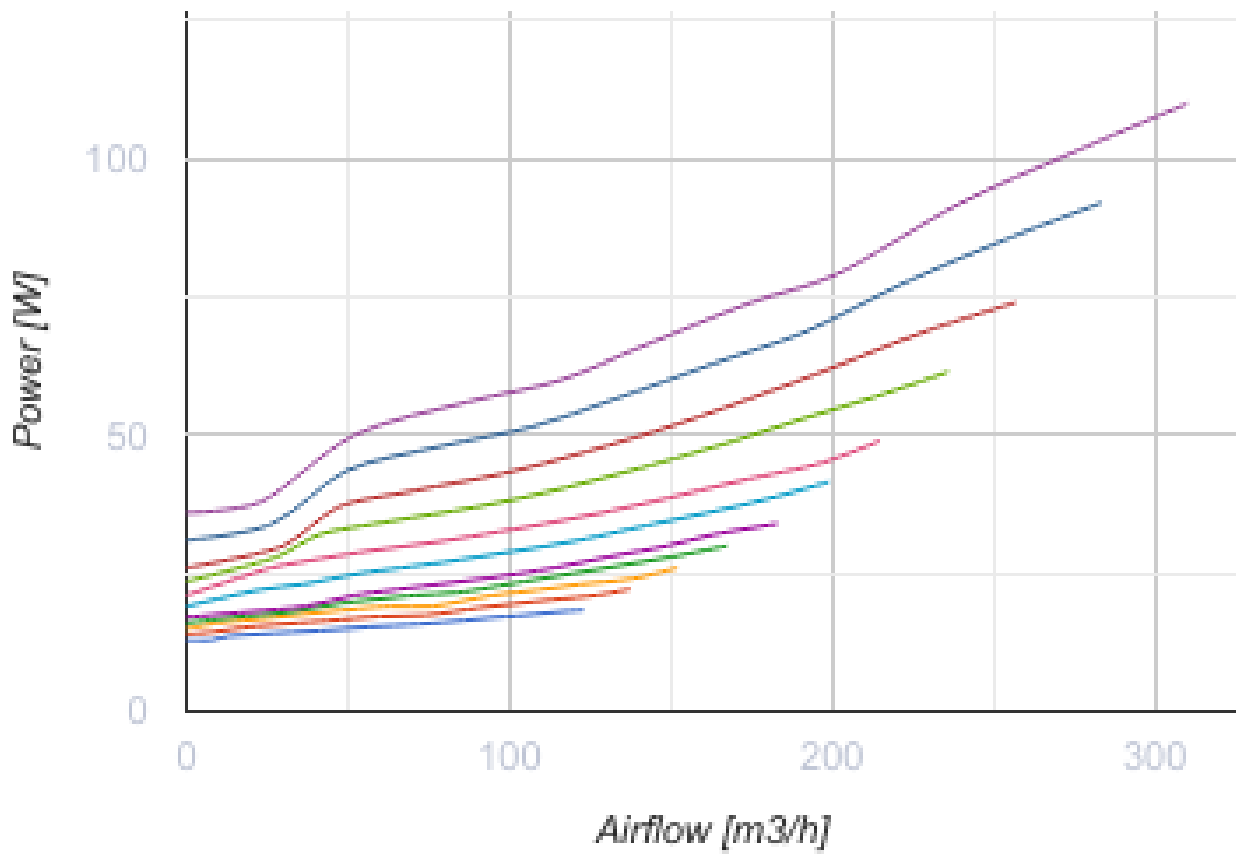

Dimensions

ØD	ØD1	B	H	L	L1
160	125	688	345	1003	1100

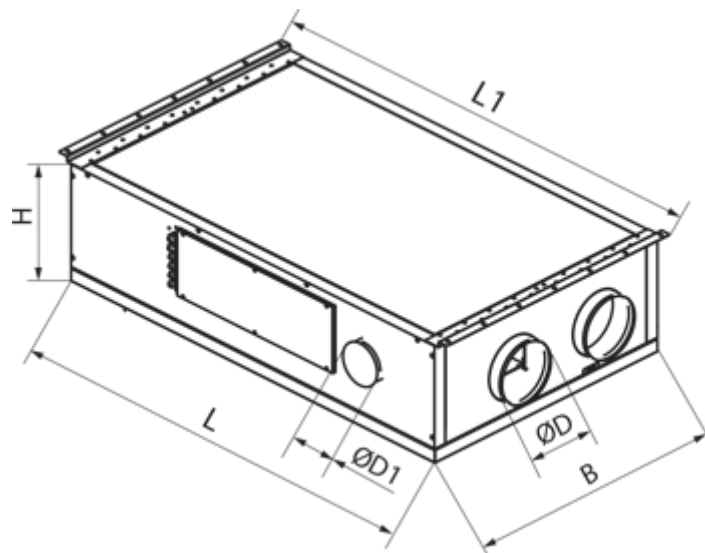



Accessories



Control Panels for AHU

Name	Photo	Description
A25		Touch screen control panel for controlling industrial and residential air handling units



Other accessories

Name	Photo	Description
A22		Control panels for controlling industrial and residential air handling units
A22 WiFi		Control panels for controlling industrial and residential air handling units

Sensors

Name	Photo	Description
HR-S		Electro-mechanical humidistat
HV2		Humidity sensor

For round ducts

Name	Photo	Description
KOM 160		Backdraught damper with spring-loaded plates for shutting off air flow in round air ducts
KRV 160		Air dampers for automatic air flow control in round ducts

Electric actuators

Name	Photo	Description
Belimo TF230		The actuators are designed for controlling air dampers with cross section up to 0.4 m ² performing protection functions

Other accessories

Name	Photo	Description
------	-------	-------------

SF 260x220x48 G4		Panel filter G4
SF 260x220x48 F7		F7 panel filter

Flanges

Name	Photo	Description
KH-1		Kitchen hood for removing combustion products, vapors and odors from the air

