

# VUTR 400 WH EC A18



Air handling units in heat- and sound-insulated casing with an electric or a water heater

- Maximum airflow: 400
- Sound pressure level LpA at 3 m: 45
- Heat exchanger type: Rotary
- Extract filter: G4
- Supply filter: G4
- Sound insulation
- Motor type: EC
- Reheater: Water
- Control: Remote Control
- Casing material: Galvanized steel
- Humidity sensor: Optional
- CO2 sensor: Optional
- VOC sensor: Optional
- PM2.5 sensor: Optional

	Unit of measurement	VUTR 400 WH EC A18
Connected air duct size	mm	160
Speed	-	1
Minimum supply voltage	V	230
Maximum supply voltage	V	230
Power supply frequency	Hz	50/60
Rated power	W	290
Unit current	A	1.2
Maximum airflow	m <sup>3</sup> /h	400
Sound pressure level LpA at 3 m	dB(A)	45
Heat recovery efficiency, max	%	95
Heat exchanger type	-	Rotary
Heat exchanger material	-	Aluminum
Weight	kg	112
Extract filter	-	G4
Supply filter	-	G4
Transported air temperature (max)	°C	40
Transported air temperature (min)	°C	-25
Ambient air temperature min	°C	1
Ambient air temperature max	°C	40

Ambient air humidity max	%	80
Ingress protection rating	-	IP22
Ingress protection rating of the drive	-	IP44

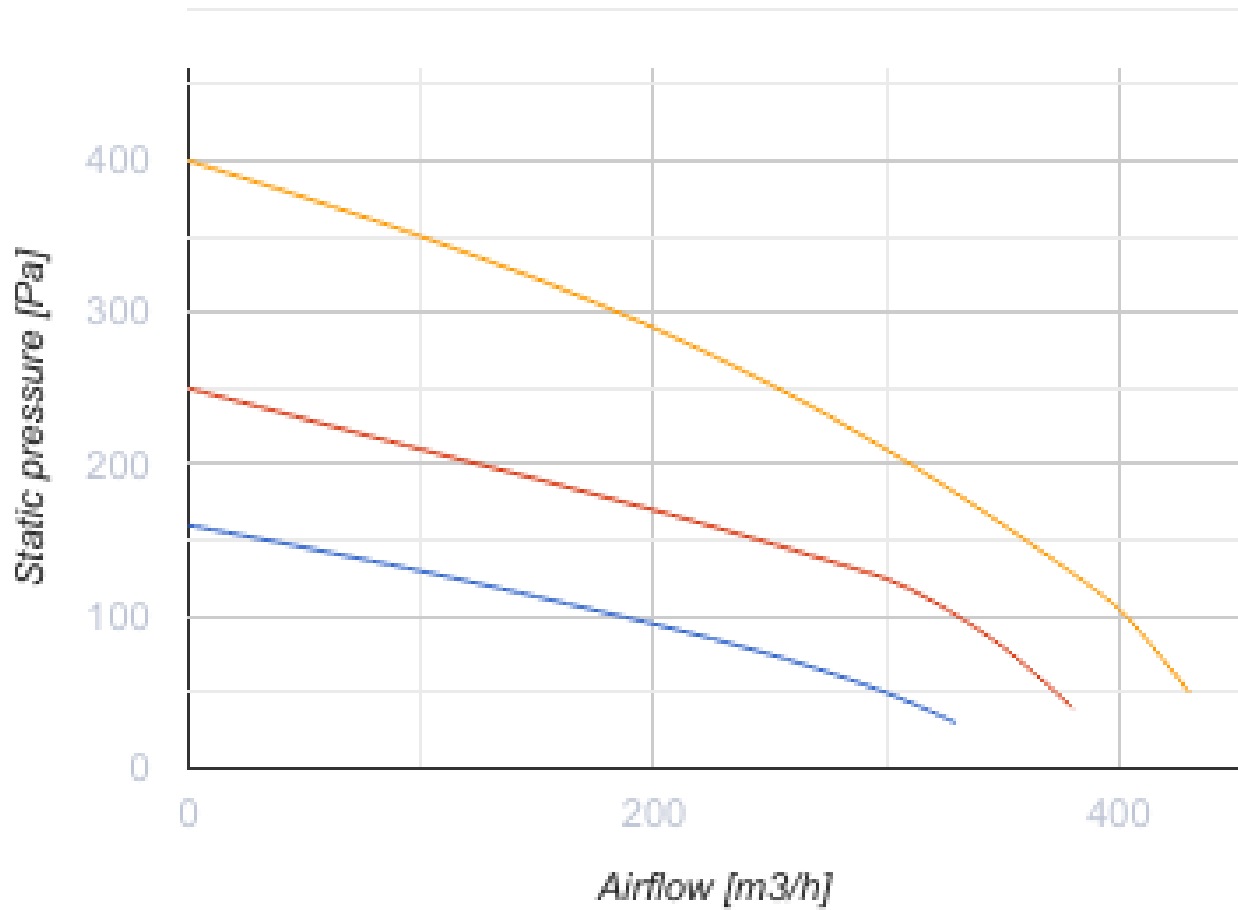

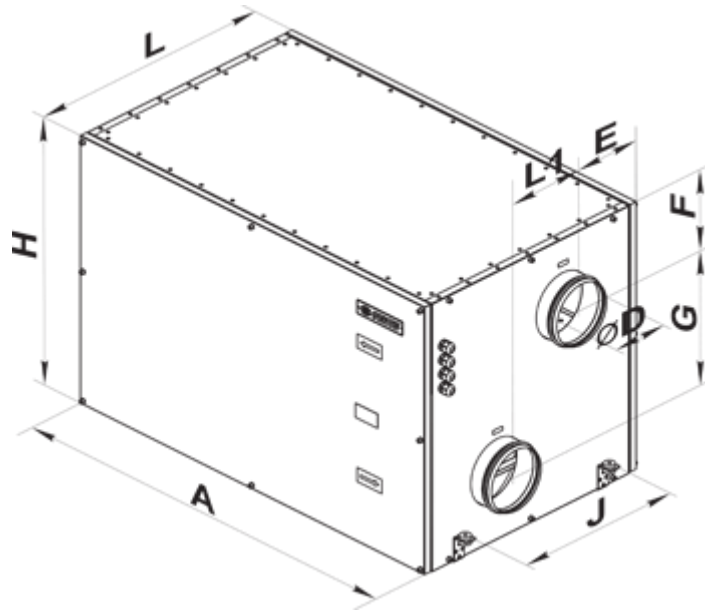

## Dimensions

ØD	A	E	F	G	J	H	L	L1
159	1050	225	167	333	440	670	648	200





## Accessories

### VOC sensors

Name	Photo	Description
<a href="#">DPWQ30600</a>		VOC sensors
<a href="#">DPWQ40200</a>		CO2 sensor



### Sensors

Name	Photo	Description
<a href="#">DPWC11200</a>		Humidity sensor
<a href="#">HR-S</a>		Electro-mechanical humidistats
<a href="#">HV2</a>		Humidity sensor

### Mixing chambers

Name	Photo	Description
<a href="#">USWK 3/4-4</a>		The mixing unit USWK is designed for smooth heat medium flow control in ventilation systems equipped with water heaters or coolers for supply air temperature regulation



### For round ducts

Name	Photo	Description
<a href="#">KOM 160</a>		Spring-loaded backdraft damper for round ducts
<a href="#">KRV 160</a>		Air damper for air flow cut-off in round air ducts

### Electric actuators

Name	Photo	Description
<a href="#">Belimo TF230</a>		The actuators are designed for controlling air dampers with cross section up to 0.4 m <sup>2</sup> performing protection functions

### Other accessories

Name	Photo	Description
SFK 393x235x27 G4		G4 pocket filter
SF 600x324x48 G4		Panel filter G4
PCOS004850		The control module is designed for connection of the pCO series controllers (except for pCOB) to ventilation control systems in compliance with the Modbus RS485 protocol.