

# FLEXIBLE DUCTS AND FITTINGS

isovent



polyvent

aluvent



thermovent



 **VENTS**

2011

*Fresh air in  
your house!*



**Energy saving ventilation.  
Air handling units  
(Catalogue no. 2)**

Energy saving supply and exhaust units and air handling units with heat recovery with air capacity up to 6500 m<sup>3</sup>/h.



**Air handling units  
AIRVENTS  
(Catalogue no. 3)**

Energy saving air handling units with air capacity up to 40 000 m<sup>3</sup>/h, for use in large residential, industrial and commercial objects.

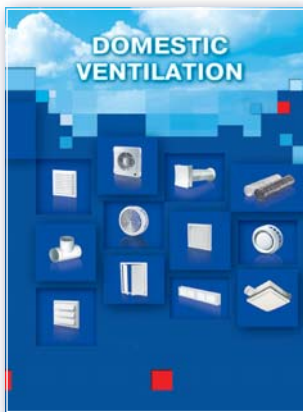

**Domestic ventilation  
(Catalogue no. 6)**

Domestic ventilation: fans, mono-pipe exhaust kitchen and bathroom fans, air distribution units, air ducts and connecting elements, access doors, ventilation kits.



**Domestic fans  
(Catalogue no. 7)**

Domestic fans with air capacity up to 365 m<sup>3</sup>/h with extra functions: timer, humidity sensor, motion sensor, etc. Applied for premises up to 30 m<sup>2</sup>.

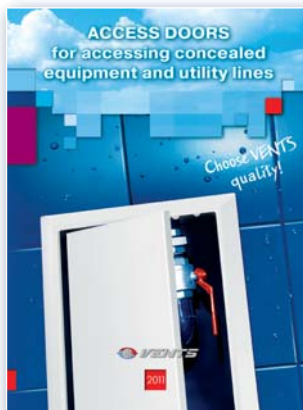

**Access doors  
(Catalogue no. 10)**

Plastic and metal access doors for accessing concealed equipment and utility lines. Special offers for ceramic tiles.



**Plastic grilles for ventilation and air conditioning.  
(Catalogue no. 11)**

PROFIPLAST extruded plastic grilles for ventilation and air conditioning.

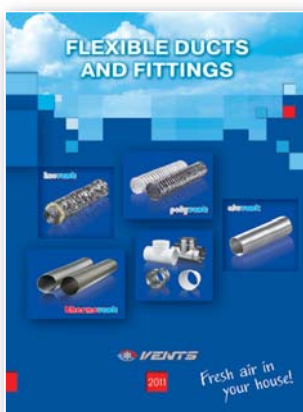

**Flexible ducts and fittings for ventilation, air conditioning and heating.  
(Catalogue no. 14)**

Flexible and semi-flexible air ducts made of polymeric materials, aluminium, galvanized or stainless steel, metal fittings for ventilation, air conditioning, heating, gas handling and abrasive substances aspiration.

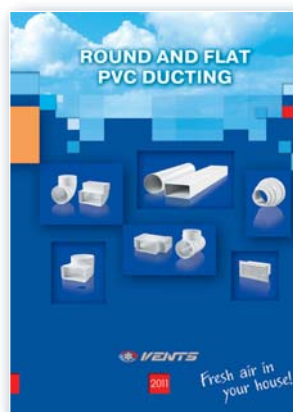

**Flat and round PVC air ducts  
(Catalogue no. 15)**

Flat and round PVC ducts PLASTIVENT for ventilation of residential, office and commercial premises and connection of exhaust ventilation equipment (kitchen extractors, hoods, exhaust boxes, etc). Wide product range of fittings.





## ■ WELCOME TO THE VENTS WORLD!

VENTS company was founded in the nineties of the XXth century.

Dynamic development of the enterprise and ongoing study of the consumer demand enabled rapid international leadership of the company in the ventilation industry.

VENTS company is one of few companies that manufacture independently a wide range of products for arrangement of ventilation systems of any complexity. The corporate affiliates are located worldwide and make the VENTS product easy available for the consumers all around the world.

VENTS is a powerful research and development enterprise with about 2000 professionals working as a single team to ensure a full production cycle from idea to end product. The production base of the company is located at more than 60 000 m<sup>2</sup> area. It includes 12 workshops equipped under the international standards and each of them is comparable to a separate plant.

Modern equipment, active implementation of advanced technologies and highly automated production are the characteristic features of VENTS company.

The company undergoes rapid dynamic development; fundamental researches and effective designs in climatic equipment industry are in the focus of the company's business strategy.

The joint cooperation of the corporate design department, test laboratories and production workshops let us introduce high quality products to the market.

Special attention is paid to the manufacturing of the goods during all manufacturing stages including monitoring of the technological conditions. Technical characteristics of supplied raw materials are thoroughly checked. Quality control system which meets international standard requirements ISO 9001:2000 was implemented at the enterprise.

Environmental protection is one of the basic components of the corporate development. The technological process at the enterprise is arranged in such a way as to exclude any negative impact to the environment. To solve the global energy saving problem we develop a special climatic equipment that provides comfortable conditions for people and reduces the energy demand significantly.



Metal workshop



Injection Molding workshop



Injection Molding workshop



Domestic fan workshop



Plastic grille workshop



Commercial fan workshop



Industrial fan workshop



Air handling units workshop



Spiral wound ducts workshop



Flexible Ducts workshop

VENTS is the only exporter of ventilation equipment in Ukraine. Our goods gained consumers' acceptance in more than 80 countries of the world including the countries of Europe, America, Asia that confirms the company reliability and top quality of our products. Since 2008 VENTS is the only Ukrainian member of the USA Ventilation and Conditioning Association HARDI. Worldwide recognition witnessed that VENTS is the leader of the world ventilation market.



**Get benefit from cooperation with VENTS TM and enjoy the maximum range of products of the top quality from one manufacturer.**



# VENTILATION IN OUR LIFE



## ▶ What is ventilation?

Ventilation means complex measures and facilities used for air exchange arrangement aimed to provide the required air condition in the premises and in working places. Ventilation systems maintain admissible meteorological parameters in various premises. Ventilation system should create such internal atmosphere that meets established hygienic standards and technological requirements.

## ▶ What Is Ventilation Required For?

We are surrounded with air and breathe in and out 20 000 litres of air every day. How much healthy is the air we breathe in? There is a range of aspects to evaluate air quality.

- ▶ **Oxygen and Carbon Dioxide Concentration in the Air.** Oxygen decrease and carbon dioxide increase cause stuffiness in the premises.
- ▶ **Harmful Substances and Dust in the Air.** High content of dust, tobacco smoke and other substances in the air are harmful for the human health and can cause various lung and skin diseases.
- ▶ **Smell.** Bad smell causes discomfort and makes us nervous.
- ▶ **Air Humidity.** High or low humidity causes discomfort and even may result in acute disease conditions. Air humidity is important also for the interior components. So, decreased humidity in winter can cause shrinkage and cracks in wooden doors, window frames, furniture and high humidity in swimming pools, bathrooms and other humid premises can cause excessive humidity absorption and swelling of the furniture.
- ▶ **Air temperature.** A person feels comfortable in a premise with the temperature 21-23°C. Lower or higher temperatures change the «comfort» well-being and influence a person's physical and mental activity.
- ▶ **Air Motion.** High air speed in the premises causes draft and low speed causes air blanketing. We are affected by any of these factors inside the room.

## ▶ Ventilation system arrangement

Properly arranged ventilation system is the only solution in this situation. It provides filtered air supply in summer and filtered and warmed supply air in winter as well as stale air removal from the premises.

Any ventilation system must include synchronous fresh air supply and extract air removal for the ideal air balance in the room. In case of no or insufficient fresh air supply the oxygen content decreases whereas humidity and dustiness increase. If exhaust ventilation is not provided or it is not effective the polluted air, smells, humidity and harmful substances are not removed.

Well coordinated functioning of supply and exhaust air vents is another important factor for a properly arranged ventilation system. In case of exhaust ventilation only (i.e. exhaust ventilation in the bathroom) air from outside flows through all possible gaps in windows, doors and walling. Such non-arranged air supply brings dust, smell and drafts.

Ventilation grilles installed in a bathroom door, wall or window vents, open windows or open window leaves serve as natural sources of supply ventilation and are used to compensate for air removal. However, forced mechanical ventilation with centralized air supply and distribution is much better solution!

## ▶ Calculation of the required air exchange.

### Engineering recommendations

#### Air exchange calculation according to the ventilation rate in the room.

Ventilated air amount is calculated on an individual basis for each premise with respect to harmful substances content or is determined by test results. If the nature and number of harmful impurities (substances) cannot be identified or measured air exchange is calculated with the formula:

$$L = V_{\text{area}} * K_{\text{exch}} \quad (\text{m}^3/\text{h}),$$

where  $V_{\text{area}}$  – ventilated area volume,  $\text{m}^3$ ;

$K_{\text{exch}}$  – minimum air exchange per hour, see air exchange table.

### How to calculate ventilated area volume?

Calculate the total volume of the premise in m<sup>3</sup>. Use a simple formula:

**length x width x height = volume of the premises m<sup>3</sup>**

$$A \times B \times H = V \text{ (m}^3\text{)}$$

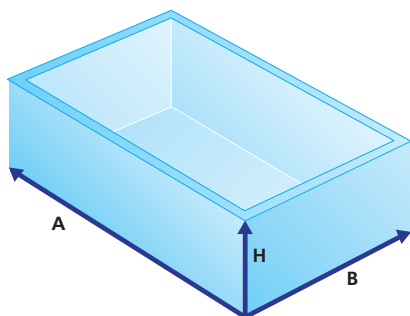

Example: premise with 7 m length, 4 m width and 2.8 m height. To determine the air volume required for ventilation of this premises, calculate the volume of the room: 7 x 4 x 2,8 = 78,4 m<sup>3</sup>. After that determine the required fan capacity using the following tables of recommended ventilation rate.

### Calculation of air exchange according to the number of people in the premises:

$$L = L_1 * N_1 \text{ (m}^3\text{/h)},$$

where  $L_1$  – rated value for air volume per one person, m<sup>3</sup>/hour\*person;

$N_1$  – number of people in a premise

20-25 m<sup>3</sup>/hour per one person at low physical activity

45 m<sup>3</sup>/hour per one person at light physical activity

60 m<sup>3</sup>/hour per one person at heavy physical activity

### Calculation of air exchange with moisture evaporation:

$$L = \frac{D}{(d_v - d_n) * \rho} \text{ (m}^3\text{/h)}$$

where  $D$  – moisture, g/hour;

$d_v$  – moisture content in the extract air, gram of water/kg of air;

$d_n$  – moisture content in the supply air, gram of water/kg of air;

$\rho$  – air density, kg/m<sup>3</sup> (at 20°C = 1,205 kg/m<sup>3</sup>);

### Calculation of air exchange to remove excessive heat:

$$L = \frac{Q}{\rho * C_p * (t_v - t_n)} \text{ (m}^3\text{/h)}$$

where  $Q$  – heat release in a premise, kW;

$t_v$  – extract air temperature, °C;

$t_n$  – supply air temperature, °C;

$\rho$  – air density [kg/m<sup>3</sup>] at 20°C = 1,205 kg/m<sup>3</sup>;

$C_p$  – heat capacity of air [kJ/(kg·K)] at 20°C;  $C_p = 1,005$  kJ/(kg·K)

### Air ventilation rate:

Premise	Air exchange rate	
Domestic premises	Living room (apartments or hostel)	3 m <sup>3</sup> /h for 1 m <sup>2</sup> in residential premises
	Kitchen in flat or hostel	6-8
	Bathroom	7-9
	Shower cabin	7-9
	WC	8-10
	Home laundry room	7
	Cloakroom	1,5
	Storeroom	1
	Garage	4-8
	Cellar	4-6
Industrial premises and large premises	Theatre, cinema, conference hall	20-40 m <sup>3</sup> per each visitor
	Office	5-7
	Bank	2-4
	Restaurant	8-10
	Bar, café, pub, billiard room	9-11
	Professional kitchen	10-15
	Supermarket	1,5-3
	Chemist's	3
	Garages and vehicle repair shop	6-8
	Public WC	10-12 (or 100 m <sup>3</sup> per each WC pan)
	Dance Halls and disco club	8-10
	Smoking room	10
	Server room	5-10
	Sport hall	80 m <sup>3</sup> or more for each sportsman and 20 m <sup>3</sup> or more for each viewer
	Hair dresser's	
	Up to 5 working places	2
	More than 5 working places	3
Warehouses	1-2	
Laundryroom	10-13	
Swimming pool	10-20	
Industrial painting shop	25-40	
Machine shop	3-5	
School classroom	3-8	

### Calculation of air exchange according to the threshold limit value of aggressive substances in the air:

$$L = \frac{G_{CO_2}}{y_{TLV} - y_c} \text{ (m}^3\text{/h)}$$

where  $G_{CO_2}$  – CO<sub>2</sub> release amount [l/hour];

$y_{TLV}$  – CO<sub>2</sub> maximum permissible concentration [l/m<sup>3</sup>];

$y_c$  – gas content in the supply air [l/hour].

**CO<sub>2</sub> permissible concentration norms, l/m<sup>3</sup>**

Permanently occupied residential premises	1,0	
Hospitals and child care centres	0,7	
Periodically occupied premises	1,25	
Periodically occupied non-residential premises	2,0	
Open air:	Populations centres (village)	0,33
	Small towns	0,4
	Big cities	0,5

**▶ What is pressure loss?**

Air resistance in ventilation system is mainly determined by air speed in this system. Resistance grows as the air speed increases. This phenomenon is called pressure loss. Static pressure produced by a fan causes air motion in the ventilation system with a certain resistance. The higher the resistance of such a system is, the less is the air capacity produced by the fan. Calculation of friction losses for air in air ducts, as well as resistance of the networking equipment (a filter, silencer, heater, valves and dampers, etc.) can be performed with help of tables and diagrams mentioned in the catalogue. The general pressure loss is equal to the total amount of all the resistance indices of all the elements in the ventilation system.

**Recommended air motion speed rate inside the air ducts:**

Type	Air speed, m/s
Main air ducts	6,0 - 8,0
Side branches	4,0 - 5,0
Air distribution ducts	1,5 - 2,0
Intake ceiling grilles	1,0 - 3,0
Extract grilles	1,5 - 3,0

**Calculation of air speed in the air ducts:**

$$V = \frac{L}{3600 \cdot F} \quad (\text{m/s})$$

where **L** – air capacity [ m<sup>3</sup>/hour];  
**F** – duct cross section [m<sup>2</sup>];

**Recommendation 1.**

Pressure loss in the duct system can be reduced due to larger duct section which provides relatively equal air speed in the whole system. The figure below shows how to provide relatively equal air speed in the duct system with the minimum pressure loss.

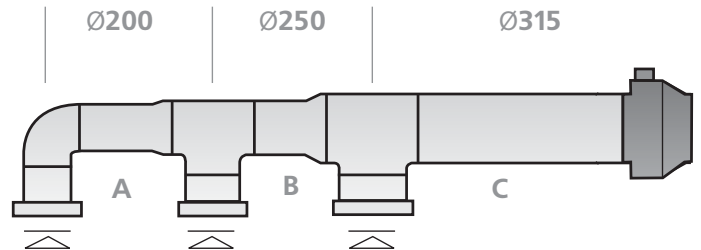

**Recommendation 2.**

The systems with large air duct length and large number of grilles should incorporate a fan in the middle of the ventilation system. Such solution has several advantages. On the one hand, pressure losses are reduced, on the other hand, smaller ducts are used.

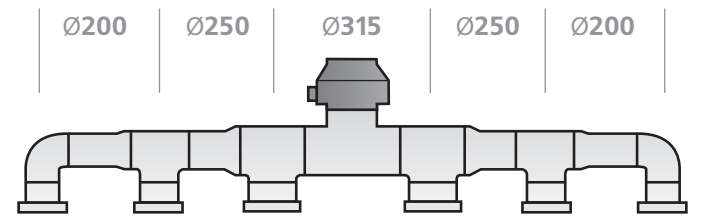

**Ventilation system calculation example:**

Start the calculation with the system drafting, showing the location of the air duct, ventilation grilles, fans and also the air duct section lengths between T-joint. Then calculate the air capacity at each section.

To calculate the pressure loss in the sections 1-6, use the pressure loss diagram for round air ducts. For that the required air duct diameters and pressure loss shall be determined under condition of permissible air speed in the duct.

**Section 1:** air capacity is 200 m<sup>3</sup>/h. On the assumption that the air duct diameter is 200 mm, air speed is 1.95 m/s the pressure loss makes 0.21 Poa/m x 15 m = 3 Pa (refer to the pressure loss diagram in the air ducts).

**Section 2:** the same calculations shall be performed considering that the air speed through this section makes 220 + 350 = 570 m<sup>3</sup>/h. On the assumption that the air duct diameter is 250 mm and the air speed is 3.23 m/s the pressure loss value makes 0.9 Pa/m x 20 m = 18 Pa.

**Section 3:** air capacity through this section makes 1070 m<sup>3</sup>/h. On the assumption that the air duct diameter is 315 mm and the air speed is 3.82 m/s the pressure loss value makes 1.1 Pa/m x 20 m = 22 Pa.

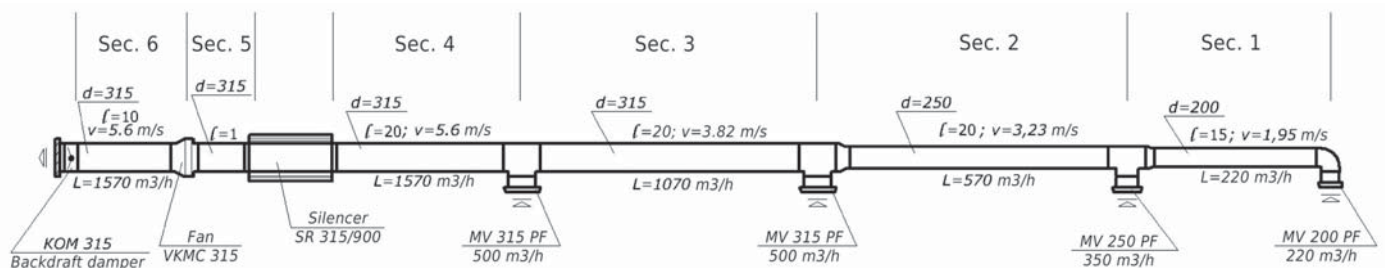

**Section 4:** air capacity through this section makes 1570 m<sup>3</sup>/h. On the assumption that the air duct diameter is 315 mm and the air speed is 5.6 m/s the pressure loss value makes 2.3 Pa/m x 20 m = 46 Pa.

**Section 5:** air capacity through this section makes 1570 m<sup>3</sup>/h. On the assumption that the air duct diameter is 315 mm and the air speed is 5.6 m/s the pressure loss value makes 2.3 Pa/m x 20 m = 2.3 Pa.

**Section 6:** air capacity through this section makes 1570 m<sup>3</sup>/h. On the assumption that the air duct diameter is 315 mm and the air speed is 5.6 m/s the pressure loss value makes 2.3 Pa x 10 m = 23 Pa.

The total pressure loss in the air duct makes 114.3 Pa.

As the last section pressure loss calculation is over calculate the pressure loss in the network elements as silencer SR 315/900 (16 Pa) and in the backdraft damper KOM 315 (22 Pa). Make also the calculation of the pressure loss in the tapping to the grilles. The total air resistance of 4 tappings makes 8 Pa.

**Pressure loss calculation at the duct bends**

The diagram allows calculating the pressure loss in the tapping on the basis of bend angle, air duct diameter and air capacity.

**Example.** Calculate the pressure loss for 90° bend, Ø 250 mm and air capacity 500 m<sup>3</sup>/h. For that find the intersection point of the vertical line that shows the air capacity with the vertical line. Find the pressure loss on the vertical line on the left for 90° pipe bend which makes 2 Pa.

We consider PF ceiling air diffusers and calculate their resistance according to the diagram which makes 26 Pa.

Now let us sum up all the pressure losses for the straight air duct section, network elements, bends and grilles. The ought quantity is 186.3 Pa.

We have calculated the whole system and have come to the conclusion that we need the exhaust fan to remove 1570 m<sup>3</sup>/h during the system resistance 186.3 Pa. Considering all the required operating characteristics VENTS VKMS 315 fan suits our requirements.

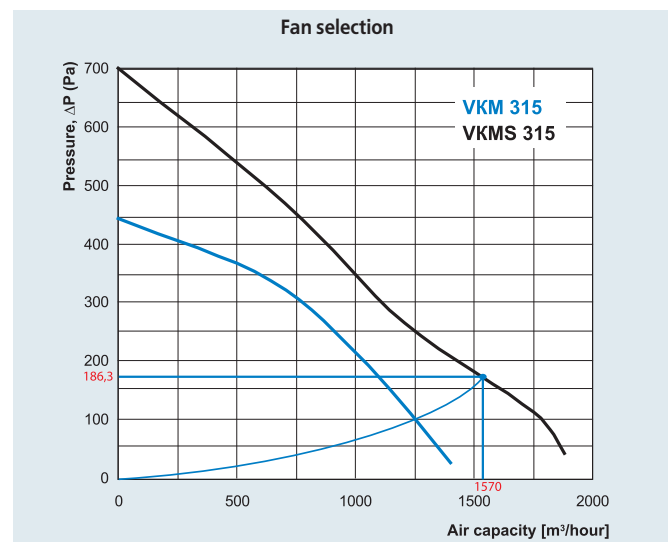
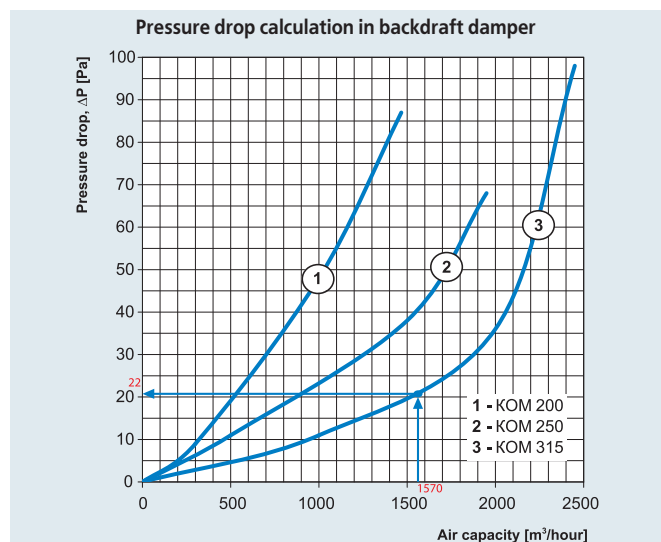
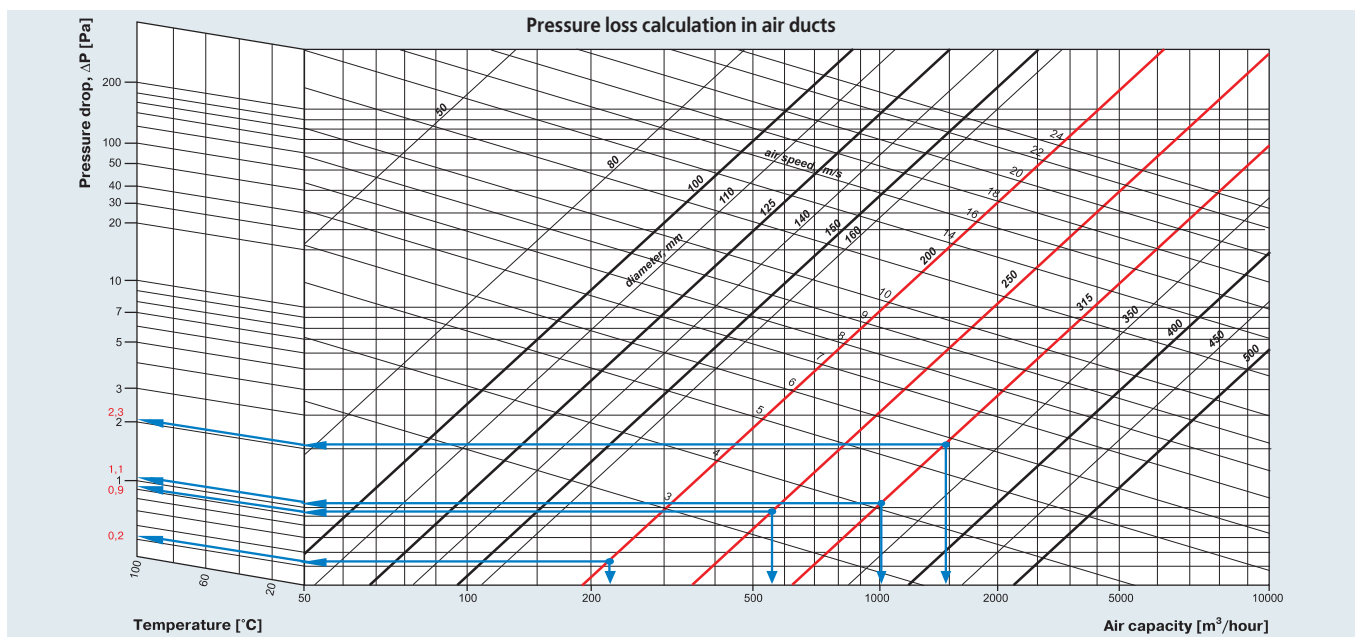



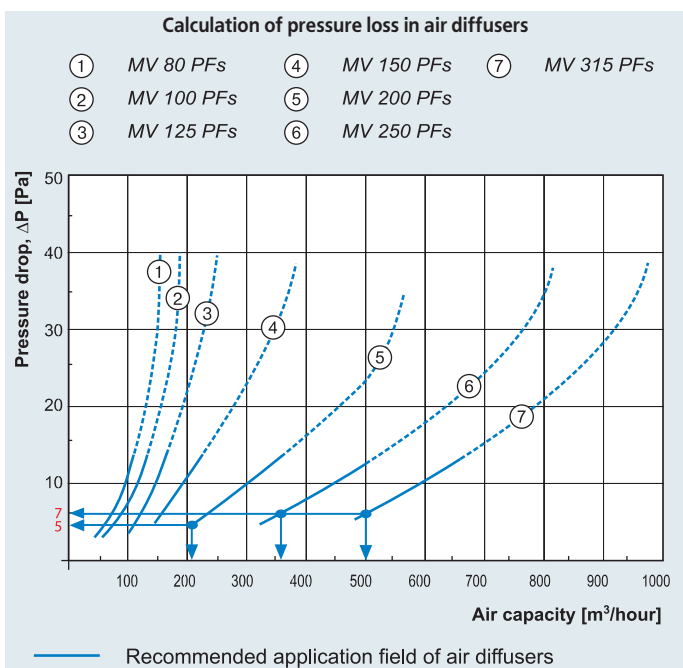
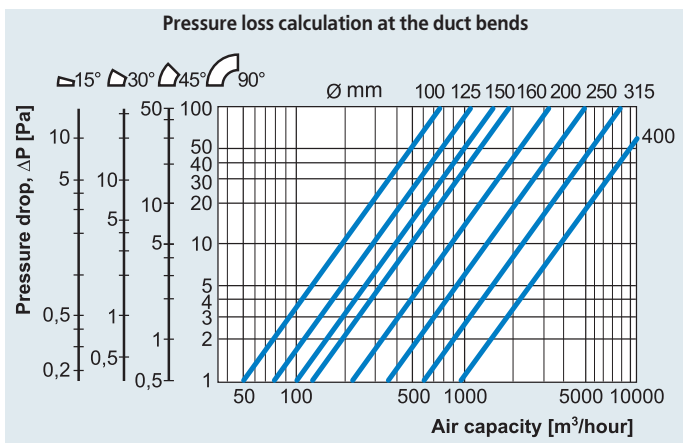
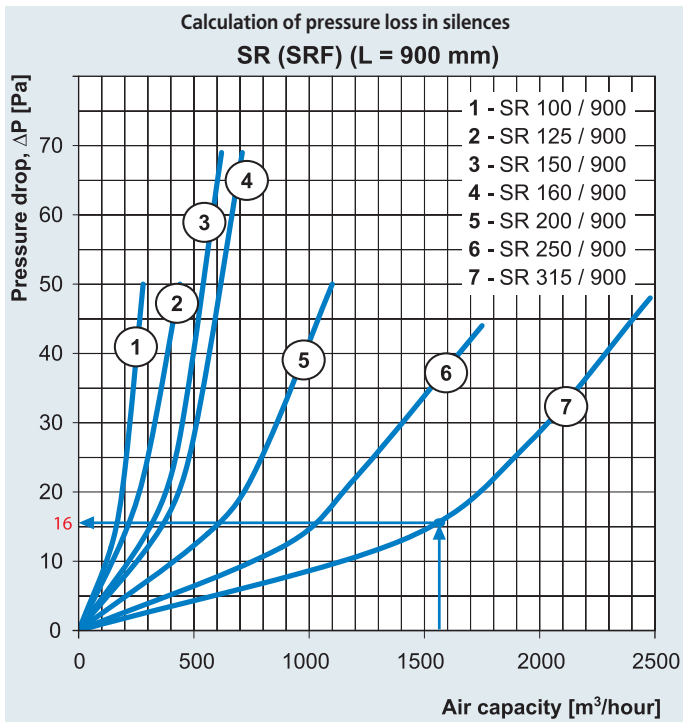

### What is a flexible air duct?

Flexible air ducts, Polyvent and Isovent series are the air ducts with a frame made of spiral wire reinforcement with elastic covering. Semi-flexible air ducts Aluvent and Thermovent are the spirally wound air ducts made of durable and less elastic materials.

The flexible and semi-flexible air duct design allows easy transportation to the site in compressed condition whereas during mounting the air ducts is stretched up to required length.



Due to many advantages flexible and semi-flexible air ducts gain more and more popularity.

### Basic advantages:

- Compact transportation;
- Low cost and easy weight of the system;
- Less time for mounting of the system;
- Quick system geometry amendment whenever required;
- Easy to use for dismantling, service and repair works;
- Cost reduction for the project.

### Air duct application

Flexible and semi-flexible air ducts are used for transportation of air masses in ventilation, air heating and conditioning systems and for the technological purposes as air supply to industrial units, technological waste aspiration and transportation of granular and granulated materials in pneumatic systems, etc.

The air ducts are installed in ventilation systems and vents of high-rise buildings, cottages and residential houses.

In commercial and industrial objects the air duct are used for air conditioning systems, air supply and exhaust systems, air heating systems.

A wide range of the VENTS air ducts offers the best suitable air duct type not only for ventilation, air conditioning and air heating systems but for specially designed industrial application:

- **Chemistry:** aggressive media transportation.
- **Pharmaceutics:** technological processes including pneumatic transportation.
- **Food and beverage:** transportation of food products and waste within permissible limits.
- **Car service centres, filling stations, oil refineries:** gas mixture exhaust.
- **Woodwork:** transportation of saw-dust and woodwork waste.
- **Glass industry:** aspiration of dust, glass and ceramic particles.

Use Tables 1 (pages 9–11), 2 and 3 (pages 40–41) to select air duct type.

## VENTS air duct design

The Polyvent and Isovent air ducts' frame is made of high-carbon steel spiral wire with 0.8-2 mm diameter that is covered by a film of various materials.

The spiral wire must have corrosion-resistant material and be thoroughly checked to ensure its durability and defeat resistance.

The distance between spiral turns is selected to ensure the air duct flexibility, to preserve its shape, comply with aerodynamic characteristics and to bear the construction load.

The Polyvent series air ducts are available in round and rectangular modifications and manifold standard sizes to meet all the mounting requirements.

The Aluvent and Thermovent air ducts are the spirally wound air ducts with a specially designed tight locks that provide impervious seam and complete air tightness.

The covering materials are selected to suit required applications and differ in thickness, durability and chemical composition. So the required air duct type is determined by a specific environment and purpose.

Semi-flexible air ducts have higher fire resistance rating: Aluvent series up to +250°C, Isovent series up to +800°C.

## Sound- and thermal insulation

Isovent series insulated air ducts are the flexible air ducts covered with mineral wool and outer sleeve. Such design meets the strictest sound- and thermal insulation requirements and prevents condensate generation, minimizes heat and cold losses, decreases noise level.

Mineral wool layer with 25 mm thickness is used for high operating conditions. This material is environmentally safe and has perfect insulating characteristics.

Depending on required insulation type the air ducts are available in two insulation modifications:

- ISO – thermal insulation;
- SONO – sound-insulation.

## Environmental protection

VENTS Company keeps a watchful eye on the ecological compatibility of the production process and applied materials. The use of the up-to-date technologies allows the VENTS air ducts comply with the highest ecology standards and be classified as non-toxic. These air ducts produce no harmful substances emission and not harmful.

## Fire resistance

Polyvent 605, Isovent 605, Polyvent 665 COMBY, Aluvent, Thermovent are used for objects with special fire-resistance requirements to air ducts.

Flexible air ducts Polyvent 605, Isovent 605, Polyvent 665 COMBY have M0 and M1 fire protection class according to European fire standards.

The air ducts are available on two modifications: M0 for short-time resistance up to +250°C for and M1 for short-time resistance up to +150°C.

**Table 1. Air ducts characteristics**

Series	Material	Temperature mode, °C	Aspiration of chemical vapours and aggressive substances	Aspiration of abrasive and powdered particles	Application
Polyvent 605 page 16	Flexible non-insulated aluminium foil air ducts with steel wire frame	-30 ... +250 (for M0) -30 ... +150 (for M1)	+	-	Residential and industrial ventilation, air conditioning and heating systems, peripheral sections of large central utility systems with the maximum pressure 3000 Pa and special fire-resistance requirements to air ducts (M0 or M1 models).
Isovent 605 page 17	Flexible aluminium foil heat-insulated air ducts ISO – sound-insulation; SONO – thermal insulation	-30 ... +250 (for M0) -30 ... +150 (for M1)	+	-	Residential and industrial ventilation, air conditioning and heating systems, peripheral sections of large central utility systems with the maximum pressure 3000 Pa and special fire-resistance requirements to air ducts (M0 or M1 models). Especially suitable for applications with requirements to thermal insulation (ISO series) or sound insulation (SONO series) to prevent condensate generation, heat and cold losses and noise level decrease.

**Table 1 (continued)**

Series	Material	Temperature mode, °C	Aspiration of chemical vapours and aggressive substances	Aspiration of abrasive and powdered particles	Application
Polyvent N page 18	Flexible non-insulated air ducts with steel wire frame covered with metalized polyester film (45 µm)	-30...+120	+	-	Residential and industrial ventilation, heating and air conditioning systems with no special requirements to the combustibility and temperature resistance, in heat accumulation units and peripheral sections of large central utility systems with the maximum pressure 3000 Pa.
Isovent N page 19	Flexible insulated air ducts with steel wire frame covered with metalized polyester film. (45 µm). ISO – sound-insulated; SONO – thermal-insulated	-30...+120	+	-	Residential and industrial ventilation, air conditioning and heating systems with special flammability and temperature resisting requirements, in particular for applications with the need of heat insulation combined with flexible air ducts to prevent condensate generation and heat and cold losses as well as in peripheral sections of large central utility systems with the maximum pressure 3000 Pa.
Polyvent 660 page 20	Flexible PVC film non-insulated air ducts with steel wire frame (65 µm)	-18...+70	-	-	Residential and commercial ventilation systems.
Polyvent 661 page 21	Flexible PVC film non-insulated air ducts with steel wire frame (110 µm)	-18...+70	-	-	Residential and commercial ventilation systems.
Polyvent 602 page 22	Flexible non-insulated PVC film air ducts with steel wire frame (190 µm)	-18...+80	-	-	Commercial and industrial ventilation systems operating in heavy-duty mode.
Polyvent 606 page 23	Flexible non-insulated PVC film air ducts with steel wire frame (250 µm)	-18...+90	-	+	Residential, commercial and industrial ventilation and air conditioning systems operating in heavy-duty mode for humid air removal, removal of smoke, postwelding gases, powdered solid particles, waste chips, fibres, vapours, soot and low-abrasive materials.
Polyvent 607 page 24	Flexible non-insulated PVC film air ducts with steel wire frame (700 µm)	-18...+90	+	+	Industrial ventilation systems operating in heavy-duty mode for humid air removal, removal of smoke, postwelding gases, powdered solid particles, waste chips, fibres, vapours, soot and abrasive materials.
Polyvent 600 page 25	Flexible non-insulated PVC film air ducts with steel wire frame (250 µm)	-21...+110	+	+	Industrial ventilation systems operating in heavy-duty mode, incl. agricultural and pharmaceutical applications for aspiration of granulated material, removal of chemical vapours, smoke, postwelding gases, powdered solid particles, waste chips, fibres, vapours, soot and low-abrasive dust and in environment with special temperature resistance requirements (up to +110 °C).



**Table 1 (continued)**

Series	Material	Temperature mode, °C	Aspiration of chemical vapours and aggressive substances	Aspiration of abrasive and powdered particles	Application
Polyvent 601 page 26	Flexible non-insulated PVC film air ducts with steel wire frame (250 µm)	-21...+110	+	+	Industrial ventilation systems operating in heavy-duty mode, incl. agricultural and pharmaceutical applications for aspiration of granular and granulated material, removal of chemical vapours, smoke, postwelding gases, powdered solid particles, waste chips, fibres, vapours, soot and low-abrasive dust and in environment with special temperature resistance requirements (up to +110 °C).
Polyvent 620 page 27	Flexible polyurethane non-insulated air ducts with steel wire frame (250 µm)	-21...+110	+	+	Industrial ventilation systems, the ideal solution for application in woodwork and timber industry, car service and fuel stations, oil refineries. Used for removal of gas mixture with high abrasive dust content. Suitable for outside installation.
Polyvent 621 page 28	Flexible polyurethane non-insulated air ducts with steel wire frame (450 µm)	-21...+110	+	+	Industrial ventilation systems, the ideal solution for application in woodwork and timber industry, car service and fuel stations, oil refineries. Used for removal of gas mixture with high abrasive dust content. Suitable for outside installation.
Polyvent 615 page 29	Flexible polyurethane non-insulated air ducts with steel wire frame (75 and 150 µm)	-18...+70	-	-	Residential ventilation systems. Recommended for ventilation of child care centres, educational and medial facilities, spa resorts.
Polyvent 665 Comby page 30	Flexible non-insulated air ducts with steel wire frame covered with aluminium foil and polyether	-30 ... +250 (for M0) -30 ... +150 (for M1)	+	-	Residential ventilation and air conditioning systems of living quarters, administrative and public premises.
Aluvent page 34	Semi-flexible aluminium air ducts (50 µm, 80 µm, 100 µm)	-30...+ 250	+	+	Residential and industrial ventilation, air conditioning and heating systems with the maximum pressure 10 000 Pa.
Thermovent page 35	Semi-flexible galvanized or stainless steel air ducts (80 µm, 100 µm)	-30...+700	+	+	Residential and industrial ventilation, air conditioning and heating systems with the maximum pressure 10 000 Pa for hot air removal from boiler houses and smoke exhaust systems.
Thermovent Aero page 36	Stainless steel air ducts with high temperature resistance (100 µm)	-30...+800	+	+	Residential and industrial ventilation, air conditioning and heating systems with the maximum pressure 10 000 Pa for hot air removal from boiler houses and smoke exhaust systems.
Thermovent Flex page 37	Semi-flexible corrugated stainless steel air ducts with high temperature resistance (100 µm)	-30...+800	+	+	Residential and industrial ventilation, air conditioning and heating systems with the maximum pressure 10 000 Pa for hot air removal from boiler houses and smoke exhaust systems.
Thermovent Aero Flex page 38	Double-layer stainless steel air ducts with smooth internal surface and corrugated external layer	-30...+800	+	+	Residential and industrial ventilation, air conditioning and heating systems with the maximum pressure 10 000 Pa for hot air removal from boiler houses and smoke exhaust systems.

## Air duct mounting

Correct air duct connection is of significant importance to ensure reliable operation and aerodynamic characteristics of mounted air ducts.

Flexible air ducts are connected to basic ventilation system components by various fittings or connected directly to final components as ventilation grilles, disk valves and fans.

A wide range of VENTS fittings is designed to consider variety of manifold air duct connections and facilitate mounting works a lot.

## Tools and materials for air duct mounting

- Construction meter
- Marker
- Cutting knife
- Flat-nose pliers or cutting pliers
- Gloves (for work with insulated air ducts)
- Cross-point screwdriver for clamp fixing
- Mounting tape
- Fixing clamps

## General rules

- Mounted air duct must be stretched to the maximum to avoid pressure loss
- Air duct must not be deflected and sagged.
- Keep bend radius as large as possible because the minimum air bend increases pressure drop. To level up this effect the bend radius must be equal to the double air duct diameter.
- Provide grounding during mounting operations as static electricity can be accumulated during transportation of air containing organic solvents along the air ducts.
- Air flow in the air duct must have spiral motion.
- Use metal connectors or reducers in case of layout through wall constructions.
- Take precautions not to deform or damage air duct during mounting.

**Warning!** To avoid deformation stretch Aluvent air ducts gradually from the middle to the ends.



## Air duct cutting

- Calculate the air duct length in such a way as to omit any sagging as mounted.
- Stretch the air duct to its maximum.
- Measure the required length and mark it.
- For non-insulated air ducts: cut air duct along a spiral turn with a sharp knife or scissors and cut the wire with cutting pliers.
- For insulated air ducts: first cut the outer sleeve with scissors. Use gloves for that.

## Connection to final component

- Connect the air duct to the ventilation grille flange or fan branch pipe with respect to the spiral air motion.
- Fix it with clamps. Use respective diameter clamps. Make sure that the air duct is not deformed in the attaching points.

## Mounting with fittings

- Connect the air duct to a fitting by spiral turns, the branch pipe length for connection to the air duct must be at least 50 mm. Seal the joint with a mounting tape if required.
- Fix it with a fixing clamp.

## Mounting of non-insulated air ducts

- Cover the branch pipe with the air duct at least by 50 mm by spiral turns over the air duct. Seal the joint with a mounting tape if required.
- Fix the air duct with a fixing clamp.



### Mounting of insulated air duct

- ① Cover the branch pipe with the air duct at least by 50 mm by spiral turnings over the air duct.
  - ② Pull off the insulation material. Seal the joint with a mounting tape if required.
  - ③ Fix the air duct with a fixing clamp.
  - ④ Pull away the insulation material.
- Fix the outer shell with a mounting tape by wrapping it twice around the air duct.

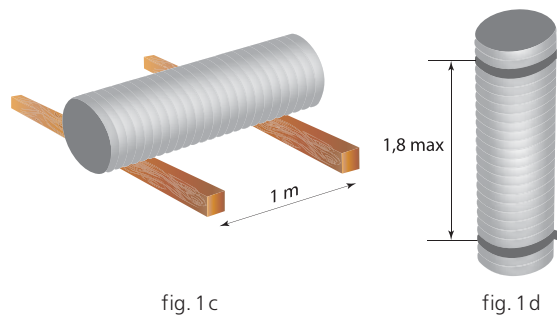
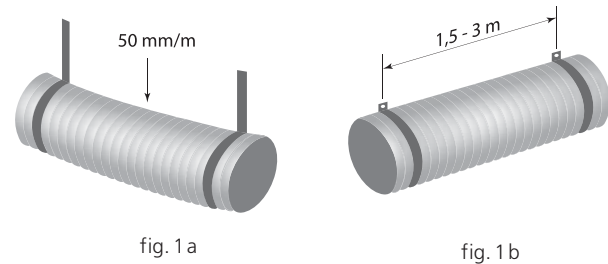

### Air duct application and use recommendations

- Flexible air ducts are not recommended for use in vertical shafts above 2 floors high.
- In case of application of the flexible air duct in high temperature operating conditions make sure that the air duct temperature resistance is suitable for the specific operating conditions.
- During installation in fireproof constructions of the floors/ceilings the air ducts must comply with fire safety requirements.
- Flexible air ducts are not suitable for routing through the floor or below ground. Contact with ground is not allowed.
- Use only specially designed air ducts for external mounting.
- Air ducts must be mounted far away enough from the places with excessive heat generation.
- Application scope of flexible air ducts can be limited by national norms and standards. Read information on air duct application and technical data before using the air ducts!

### Suspension points

- Maximum sagging of the air duct between two suspension points must not exceed 50 mm/m (fig. 1 a).
- Distance between two suspension points ranges between 1.5 to 3 m depending on the air duct type (fig. 1 b).
- Effective span distance for the flexible air duct must be 1 meter (fig. 1 c).
- In case of vertical air duct layout the distance between the fixing clamps shall be from 1 m to 1.8 m (fig. 1 d).



# FLEXIBLE AIR DUCTS FOR VENTILATION AND AIR CONDITIONING



## **Non-insulated air ducts Polyvent 605 series**

Aluminium foil

page  
16



## **Insulated air ducts Isovent 605 series**

Aluminium foil

page  
17



## **Non-insulated air ducts Polyvent N series**

metalized foil

page  
18



## **Insulated air ducts Isovent N**

metalized foil

page  
19



## **Non-insulated air ducts Polyvent 660 series**

polyvinylchloride [65 µm]

page  
20



## **Non-insulated air ducts Polyvent 661 series**

polyvinylchloride [110 µm]

page  
21



## **Non-insulated air ducts Polyvent 602 series**

polyvinylchloride [190 µm]

page  
22



## **Non-insulated air ducts Polyvent 606 series**

polyvinylchloride [250 µm]

page  
23

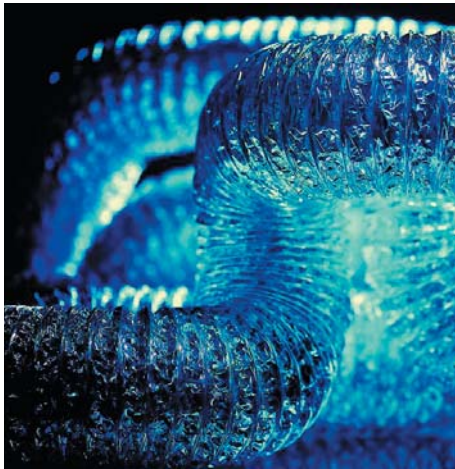

**Non-insulated air ducts  
Polyvent 607 series**

polyvinylchloride [700 µm]

page  
24



**Non-insulated air ducts  
Polyvent 600 series**

polyether fiber covered with polyvinylchloride [250 µm]

page  
25



**Non-insulated air ducts  
Polyvent 620 series**

custom-designed polyurethane [250 µm]

page  
27



**Non-insulated air ducts  
Polyvent 621 series**

specially designed polyurethane [450 µm]

page  
28



**Non-insulated air ducts  
Polyvent 615 series**

polyethylene [75 µm / 150 µm]

page  
29



**Non-insulated air ducts  
Polyvent 665 Comby series**

Aluminium foil and PVC

page  
30





**Isovent 605 series**



**605-ISO-M0**  
**605-ISO-M1**

Flexible aluminium foil heat-insulated air ducts



**6051-SONO-M0**  
**6051-SONO-M1**

Flexible heat- and sound-insulated aluminium foil air ducts

**Description**

- Flexible heat-insulated (ISO) and insulated-absorbing (SONO) air duct.
- Spiral frame from high-carbon steel wire.

**Features**

- Pollution-free, no harmful substances emission during operation.
- No chlorine and cadmium content.
- High elasticity and temperature resistance: short-time resistance up to +250°C for M0, short-time resistance up to +150°C for M1.
- High rupture and mechanical resisting features.

**Recommended application**

- Applied in residential and industrial ventilation, air conditioning and heating systems, peripheral sections of large central utility systems with the maximum pressure 3000 Pa and special fire-resistance requirements to air ducts (M0 or M1 models).
- Especially suitable for applications with requirements to thermal insulation (ISO series) or sound insulation (SONO series) to prevent condensate generation, heat and cold losses and noise level decrease.
- Recommended for ventilation of child care centres, educational and medical facilities, spa resorts.

**Technical data**

Item	605-ISO-M0 605-ISO-M1	6051-SONO-M0 6051-SONO-M1
Range of sizes [mm]	Ø 102; 127; 152; 182; 203; 254; 315	
Air duct base	Aluminium foil laminated with polyester film	microperforated aluminium band laminated with polyester film
Air duct wire	steel spring, 0.8-1.5 mm thick	
Insulation	mineral wool, 25 mm	
Outer sleeve	Aluminium foil laminated with polyester film	
Safety class	incombustible (for M0 model), self-extinguishing (for M1 model)	
Operating temperature range [°C]	-30 ... +250 (for M0 model), -30 ... +150 (for M1 model)	
Standard length [m]	10	
Available lengths (cutting) [m]	7,6; 10	
Air speed [m/s]	30	
Maximum operating pressure [Pa]	3000	

**Colour range**



Aluminium  
(\_)



Brown  
(B)

**Packing**



Cardboard box

**Order code**

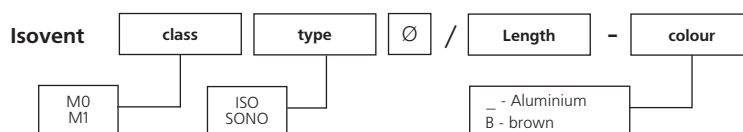

**Accessories**



## Polyvent N series



Flexible non-insulated air ducts with steel wire frame covered with metalized polyester film

### Description

- Flexible air duct from metalized polyester film.
- Spiral frame from high-carbon steel wire.

### Features

- Pollution-free flexible non-insulated air duct. No harmful substances emission during operation.
- high elasticity and temperature resistance: short-time resistance up to +120°C.

### Recommended application

- Applied in residential and industrial ventilation, heating and air conditioning systems with no special requirements to the combustibility and temperature resistance, in heat accumulation units and peripheral sections of large central utility systems with the maximum pressure 3000 Pa.
- Recommended for ventilation of child care centres, educational and medial facilities, spa resorts.

### Technical data

Item	Polyvent N
Range of sizes [mm]	Ø 82; 102; 127; 152; 182; 203; 254; 315; ...630
Air duct base	metalized polyester film (45 µm)
Air duct wire	steel spring, 0.8-1.5 mm thick
Operating temperature range [°C]	-30...+120
Standard length [m]	1; 1,5; 3; 7,6
Available lengths (cutting) [m]	1; 1,5; 3; 7,6
Air speed [m/s]	30
Maximum operating pressure [Pa]	3000

### Colour range



Aluminium  
(\_)

### Packing



Cardboard box

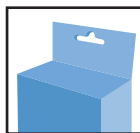

Unit coloured packing

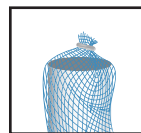

Net

### Order code

Polyvent N  /

### Accessories



## Isovent N series



Flexible insulated air ducts with steel wire frame covered with metalized polyester film

### Description

- Flexible insulated air duct from metalized polyether film.
- Spiral frame from high-carbon steel wire.

### Features

- Pollution-free flexible air duct insulated with mineral wool layer.
- No harmful products emission during operation.
- No chlorine and cadmium content.
- High elasticity and temperature resistance: short-time resistance up to +120°C.

### Recommended application

- Applied in residential and industrial ventilation, air conditioning and heating systems with special flammability and temperature resisting requirements, in particular for applications with the need of heat insulation combined with flexible air ducts to prevent condensate generation and heat and cold losses as well as in peripheral sections of large central utility systems with the maximum pressure 3000 Pa.
- Recommended for ventilation of child care centres, educational and medial facilities, spa resorts.

### Technical data

Item	Isovent N
Range of sizes [mm]	Ø 82 102; 127; 152; 182; 203; 254; 315; ...630
Air duct base	metalized polyester film (45 µm)
Air duct wire	steel spring, 0.8-1.5 mm thick
Insulation	Mineral wool, 25 mm
Outer sleeve	metalized polyester film (45 µm)
Operating temperature range [°C]	-30...+120
Standard length [m]	7,6
Available lengths (cutting) [m]	7,6
Air speed [m/s]	30
Maximum operating pressure [Pa]	3000

### Colour range



Aluminium  
(\_)

### Packing



Cardboard  
box

### Order code

Isovent N  /

### Accessories





## Polyvent 660 series



660



6601

Flexible PVC film non-insulated air ducts with steel wire frame (65 µm)

### Description

- Flexible PVC air duct with spiral high-carbon steel wire frame.

### Features

- High compression ratio.
- Heavy-flammable, flame-retarding, self-extinguishing.

### Recommended application

- Applied in residential and commercial ventilation systems.
- The ideal solution for ventilation of living quarters and office premises.

### Technical data

Item	660	6601
Range of sizes [mm]	Ø 102; 127; 152	110x55; 60x204
Air duct base	PVC film (65 µm)	
Air duct wire	steel spring, 0.8 mm thick	
Operating temperature range [°C]	-18...+70	
Standard length [m]	1; 1,5; 3; 6	1; 1,5; 3; 6
Available lengths (cutting) [m]	1; 1,5; 2,5; 3; 6; 15; 45	1; 1,5; 3; 6
Air speed [m/s]	30	
Maximum operating pressure [Pa]	3000	

### Colour range



White  
(\_)

### Packing



Cardboard box

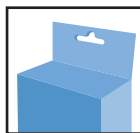

Unit coloured packing

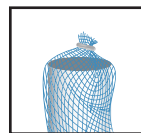

Net

### Order code

Polyvent   /

### Accessories



## Polyvent 661 series



Flexible PVC film non-insulated air ducts with steel wire frame (110 µm)

### Description

- Flexible PVC air duct with spiral high-carbon steel wire frame.

### Features

- Low pressure loss due to increased wall rigidity.
- Long service life.
- Heavy-flammable, flame-retarding, self-extinguishing.

### Recommended application

- Applied in residential and commercial ventilation systems.
- Recommended for use in office premises, trade and recreational buildings, etc.

### Technical data

Item	Polyvent 661
Range of sizes [mm]	Ø 102; 127; 152
Air duct base	PVC film (110 µm)
Air duct wire	steel spring, 0.8 mm thick
Operating temperature range [°C]	-18...+70
Standard length [m]	6
Available lengths (cutting) [m]	6
Air speed [m/s]	30
Maximum operating pressure [Pa]	3000

### Colour range



White  
(\_)

### Packing



Cardboard box

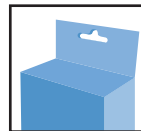

Unit coloured packing

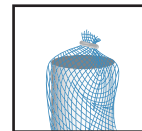

Net

### Order code

Polyvent 661



/

length

### Accessories



## Polyvent 602 series

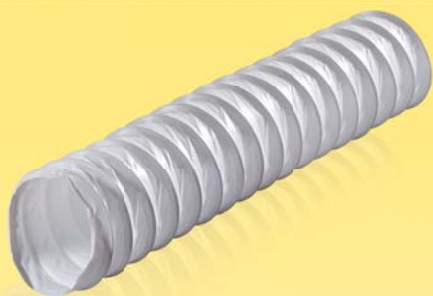

Flexible non-insulated PVC film air ducts with steel wire frame (190 µm)

### Description

- Flexible PVC air duct with spiral high-carbon steel wire frame.

### Features

- Low pressure loss due to extremely high wall rigidity.
- Long service life.
- Heavy-flammable, flame-retarding, self-extinguishing.

### Recommended application

- Applied in commercial and industrial ventilation systems operating in heavy-duty mode.

### Technical data

Item	Polyvent 602
Range of sizes [mm]	Ø 102; 127; 152
Air duct base	PVC film (190 µm)
Air duct wire	steel spring, 0.8 mm thick
Operating temperature range [°C]	-18...+80
Standard length [m]	6
Available lengths (cutting) [m]	6
Air speed [m/s]	30
Maximum operating pressure [Pa]	3000

### Colour range



White  
(\_)

### Packing



Cardboard box

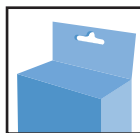

Unit coloured packing

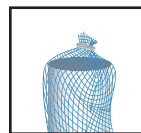

Net

### Order code

Polyvent 602



/

length

### Accessories







## Polyvent 607 series



Flexible non-insulated PVC film air ducts with steel wire frame (700 µm)

### Description

- Flexible PVC air duct with spiral high-carbon steel wire frame.

### Features

- Low pressure loss due to extremely high wall rigidity.
- The service life is equal to that one of the galvanized air ducts.

- High abrasion resistance.
- Heavy-flammable, flame-retarding, self-extinguishing.

### Recommended application

- Applied in industrial ventilation systems operating in heavy-duty mode.
- Humid air removal, removal of smoke, post-welding gases, powdered solid particles, waste chips, fibres, vapours, soot and low-abrasive materials.

### Technical data

Item	607
Range of sizes [mm]	Ø 82; 102; 120; 127; 152; 160; 182; 203; 254
Air duct base	PVC film (700 µm)
Air duct wire	steel spring, 1.5 mm thick
Operating temperature range [°C]	-18...+90
Standard length [m]	6
Available lengths (cutting) [m]	6
Air speed [m/s]	30
Maximum operating pressure [Pa]	3000

### Colour range



Grey  
(\_)

### Packing



Cardboard box

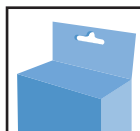

Unit coloured packing

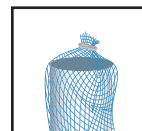

Net

### Order code

Polyvent 607



/

length

### Accessories



Diffusers and air disk valves

Grilles and hoods

Backdraft dampers

Fittings

Clamps

## Polyvent 600 series



Flexible non-insulated PVC film air ducts with steel wire frame (250 µm)

### Description

- Flexible air duct from polyester PVC impregnated fiber and spiral high-carbon steel wire frame.

### Features

- Low pressure loss due to high wall rigidity.
- High mechanical and abrasion resistance.
- High chemical stability, high temperature resistance (up to +110 °C).

### Recommended application

- Applied in industrial ventilation systems operating in heavy-duty mode, incl. agricultural and pharmaceutical applications.
- Handling of granular and granulated material, removal of chemical vapours, smoke, postwelding gases, powdered solid particles, waste chips, fibres, vapours, soot and low-abrasive dust and in environment with special temperature resistance requirements (up to +110 °C).

### Technical data

Item	Polyvent 600
Range of sizes [mm]	Ø 51; 54; 61; 71; 76; 82; 102; 114; 121; 127; 133; 140; 152; 165; 182; 203; 228; 254; 279; 304; 330; 355; 381; 404; 457; 508; 59; 610; 635; 650; 711; 750; 813; 838; 864; 889; 915; 995
Air duct base	polyester fiber covered with PVC (250 µm)
Air duct wire	steel spring, 0.8-2 mm thick
Operating temperature range [°C]	-21...+110
Standard length [m]	6
Available lengths (cutting) [m]	6
Air speed [m/s]	30
Maximum operating pressure [Pa]	3000

### Colour range



White  
(\_)



Grey  
(G)



Brown  
(B)

### Packing



Cardboard box

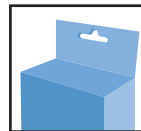

Unit coloured packing

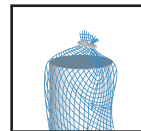

Net

### Order code

Polyvent 600    Ø /    length    -    colour

\_ - white  
G - grey  
B - brown

### Accessories





## Polyvent 601 series



Flexible non-insulated PVC film air ducts with steel wire frame (250 µm)

### Description

- Flexible air duct from polyester PVC impregnated fiber and spiral high-carbon steel wire frame.

### Features

- Low pressure loss due to high wall rigidity.
- High mechanical and abrasion resistance.
- High chemical stability, high temperature resistance (up to +110 °C).

### Recommended application

- Applied in industrial ventilation systems operating in heavy-duty mode, incl. agricultural and pharmaceutical applications.
- Handling of granular and granulated material, removal of chemical vapours, smoke, post-welding gases, powdered solid particles, waste chips, fibres, vapours, soot and low-abrasive dust and in environment with special temperature resistance requirements (up to +110 °C).

### Technical data

Item	Polyvent 600
Range of sizes [mm]	65x145; 65x185; 80x200; 55x110, 70x150, 80x158, 58x230, 54x222, 82x222, 90x220, 80x230, 116x224
Air duct base	polyester fiber covered with PVC (250 µm)
Air duct wire	steel spring, 0.8-2 mm thick
Operating temperature range [°C]	-21...+110
Standard length [m]	6
Available lengths (cutting) [m]	6
Air speed [m/s]	30
Maximum operating pressure [Pa]	3000

### Colour range



White  
(\_)



Grey  
(G)



Brown  
(B)

### Packing



Cardboard box

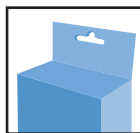

Unit coloured packing

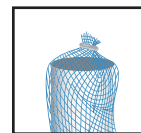

Net

### Order code

**Polyvent 601**     /  -

- white  
 G - grey  
 B - brown

### Accessories



## Polyvent 620 series



620



6201

Flexible polyurethane non-insulated air ducts with steel wire frame (250 µm)

### Description

- Flexible polyurethane air duct with high-carbon steel wire frame.

### Features

- Extremely high wear resistance, durability, air tightness, low pressure losses.
- Heavy-flammable. The ideal solution for application in woodwork and timber industry and for removal of air mixtures with high

abrasive dust content. High resistance to solvent-, gasoline- and oil vapours.

- UV- and ozone resistance. Suitable for handling of hot gases (up to +120 °C).

### Recommended application

- Applied in industrial ventilation systems, the ideal solution for application in woodwork and timber industry, car service and fuel stations, oil refineries. Used for removal of gas mixture with high abrasive dust content. Suitable for outside installation.

### Technical data

Item	620	6201
Range of sizes [mm]	Ø 51; 54; 61; 71; 76; 82; 89; 102; 121; 127; 152; 165; 182; 203; 228; 254; 304; 381; 404; 508; 635; 711	224x116, 230x80, 220x90, 222x54, 230x58, 150x80, 150x70, 110x54, 145x65
Air duct base	Specially designed polyurethane film (250 µm)	
Air duct wire	steel spring, 0.8-2 mm thick	
Operating temperature range [°C]	-21...+110	
Standard length [m]	6	
Available lengths (cutting) [m]	6	
Air speed [m/s]	30	
Maximum operating pressure [Pa]	3000	

### Colour range



Transparent ( )

### Packing



Cardboard box

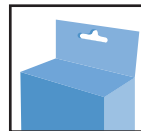

Unit coloured packing

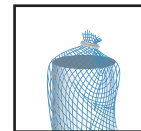

Net

### Order code

Polyvent   /

### Accessories



## Polyvent 621 series



Flexible polyurethane non-insulated air ducts with steel wire frame (450 µm)

### Description

- Flexible polyurethane air duct with high-carbon steel wire frame.

### Features

- High flexibility, wear resistance, durability, air tightness, extremely low pressure losses.
- Heavy flammable.
- High solvent-, gasoline- and oil vapours resistance.

- UV- and ozone resistance.
- Hot gases handling is possible (up to +120°C).

### Recommended application

- Applied in industrial ventilation systems, the ideal solution for application in woodwork and timber industry, car service and fuel stations, oil refineries. Used for removal of gas mixture with high abrasive dust content. Suitable for outside installation.

### Technical data

Item	Polyvent 621
Range of sizes [mm]	Ø 51; 54; 61; 71; 76; 82; 89; 102; 114; ; 121; 127; 133; 140; 152; 165; 182; 203; 228; 254; 29; 304; 330; 355; 381; 404; 457; 508
Air duct base	Specially designed polyurethane film (450 µm)
Air duct wire	spring steel 0.8-2 mm thick
Operating temperature range [°C]	-21...+110
Standard length [m]	6
Available lengths (cutting) [m]	6
Air speed [m/s]	30
Maximum operating pressure [Pa]	3000

### Colour range



Transparent ( )

### Packing



Cardboard box

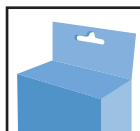

Unit coloured packing

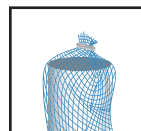

Net

### Order code

Polyvent 621



/

length

### Accessories





## Polyvent 615 series



615



6150

Flexible polyurethane non-insulated air ducts with steel wire frame (75 and 150 µm)

### Description

• Flexible air duct from polyethylene with high-carbon steel wire frame.

### Features

- Pollution-free, no harmful substances emission during operation.
- Contents no chlorine and cadmium.

### Recommended application

- Applied in residential ventilation systems.
- Recommended for ventilation of child care centres, educational and medial facilities, spa resorts.

### Technical data

Item	615	6150
Range of sizes [mm]	Ø 82; 102; 127; 152; 182	55x110; 70x150; 80x150; 54x222
Air duct base	Polyethylene film (75 µm)	Polyethylene film (150 µm)
Air duct wire	steel spring, 0.8 mm thick	
Operating temperature range [°C]	-18...+70	
Standard length [m]	6	
Available lengths (cutting) [m]	6	
Air speed [m/s]	30	
Maximum operating pressure [Pa]	3000	

### Colour range



White  
(\_)

### Packing



Cardboard box

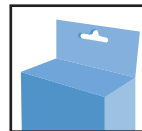

Unit coloured packing

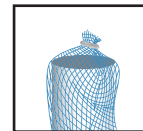

Net

### Order code

Polyvent   /

### Accessories



## Polyvent 665 Comby series



Flexible non-insulated air ducts with steel wire frame covered with aluminium foil and polyether

### Description

- Flexible heavy-duty air duct from multilayer aluminium foil, polyether and PVC with high-carbon steel wire frame.

### Features

Versus PVC foil air ducts:

- High temperature resistance;
- non-flammable internal layer, fire safety class M0 (up to 250 °C) or M1 (up to 150 °C).

Versus aluminium foil air ducts:

- High rupture resistance;
- better protection against outside mechanical impact;
- airtight, expansion- and deformation resistant.

### Recommended application

- Applied in residential ventilation and air conditioning systems of living quarters, administrative and public premises.

### Technical data

Item	Polyvent 665 Comby
Range of sizes [mm]	Ø 102,127; 152;
Air duct, internal layer	Aluminium foil laminated with polyester film
Air duct, external layer	PVC
Air duct wire	steel spring, 0.8-2 mm thick
Operating temperature range [°C]	-30 ... +250 (for M0), -30 ... +150 (for M1)
Standard length [m]	1; 1,5; 2; 2,5; 3; 6; 10
Available lengths (cutting) [m]	1; 1,5; 2; 2,5; 3; 6; 10
Air speed [m/s]	30
Maximum operating pressure [Pa]	3000

### Colour range



White  
(\_)

### Packing



Cardboard box

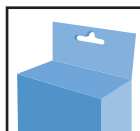

Unit coloured packing

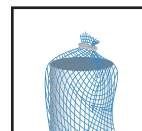

Net

### Order code

Polyvent 665 - Comby

fire safety class	Ø	/	length
M0 M1			

### Accessories



### Pressure loss diagram per 1 m stretched air duct

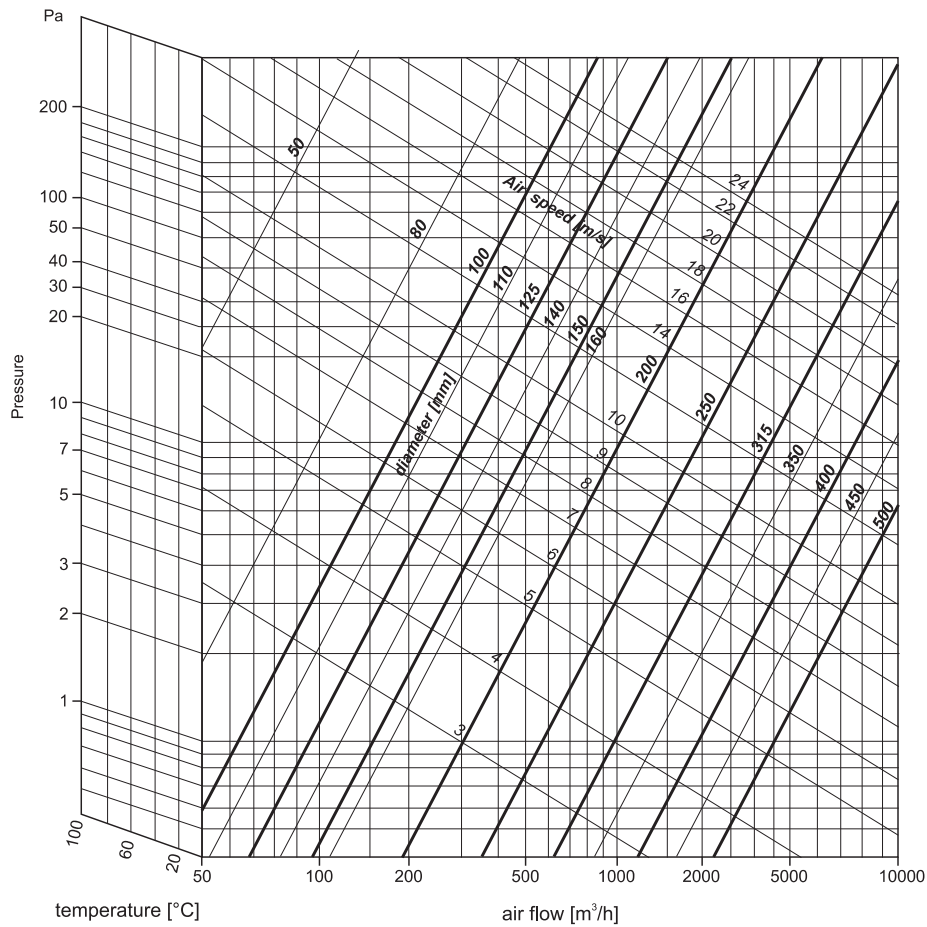

### Calculation example

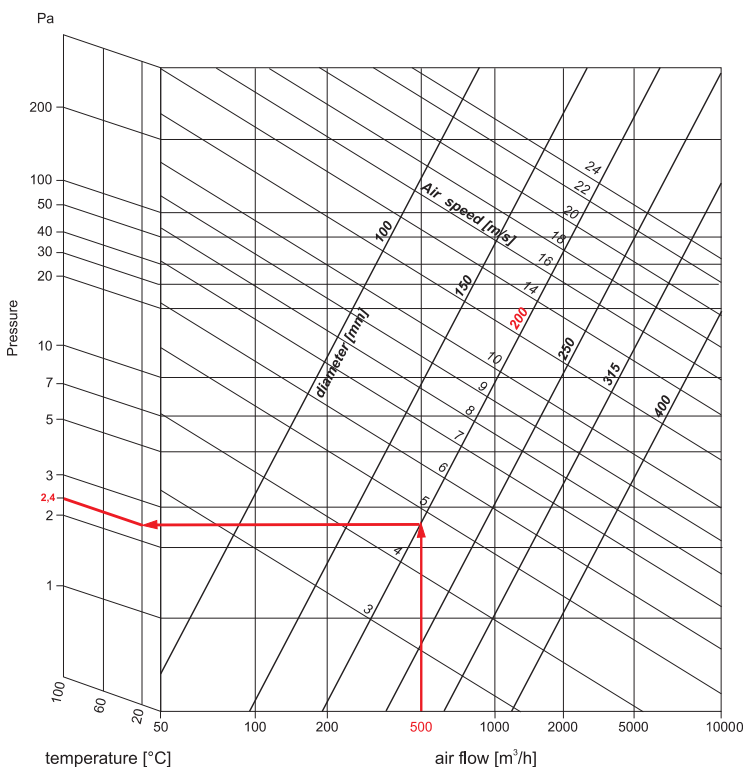

- Select a curve that matches the air duct diameter [mm], 200 mm in this case.
- Find the intersection point of this line with the vertical line of the required air flow in  $m^3/h$ , 500  $m^3/h$  in this case.
- The horizontal line that shows the pressure loss in Pa per 1 m straight air duct crosses this intersection point.
- Multiply pressure loss value (2.4 Pa/m at 20°C) by total air duct length to get the total pressure loss value. To calculate pressure loss in case of bends consider each bend as extra air duct meter.



# AIR DUCTS FOR VENTILATION, HEATING AND AIR CONDITIONING

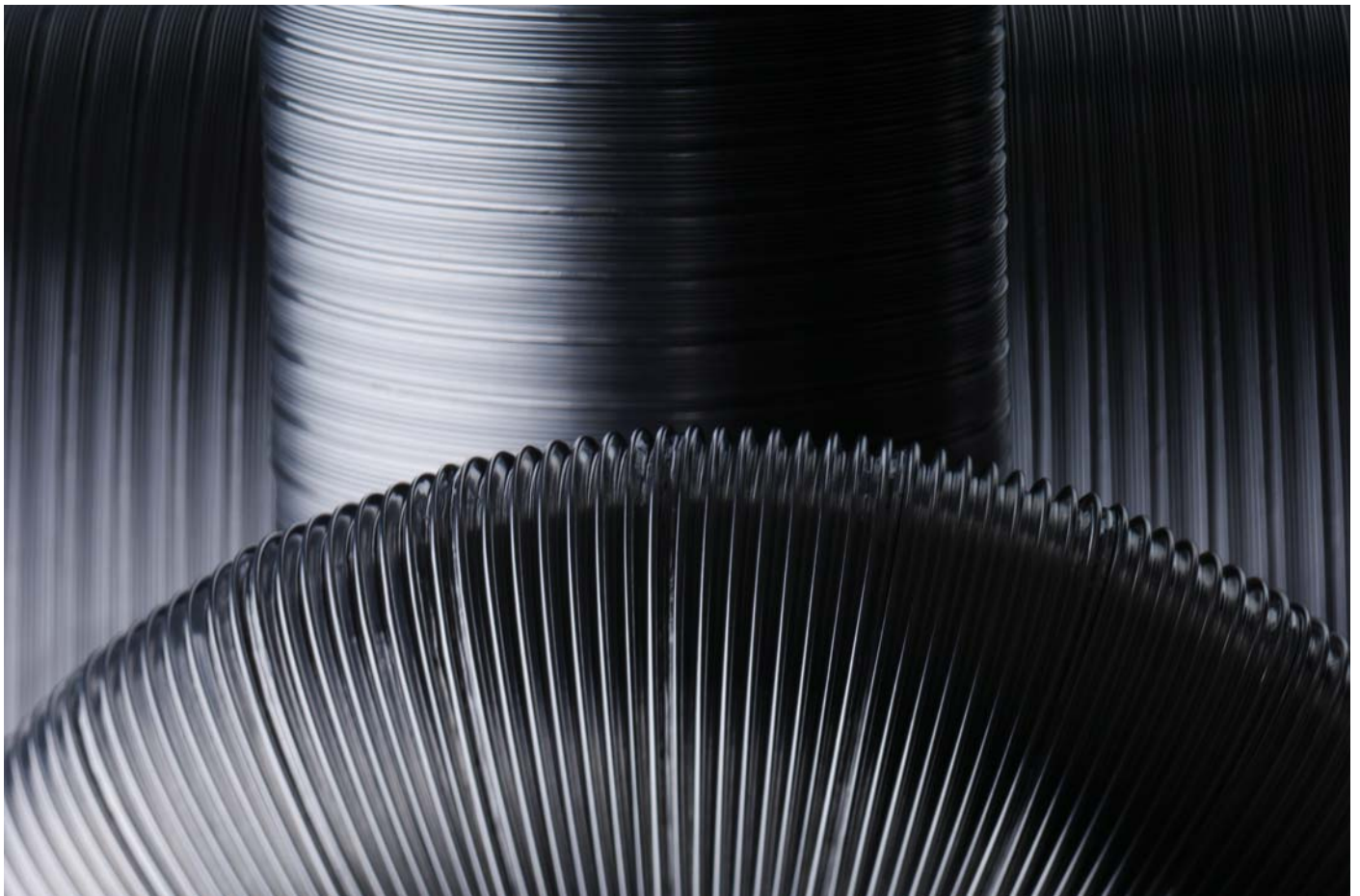



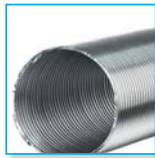

**Non-insulated air ducts  
Aluvent series**

Aluminium foil

page  
34

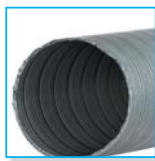

**Non-insulated air ducts  
Thermovent series**

galvanized and stainless steel

page  
35

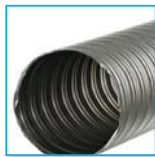

**Non-insulated air ducts  
Thermovent Aero series**

stainless steel

page  
36



**Non-insulated air ducts  
Thermovent Flex series**

stainless steel

page  
37

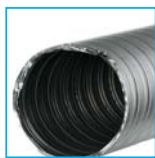

**Non-insulated air ducts  
Thermovent Aero Flex series**

stainless steel

page  
38

## Aluvent series



Semi-flexible aluminium air ducts

### Description

- Flexible spiral seam aluminium band air ducts with high aerodynamic and strength characteristics.

### Features

- Made of incombustible, corrosion-resisting aluminium band.
- Specially designed high-quality locks ensure high seam tightness and total air tightness of the ducts.

- Low dynamic losses.
- Low weight, high elasticity and easy mounting.

### Recommended application

- Applied in residential and industrial ventilation, air conditioning and heating systems with the maximum pressure 10 000 Pa.
- For supply and exhaust ventilation.

### Technical data

Item	Aluvent M	Aluvent N	Aluvent S	Aluvent D
Diameter range [mm]	80/100/110/120/125/130/140/150/160/180/200/250/315			
Material	Aluminium			
Number of layers	1	1	1	2
Total thickness [µm]	50	80	100	2x50
Operating temperature range [°C]	-30...+ 250			
Maximum air speed [m/s]	30			
Maximum operating pressure [Pa]	8 000	10 000	10 000	10 000
Minimum bend radius [mm]	0,7xD	0,73xD	0,76xD	0,85xD
Length [m]	1; 2; 2,5; 3; 6			

### Packing



Thermal packing



Polyethylene bag



Cardboard box

### Order code

Aluvent    type    Ø /    length

M  
N  
S  
D

### Accessories



## Thermovent series



Semi-flexible galvanized or stainless steel air ducts

### Description

- Semi-flexible stainless or galvanized steel spiral seam air ducts with high aerodynamic and strength characteristics.

### Features

- Made of incombustible, corrosion-resisting stainless steel or galvanized steel band.
- Increased thermal resistance (up to 700°C).
- Superdense high-quality triple locks ensure high seam tightness and total air tightness of the ducts.

- Low dynamic losses.
- Low weight and easy mounting.

### Recommended application

- Applied in residential and industrial ventilation, air conditioning and heating systems with the maximum pressure 10 000 Pa.
- For supply and exhaust ventilation.
- Applied in the systems of hot air removal from boiler houses and smoke exhaust systems.

### Technical data

Item	Thermovent N	Thermovent S	Thermovent N, Zn
Diameter range [mm]	80/100/110/120/125/130/140/150/160/180/200/250/315		
Material	Stainless steel	Stainless steel	Galvanized steel
Number of layers	1	1	1
Total thickness [µm]	80	100	80
Operating temperature range [°C]	-30...+700	-30...+700	-30...+700
Maximum air speed [m/s]	30	30	30
Maximum operating pressure [Pa]	10 000	10 000	10 000
Minimum bend radius [mm]	3xD	3xD	3xD
Length [m]	1; 2; 3; 6	1; 2; 3; 6	1; 2; 3; 6

### Packing



Cardboard box

### Order code

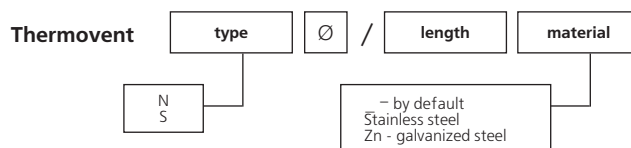

### Accessories



## Thermovent Aero series



Stainless steel air ducts with high temperature resistance

### Description

- Spiral seam stainless steel air ducts with high aerodynamic and strength characteristics.

### Features

- Made of incombustible corrosion-resisting stainless steel band.
- Increased thermal resistance (up to 800°C).
- Specially designed high-quality locks ensure high seam tightness and total air tightness of the ducts.

- Smooth internal surface ensures low dynamic losses.
- Low weight and easy mounting.

### Recommended application

- Applied in residential and industrial ventilation, air conditioning and heating systems with the maximum pressure 10 000 Pa.
- For supply and exhaust ventilation.
- Applied in the systems of hot air removal from boiler houses and smoke exhaust systems.

### Technical data

Item	Thermovent Aero
Diameter range [mm]	80/100/110/120/125/130/135/140/150/160 /180/200/250/300/350/400
Material	Stainless steel
Number of layers	1
Total thickness [µm]	100
Operating temperature range [°C]	-30...+800
Maximum air speed [m/s]	30
Maximum operating pressure [Pa]	10 000
Minimum bend radius [mm]	4xD (up to 200 mm diameter) and 4,5D (above 200 mm)
Length [m]	1; 2; 3; 6

### Packing



Cardboard box

### Order code

Thermovent Aero  /

### Accessories





## Thermovent Flex series



Semi-flexible stainless steel air ducts with high temperature resistance

### Description

- Spiral seam stainless steel air ducts with high aerodynamic and strength characteristics.

### Features

- Made of incombustible corrosion-resisting stainless steel band.
- Increased thermal resistance (up to 800°C).
- Specially designed high-quality locks ensure high seam tightness and total air tightness of the ducts.

- Smooth internal surface ensures low dynamic losses.
- Low weight and easy mounting.

### Recommended application

- Applied in residential and industrial ventilation, air conditioning and heating systems with the maximum pressure 10 000 Pa.
- For supply and exhaust ventilation.
- Applied in the systems of hot air removal from boiler houses and smoke exhaust systems.

### Technical data

Item	Thermovent Flex	
Diameter range [mm]	50/60/80/100/110/120/125/130/135/140/150/160/180/200/250/300/350/400	
Material	Stainless steel	
Number of layers	2	
Total thickness [µm]	100	
Operating temperature range [°C]	-30...+800	
Maximum air speed [m/s]	30	
Maximum operating pressure [Pa]	10 000	
Minimum bend radius [mm]	up to Ø 200 mm	4D
	above Ø 200 mm	4,5xD
Length [m]	1; 2; 3; 6	

### Packing



Cardboard box

### Order code

Thermovent Flex

Ø / length

### Accessories



## Thermovent Aero Flex series



Double-layer stainless steel air ducts with high temperature resistance

### Description

- Double-layer stainless steel spiral-seam air ducts with high aerodynamic and strength characteristics.

### Features

- Made of incombustible corrosion-resisting stainless steel band.
- Increased thermal resistance (up to 800°C).
- Specially designed high-quality locks ensure high seam tightness and total air tightness of the ducts.

- Smooth internal surface ensures low dynamic losses.
- Low weight and easy mounting.

### Recommended application

- Applied in residential and industrial ventilation, air conditioning and heating systems with the maximum pressure 10 000 Pa.
- For supply and exhaust ventilation.
- Applied in the systems of hot air removal from boiler houses and smoke exhaust systems.

### Technical data

Item		Thermovent Aero Flex
Diameter range [mm]		50/60/80/100/110/120/125/130/135/140 /150/160/180/200/250/300/350/400
Material		Stainless steel
Number of layers		2
Total thickness [µm]	Internal layer	100
	External layer	100
Operating temperature range [°C]		-30...+800
Maximum air speed [m/s]		30
Maximum operating pressure [Pa]		10 000
Minimum bend radius [mm]	up to Ø 200 mm	4D
	above Ø 200 mm	4,5xD
Length [m]		1; 2; 3; 6

### Packing



Cardboard box

### Order code

Thermovent Aero Flex  /

### Accessories



### Pressure loss diagram per 1 m stretched air duct

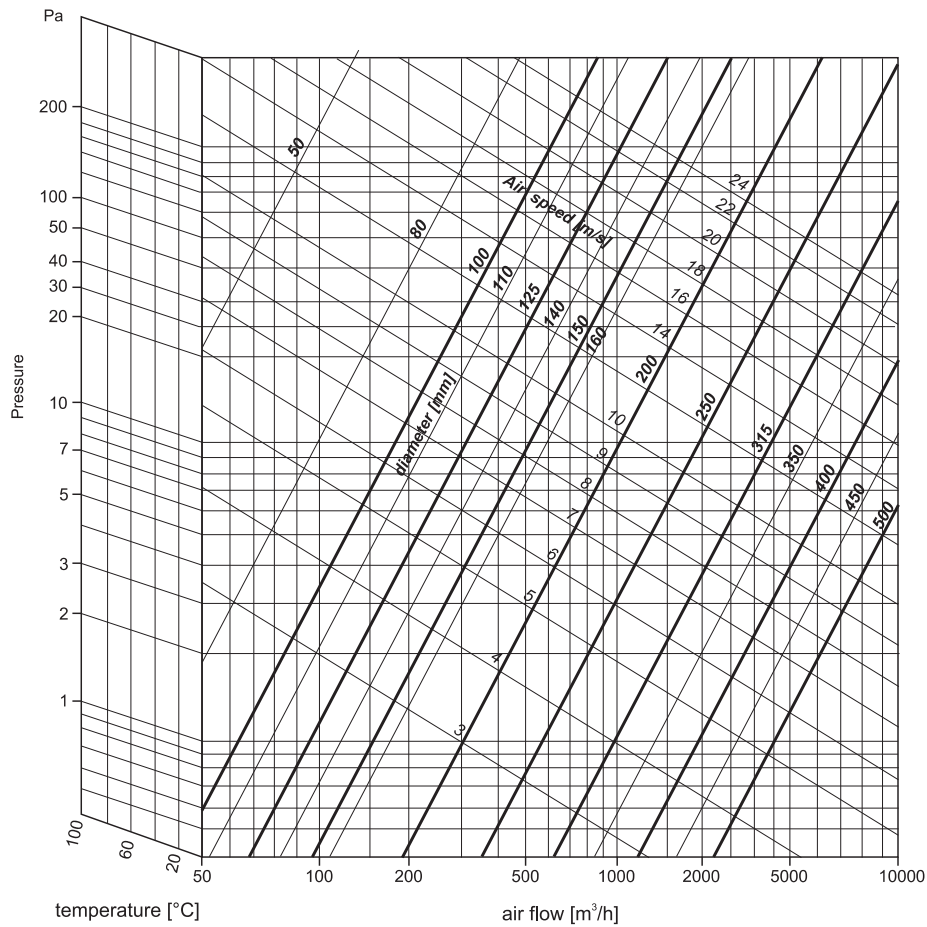

### Calculation example

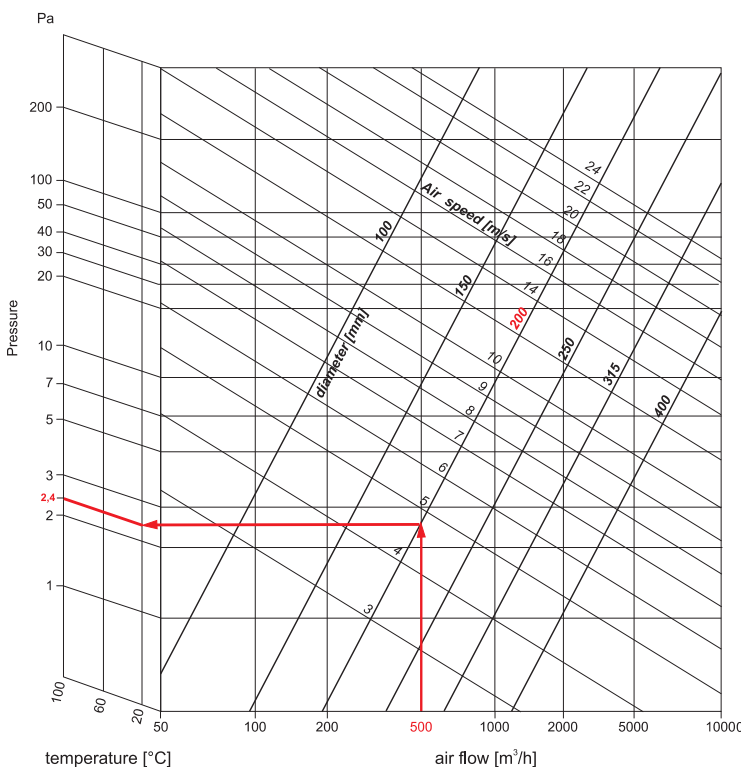

- Select a curve that matches the air duct diameter [mm], 200 mm in this case.
- Find the intersection point of this line with the vertical line of the required air flow in  $\text{m}^3/\text{h}$ , 500  $\text{m}^3/\text{h}$  in this case.
- The horizontal line that shows the pressure loss in Pa per 1 m straight air duct crosses this intersection point.
- Multiply pressure loss value (2.4 Pa/m at 20°C) by total air duct length to get the total pressure loss value. To calculate pressure loss in case of bends consider each bend as extra air duct meter.

**Table 2. Chemical resistance  
of flexible and semi-flexible Aluvent air ducts**

Air duct type	615, 6150	660, 661, 602, 607	606, 6061	600, 601	620, 6201, 621	Aluvent
DDT-kerosene	X	A	A	A	A	A
Skydrol-oil for hydraulic systems	X	O	O	O	O	O
Nitric acid 10%	A	A	A	A	A	A
Amyl alcohol	A	A	A	A	A	A
Ammonium hydrate	A	A	A	A	A	A
Acetylene	O	O	O	O	O	A
Acetone	A	X	X	X	O	A
Benzene	X	X	X	X	O	B
Potassium bicarbonate	A	A	A	A	A	A
Butyl alcohol	X	A	A	A	A	A
Butyl ether	O	A	A	A	A	O
Vinyl chloride (monomer)	X	X	X	X	O	O
Glycerine	A	C	C	C	C	A
Tannic acid	A	A	A	A	A	A
Potassium carbonate	A	A	A	A	A	X
Sodium carbonate	A	A	A	A	A	A
Xylene	X	X	O	O	O	A
Hydraulic oil	O	O	O	O	C	O
Methyl alcohol	A	A	A	A	A	A
Formic acid	B	O	O	O	C	B
Nitrobenzene	X	X	X	X	O	A
Ozone	X	A	A	A	A	B
Hydrogen peroxide	B	A	A	A	A	A
Perchloroethylene	X	O	O	O	O	B
Sodium chloride	A	A	A	A	A	B
Natural gas dry	A	A	A	A	A	B
Propane (gas)	A	A	A	A	A	A
Sulphuric acid 10%	A	A	A	A	A	B
Hydrogen sulfide, wet	A	O	O	O	O	A
Hydrogen sulfide, dry	A	O	O	O	O	A
Esters (non-flammable)	O	O	O	O	O	O
Hydrochloric acid 15%	A	A	A	A	A	O
Spirits	O	C	C	C	B	O
Toluene	X	X	X	X	O	A
Jet oil JP-1	X	A	A	A	A	O
Trichloroethylene (tri)	X	O	O	O	O	C



Heavy-flammable	N	N	J	J	J	J
Carbon monoxide	A	0	0	0	0	A
Carbon dioxide	A	A	A	A	A	A
Carbonic acid	A	A	A	A	A	A
Pheron 12	0	B	B	B	B	0
Ammonium phosphate	0	A	A	A	A	B
Sodium phosphate	A	A	A	A	A	A
Phosphoric acid 50%	A	A	A	A	A	B
Chlorine dry	X	0	0	0	0	B
Potassium chlorate	A	A	A	A	0	A
Aluminium chloride	A	A	A	A	A	B
Ammonium chloride	A	A	A	A	A	A
Ferric chloride	A	0	0	0	0	X
Antimonous chloride 50%	A	0	0	0	0	B
Zinc chloride	A	A	A	A	A	C
Ethylic alcohol	A	A	A	A	A	0

**A** - High resistance

**0** - No data

**B** - Medium resistance

**J** - Heavy flammable (Yes)

**C** - Relative resistance

**N** - Not flammable (No)

**X** - No resistance

**Table 3. Chemical resistance of semi-flexible Thermovent air ducts**

Air duct type	
Thermovent, Thermovent Aero, Thermovent Flex, Thermovent Aero Flex	
Ammonium hydroxide	Resistant
Nitric acid	Up to 30%, 100°C
Barium chloride, dehydrate	Up to 20%, 100°C
Isopropyl alcohol	Resistant
Hydrochloric acid	Up to 1%, 50°C
Potassium chromate	Resistant
Potassium bichromate	Resistant
Potassium hydroxide	Up to 50%, 20°C
Fuel oil	Resistant
Caustic soda	Up to 40%, 90°C
Sulphuric acid	Up to 3%, 50°C
Toluene	Resistant

# FITTINGS



**Cross Tee  
KM Series**

with polymeric coating

page  
44



**Cross Tee  
KM...Zn Series**

galvanized steel

page  
44



**T-joint  
TM Series**

with polymeric coating

page  
45



**T-joint  
TM...Zn Series**

galvanized steel

page  
45



**Y-shaped T-joint  
TMY Series**

with polymeric coating

page  
46



**Y-shaped T-joint  
TMY...Zn Series**

galvanized steel

page  
46



**Reducer  
RM Series**

with polymeric coating

page  
47



**Reducer  
RM...Zn Series**

galvanized steel











page  
47



**Flange  
FM Series**

with polymeric coating

page  
48

	<b>Flange FM...Zn Series</b>	page 48
	galvanized steel	
	<b>Reducer FMK Series</b>	page 49
	with polymeric coating	
	<b>Reducer FMK...Zn Series</b>	page 49
	galvanized steel	
	<b>Flange F Series</b>	page 50
	with polymeric coating	
	<b>Flange FK Series</b>	page 50
	galvanized steel	
	<b>Reducer PM series</b>	page 51
	with polymeric coating	
	<b>Reducer PM...Zn series</b>	page 51
	galvanized steel	
	<b>Clamps</b>	page 52
	<b>Bend holder (bracket) PDV series</b>	page 54
	<b>Mounting tapes</b>	page 55

## KM Series



## KM...Zn Series



### Overall dimensions

Model		Dimensions [mm]		
		D1	D2	B
KM 80	KM 80 Zn	80	80	170
KM 100	KM 100 Zn	100	100	190
KM 110	KM 110 Zn	110	110	200
KM 120	KM 120 Zn	120	120	210
KM 125	KM 125 Zn	125	125	215
KM 125/160	KM 125/160 Zn	125	160	215
KM 130	KM 130 Zn	130	130	220
KM 140	KM 140 Zn	140	140	230
KM 150	KM 150 Zn	150	150	240
KM 160	KM 160 Zn	160	160	250
KM 180	KM 180 Zn	180	180	260
KM 200	KM 200 Zn	200	200	300
KM 250	KM 250 Zn	250	250	350
KM 315	KM 315 Zn	315	315	415

### Application

- For branch connections of the air ducts used in residential, public and industrial ventilation systems.
- For connection of various air ducts and their integration into complex ventilation systems.

### Design

- Made of special steel with polymeric coating (KM series) or galvanized steel (KM...Zn series).
- The cross tee is designed for connection of 4 air ducts of the same diameter at 90° angle.
- The cross tee model **KM 125/160** is equipped with two  $\varnothing 125$  mm and two  $\varnothing 160$  mm flanges.
- Ventilation system components are fixed by clamps or any other fixing devices.

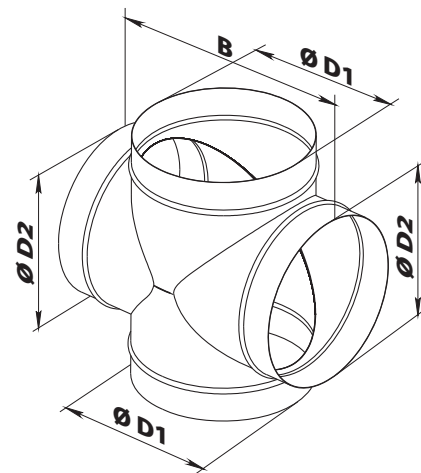

### Accessories





**TM  
Series**



**TM...Zn  
Series**



**Application**

- For branch connections of the air ducts used in residential, public and industrial ventilation systems.
- For connection of various air ducts and their integration into complex ventilation systems.

**Design**

- Made of special steel with polymeric coating (**TM** series) or galvanized steel (**TM...Zn** series).
- The T-joint is designed for connection of 3 air ducts at 90° angle.
- The **TM 125/160** T-joint model is equipped with two Ø 125 mm flanges and one Ø 160 mm flange.
- Ventilation system components are fixed by clamps or any other fixing devices.

**Overall dimensions**

Model		Dimensions [mm]		
		D1	D2	B
TM 80	TM 80 Zn	80	80	170
TM 100	TM 100 Zn	100	100	190
TM 110	TM 110 Zn	110	110	200
TM 120	TM 120 Zn	120	120	210
TM 125	TM 125 Zn	125	125	215
TM 125/160	TM 125/160 Zn	125	160	215
TM 130	TM 130 Zn	130	130	220
TM 140	TM 140 Zn	140	140	230
TM 150	TM 150 Zn	150	150	240
TM 160	TM 160 Zn	160	160	250
TM 180	TM 180 Zn	180	180	260
TM 200	TM 200 Zn	200	200	300
TM 250	TM 250 Zn	250	250	350
TM 315	TM 315 Zn	315	315	415

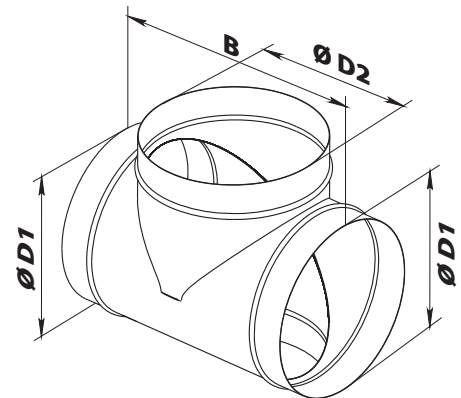

**Accessories**



# FITTINGS

## Y-SHAPED T-JOINT

### TMY Series



### TMY...Zn Series



#### Overall dimensions

Model		Dimensions [mm]	
		D	B
TMY 80	TMY 80 Zn	80	170
TMY 100	TMY 100 Zn	100	190
TMY 110	TMY 110 Zn	110	200
TMY 120	TMY 120 Zn	120	210
TMY 125	TMY 125 Zn	125	215
TMY 130	TMY 130 Zn	130	220
TMY 140	TMY 140 Zn	140	230
TMY 150	TMY 150 Zn	150	240
TMY 160	TMY 160 Zn	160	250
TMY 180	TMY 180 Zn	180	260
TMY 200	TMY 200 Zn	200	300
TMY 250	TMY 250 Zn	250	350
TMY 315	TMY 315 Zn	315	415

#### Application

- For branch connections of the air ducts used in residential, public and industrial ventilation systems.
- For connection of various air ducts and their integration into complex ventilation systems.

#### Design

- Made of special steel with polymeric coating (**TMY** series) or galvanized steel (**TMY...Zn** series).
- The T-joint is designed for connection of 3 air ducts with the same diameter at 120° angle.
- Ventilation system components are fixed by clamps or any other fixing devices.

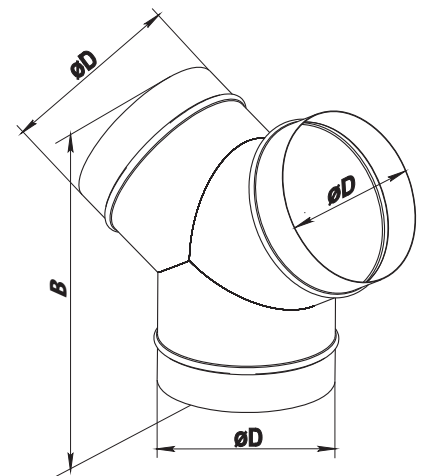

#### Accessories



**RM  
Series**



**RM...Zn  
Series**



**Overall dimensions**

Model		Dimensions [mm]		
		D	D1	L
RM 80/100	RM 80/100 Zn	80	100	115
RM 100/125	RM 100/125 Zn	100	125	125
RM 100/120	RM 100/120 Zn	100	120	125
RM 125/150	RM 125/150 Zn	125	150	125
RM 125/160	RM 125/160 Zn	125	160	144
RM 150/160	RM 150/160 Zn	150	160	172
RM 150/200	RM 150/200 Zn	150	200	172
RM 160/200	RM 160/200 Zn	160	200	154
RM 200/250	RM 200/250 Zn	200	250	172
RM 250/315	RM 250/315 Zn	250	315	195

**Application**

- For branch connections of the air ducts used in residential, public and industrial ventilation systems.
- For connection of various air ducts and their integration into complex ventilation systems.
- For connection of two various air duct diameters.

**Design**

- Made of special steel with polymeric coating (RM series) or galvanized steel (RM...Zn series).
- The reducer is designed for connection of two air ducts with various diameters.
- Ventilation system components are fixed by clamps or any other fixing devices.

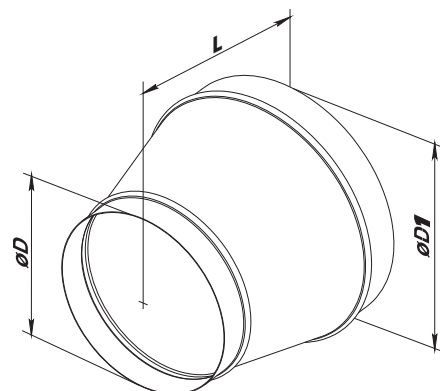

**Accessories**



## FM Series



## FM...Zn Series



### Application

- For connection of flexible and plastic air ducts of the respective diameter.
- For wall or ceiling mounting.

### Design

- Made of special steel with polymeric coating (**FM** series) or galvanized steel (**FM...Zn** series).
- Fixing to wall or ceiling with screws.

### Overall dimensions

Model		Dimensions [mm]		
		D	D1	L
FM 80	FM 80 Zn	80	116	62
FM 100	FM 100 Zn	100	136	62
FM 110	FM 110 Zn	110	146	62
FM 120	FM 120 Zn	120	156	62
FM 125	FM 125 Zn	125	162	62
FM 130	FM 130 Zn	130	166	62
FM 140	FM 140 Zn	140	176	62
FM 150	FM 150 Zn	150	186	62
FM 160	FM 160 Zn	160	196	62
FM 180	FM 180 Zn	180	206	62
FM 200	FM 200 Zn	200	236	62
FM 250	FM 250 Zn	250 <td 286	62	
FM 315	FM 315 Zn	315	351	62

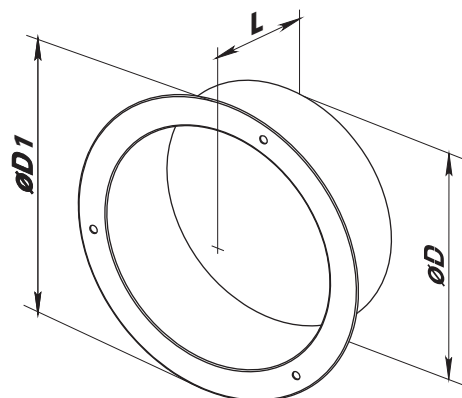

### Accessories





**FMK  
Series**



**FMK...Zn  
Series**



**Application**

- For connection of flexible and plastic air ducts of the respective diameter.
- For wall or ceiling mounting.

**Design**

- Made of special steel with polymeric coating (**FMK** series) or galvanized steel (**FMK...Zn** series).
- The flanges are equipped with a rectangular connecting plate.
- Fixing to wall or ceiling with screws.

**Overall dimensions**

Model		Dimensions [mm]			
		H	B	D	L
FMK 80	FMK 80 Zn	130	114	80	50
FMK 100	FMK 100 Zn	150	134	100	50
FMK 110	FMK 110 Zn	158	142	110	50
FMK 120	FMK 120 Zn	162	146	120	50
FMK 125	FMK 125 Zn	170	156	125	50
FMK 130	FMK 130 Zn	180	164	130	50
FMK 140	FMK 140 Zn	190	174	140	50
FMK 150	FMK 150 Zn	204	188	150	50
FMK 160	FMK 160 Zn	210	194	160	50
FMK 180	FMK 180 Zn	220	204	180	50
FMK 200	FMK 200 Zn	250	234	220	50
FMK 250	FMK 250 Zn	300	284	250	50
FMK 315	FMK 315 Zn	360	344	315	50

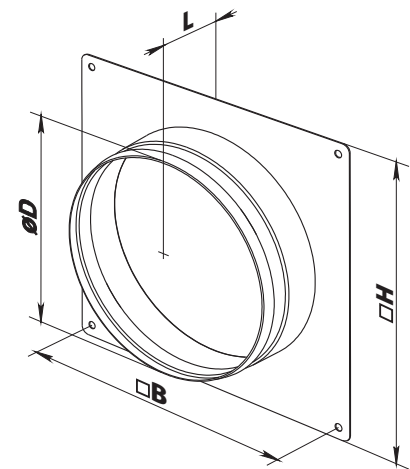

**Accessories**



## F Series



## FK Series



### Application

- For connection of flexible air ducts, plastic ducts and air disk valves of suitable diameter without flanges.
- For wall or ceiling mounting.

### Design

- Made of high-quality plastic.
- F Series flanges are equipped with a retaining ring for fixation of flexible air ducts.
- The flange model **F 200/150** can be used as a connector for the air disk valves A 200 VR and A 200 R.
- FK Series flanges are equipped with a connecting plate.
- Fixing to wall or ceiling with screws.

### Overall dimensions

Model	Dimensions [mm]			
	D	D1	D2	L
F 80	80	115	120	62
F 100	100	132	139	62
F 125	125	157	165	62
F 150	150	179	188	62
F 200	200	232	240	62
F 200/150	150	200	179	85
F 250	250	283	290	62
F 315	315	360	356	62

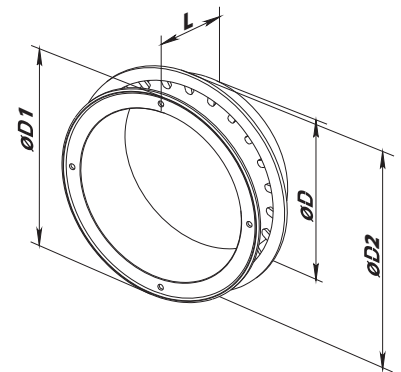

Model	Dimensions [mm]			
	H	B	D	L
FK 100	185	169	100	34
FK 120	185	169	120	34
FK 125	185	169	125	34

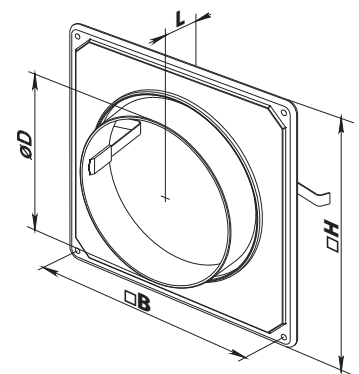

### Accessories



**PM  
Series**



**PM...Zn  
Series**



**Application**

- For connection of flexible air ducts of the respective diameter.

**Design**

- Made of special steel with polymeric coating (**PM** series) or galvanized steel (**PM...Zn** series).
- Fixing with clamps.

**Overall dimensions**

Model		Dimensions [mm]	
		D	L
PM 80	PM 80 Zn	80	62
PM 100	PM 100 Zn	100	62
PM 110	PM 110 Zn	110	62
PM 120	PM 120 Zn	120	62
PM 125	PM 125 Zn	125	62
PM 130	PM 130 Zn	130	62
PM 140	PM 140 Zn	140	62
PM 150	PM 150 Zn	150	62
PM 160	PM 160 Zn	160	62
PM 180	PM 180 Zn	180	62
PM 200	PM 200 Zn	200	62
PM 250	PM 250 Zn	250	62
PM 315	PM 315 Zn	315	62

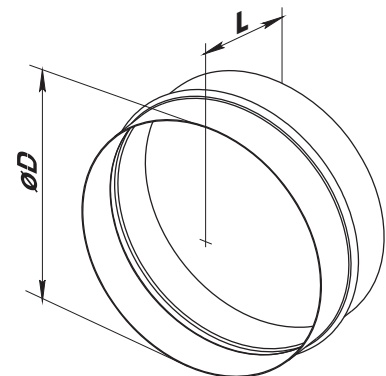

**Accessories**



## CZK Series



### Application

The quick-release clamps are designed for quick and reliable connection of various round ventilation system components.

### Design

The clamp is made of galvanized steel band and sealed with foamed rubber on the internal side for vibration reducing. The clamp is suitable for wall or ceiling mounting.

### Overall dimensions

Model	Dimensions [mm]		Weight [kg]
	ØD	L	
CZK 100	100	204	0,21
CZK 125	125	229	0,22
CZK 150	150	254	0,25
CZK 160	160	264	0,26
CZK 200	200	304	0,31
CZK 250	250	354	0,35
CZK 315	315	419	0,42

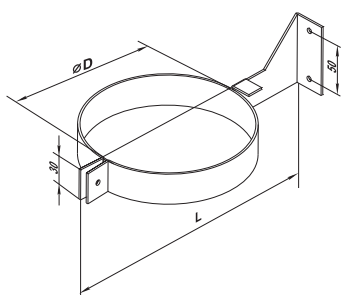

## CZ Series



### Application

The quick-release clamp is designed for quick and reliable mounting and connection of various round ventilation system components. The clamps facilitate installation process and fan removal for servicing and maintenance.

### Design

The clamp is made of galvanized steel band and sealed with foamed rubber on the internal side for better tight connection and vibration reducing. The quick-release clamps are tightened with two bolts.

### Overall dimensions

Model	Dimensions [mm]		Weight [kg]
	ØD	H	
CZ 100	100	172	0,206
CZ 125	125	198	0,232
CZ 150	150	224	0,296
CZ 160	160	232	0,358
CZ 200	200	274	0,42
CZ 250	250	326	0,55
CZ 315	315	380	0,65

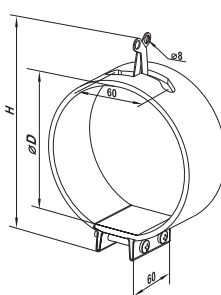

## C series (nylon)



### Application

The nylon clamp is one of the fastest, cost-effective and comfortable fixing devices for connection of the air ducts to the branch pipe and interconnection any ductworks. Suitable for operation range from -40°C up to +85°C.

### Design

The clamps are made of high quality self-extinguishing nylon with high mechanical durability. The edged locking device provides any diameter fixation. The clamps length varies from 370 mm to 1220 mm and the width from 4.8 to 9 mm. NZC snips can be supplied together with clamps for more comfortable tightening and cutting.

### Overall dimensions

Model	Dimensions [mm]		
	ØD	H	L
C 370/100 N	102	4,8	370
C 530/100 N	140	7,6	530
C 710/100 N	190	9	710
C 780/100 N	229	9	780
C 912/100 N	263	9	912
C1220/100 N	365	9	1220



NZC snips



### C Series



### CB Series



### CBR Series



#### Application

The clamps are designed for quick and reliable mounting and connection of various round ventilation system components. The clamps facilitate installation process and fan removal for servicing and maintenance.

#### Design

C series clamps are made of stainless steel band and CZ series clamps are made of galvanized steel band. The clamps are tightened with a screw.

CB series clamps are the stainless steel quick-release clamps equipped with a stainless steel swing screw. The clamps are tightened with a screw.

The CBR 3000 model is a band clamp in plastic casing (roll 30 m x 9 mm x 0.8 mm + 50 locking devices SU 50). Get the required clamp diameter with a clamp band of respective length and a locking device. The clamps are tightened with a screw.

Snip cutters are everything you need to get the required clamp diameter as the plastic casing

has a special design and necessary marking.

Use:

1. Bend the edge of the band;
2. Fix the bent end inside the band holder;
3. Turn the band holder up to the required diameter marking on the casing;
4. Cut the band according to the marking on the casing;
5. Fix the locking device on the band clamp.

#### Overall dimensions

Model	Dimensions [mm]	
	ØD	H
C 100	90-110	9
C 125	110-130	9
C 150	140-160	9
C 160	150-170	9
C 200	190-210	9
C 250	240-260	9
C 315	300-330	9

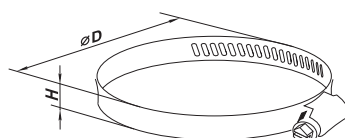
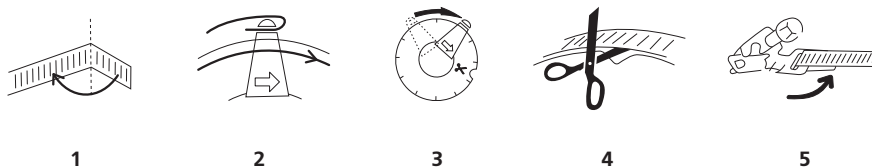

Locking device SU 50 for CBR 3000

#### Overall dimensions

Model	Dimensions [mm]	
	ØD	H
CB 60-110	60-110	9
CB 60-135	60-135	9
CB 60-165	60-165	9



Easy locking mechanism for the CB and CBR clamps

## PDV Series



### Application

Quick and reliable mounting of round air ducts at 90° angle. Provides correct bend angle of flexible air ducts to reduce air resistance and noise in the system.

Reduces energy demand of ventilation system and increases its efficiency due to even structure and no sagging that disturb the smooth air motion in the

duct. The multi-functional design allows using the wall holders for 80 to 400 mm flexible ducts.

### Design

Wall holder is made of high-quality plastic that provides correct bending and is not deformed due to air duct deflection. The air duct is fixed to the holder with nylon clamps.

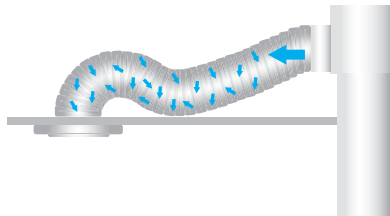

### Wrong mounting

air deflection increases air resistance and energy demand of the system.

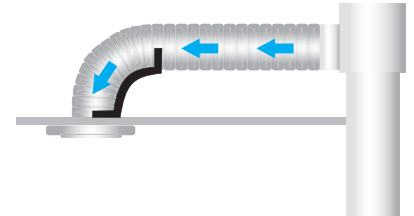

### Correct mounting

correct use of the wall holder reduces air resistance and energy demand of the system.

### Mounting example of flexible air ducts with the wall holder

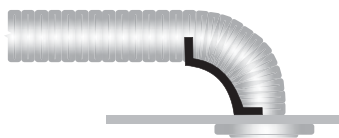

End-to-end mounting

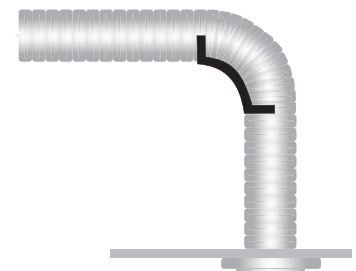

Suspended mounting

## ALT Series



## ART Series

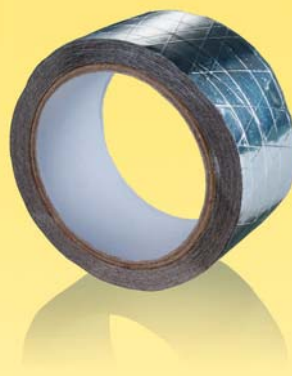

## PVT Series



### Application

Insulating material for various construction, repair and mounting operations at ventilation and air conditioning systems.

Insulation and protection of pipeline butt joints, air ducts, casings, assembly units, etc.

Sealing of joints and seams in case of reflecting material insulation to reduce thermal losses.

Reliable protection of equipment components against vapour, dirt and dust penetration. Corrosion protection.

### Design

**The aluminium adhesive tape ALT** is a composite material that consists of aluminium and PET foil covered with glue layer. The tape is supplied in rolls and the glue layer is protected with an extra protecting layer.

**The aluminium adhesive tape ART** is a composite material that consists of aluminium foil reinforced with PET film and fibreglass that is covered with glue. Due to synthetic fibres the tape has higher mechanical durability as com-

pared to standard adhesive tape.

**The adhesive PVC tape** is an insulation tape made of plasticized PVC base covered with a glue layer.

- initial good adhesion only increases with time;
- sufficient stability against sliding;
- high thermal resistance;
- high solvent resistance;
- increased UV resistance;
- durability.

### ALT and ART tape overall dimensions

	ALT 050/50	ALT 050/10	ART 050/50	ART 050/10
Length [m]	50	10	50	10
Width [mm]	50	50	50	50
Base thickness [µm]	30	30	55	55
Total tape thickness [µm]	32	32	96	96
Breaking force	57 N / 25 mm <sup>2</sup>	57 N / 25 mm <sup>2</sup>	336 N / 25 mm <sup>2</sup>	336 N / 25 mm <sup>2</sup>
Elongation at break [no more %]	3	3	6	6
Adhesiveness	8,25 N / 25 mm <sup>2</sup>	8,25 N / 25 mm <sup>2</sup>	10 N / 25 mm <sup>2</sup>	10 N / 25 mm <sup>2</sup>
Operating temperature [°C]	+10 ... +40	+10 ... +40	+10 ... +40	+10 ... +40
Max. working area surface [°C]	+100	+100	+100	+100
UV-resistance	yes	yes	yes	yes

### PVT tape overall dimensions

Type	Length [m]	Width [mm]	Thickness [mm]
PVT 050/10	10	50	0,18
PVT 050/30	30	50	0,18
PVT 050/50	50	50	0,18





**VENTILATION SYSTEM**  
[www.ventilation-system.com](http://www.ventilation-system.com)

flexible ducts  
and fittings



**VENTS reserves the rights to modify any of its products' features, designs, components and specifications at any time and without notice to maintain the development and quality of manufactured goods.**