



VENTS VN

SINGLE PIPE EXHAUST VENTILATION



CONTENTS

Ventilation in your house	2
Design and modifications of VN fans	4
Ventilation unit VNV-1 80	6
VN fans specifications	7
Fire-proof case for in-build installation KP 80	8
Plastic case for in-build installation KV 80	9
Fan in the fire-proof case VNV-1 80 KP	10
Fan in the plastic case VNV-1 80 KV	11
Fans VN-1 80 and VN 80	12
Additional advantages of the fan	13
Accessories	14
Fire-preventing valve PL 16	15
Calculation of air shafts in multi-floor buildings	16
Connecting diagrams	18
Sample of ventilation system	20
Certificates	21

Fast development and boost of the building sector, application of new and perspective technologies of house-building have set special requirements not only to the design of buildings, but also to the internal systems of buildings such as water-supply, sewage system and, of course, ventilation.

Availability of mechanical and energy-saving ventilation is an obligatory condition for modern multistory building. Most applied system of ventilation is one-pipe system, when exhaust of air from several apartments is made through a single ventilation shaft. The shaft can serve several apartments.

Just for such cases a flexible ventilation system becomes ideal that is designed at the stage of construction and meets a number of important requirements such as fire safety, minimum mounting space, modern design, simple control of functions and modes of fan operation to provide maximum comfort in the apartment. VENTS VN fans combining maximum efficiency of operation with absolute fire-proofness can fully satisfy these requirements.

Ventilation arrangement in residential houses with one-pipe system is fulfilled as follows.

Fresh air intake

Fresh air from the outside comes through air supply devices (a window or wall ventilator) into bedrooms and living quarters without dust or street noise. Vents can be mounted in walls or windows, have manual or automatic control, sound insulation and air consumption control function.

Exhaust of the used air

Air from the living quarters is removed through non-living rooms (kitchen, toilet, bathroom) into the common exhaust ventilation system by VN fans that provide effective ventilation at relatively low cost.

Fire prevention

To prevent penetration of fire and smoke into other rooms and to other floors through the air ducts of the ventilation system during a fire the following solutions are applied:

1. Fireproof case. High fire-resisting characteristics of the case allow to use the fans to meet the increased fire-prevention requirements while building multistory residential buildings.
2. Fire-retarding valve is installed in the ducts of ventilation channels that are coming through fire-proof walls and ceilings.

See more detailed description in the relevant sections on pages 8 and 15

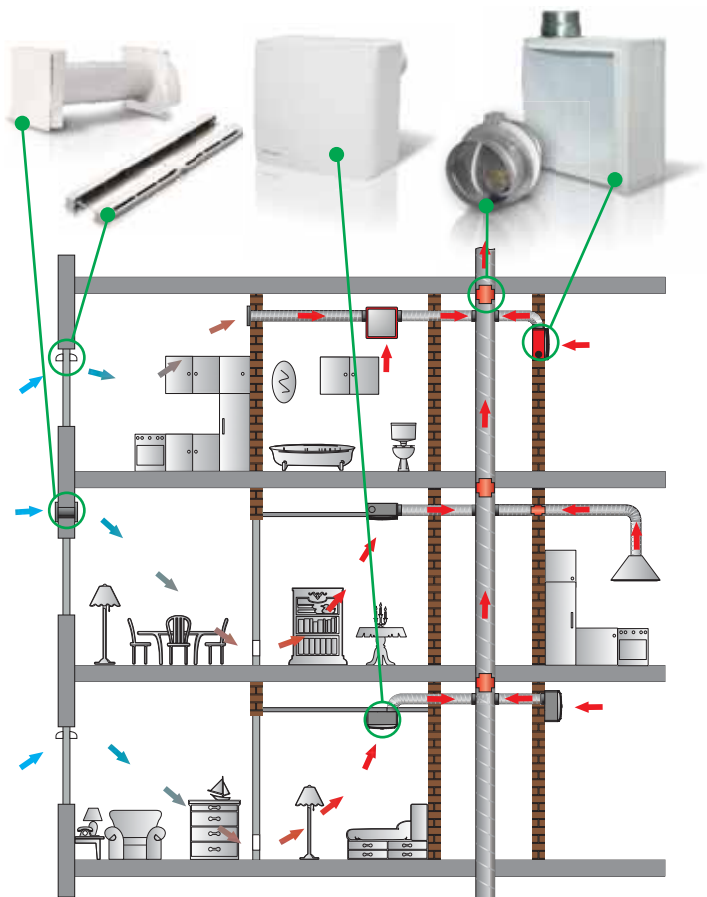

Various international norms	Types of rooms		
	Kitchens	Bathrooms	Toilets
	m ³ /h	m ³ /h	m ³ /h
DBN V.2.2-15-2005	90	25-50	50
DIN 18017/3	60-100	40 - 60	20 - 30
DIN 1946/6	40 - 60	40 - 60	20 - 30
ECE Compendium	36 - 180	36 - 180	-
BSF 199838	36 - 54	36 - 108	36
ČR	100 - 150	60	25

Sanitary norms demand ventilation of bathrooms and toilets in the flats, hotels and other buildings (see table). One-pipe ventilation system based on VENTS VN fans has convincing advantages in this sphere.



VENTS fans of VN series uniquely combines a number of features:

- the fan maintains stable high pressure changing automatically the speed of turbine rotation depending on the resistance level in the system;
- available special accessories turn VENTS VN fans into a completely fire-proof unit recommended for the use in multistory buildings;
- speed switch systems of the fan allow to program the optimal mode of the fan operation at the stage of its installation;
- the fan can be used for continuous non-stop work and, if necessary, it can switch automatically to the mode of increased output;
- low noise level of the fan (~ only 26 dBA at the lowest speed) allows to call it the quietest in its class.

VN series fans maintain high pressure in the systems of ducts by increasing the rotation speed depending on the change of resistance in the system and, thus, keeping the air flow rate at the same level at:

- simultaneous work of a big number of fans of the ventilation system;
- maximum load on the assembled air line;
- insufficient air intake;
- high resistance of the roof hood.



Ideally balanced turbine, thoroughly elaborated design of the case and automatic selection of the operation mode ensure noiseless work of VN series fans.

MODIFICATION FOR IN-BUILD MOUNTING

Fan with fire-proof case
VNV-1 80 KP

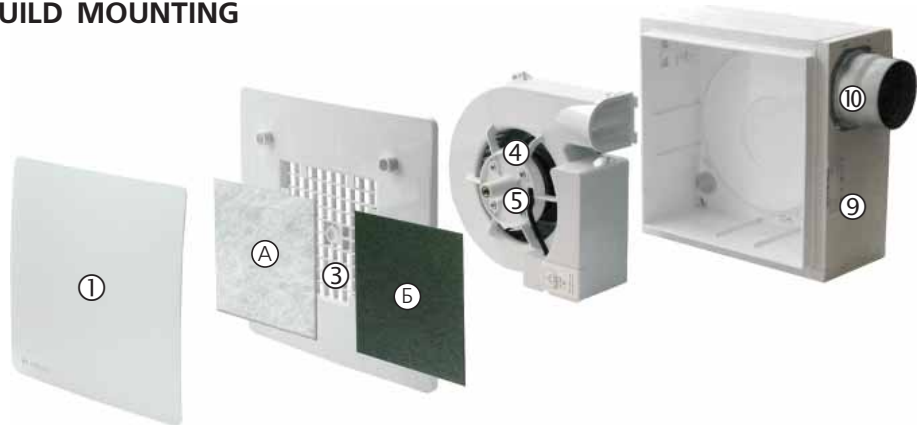

Fan with plastic case
VNV-1 80 KV

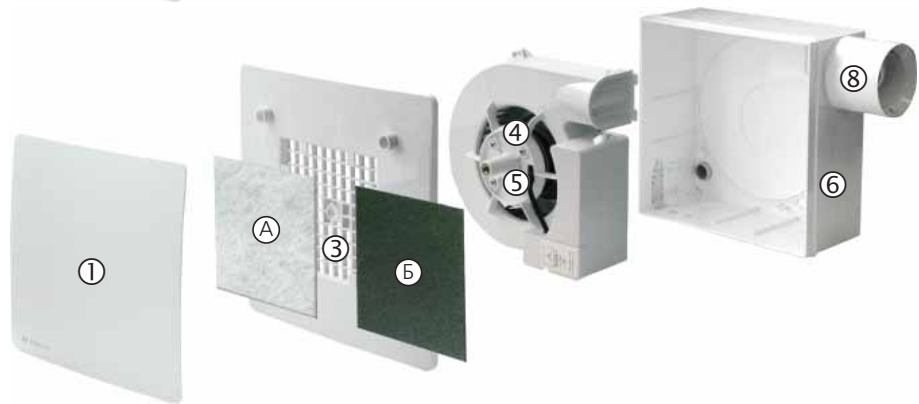

MODIFICATION FOR THE WALL MOUNTING

Fan VN-1 80



Fan VN 80

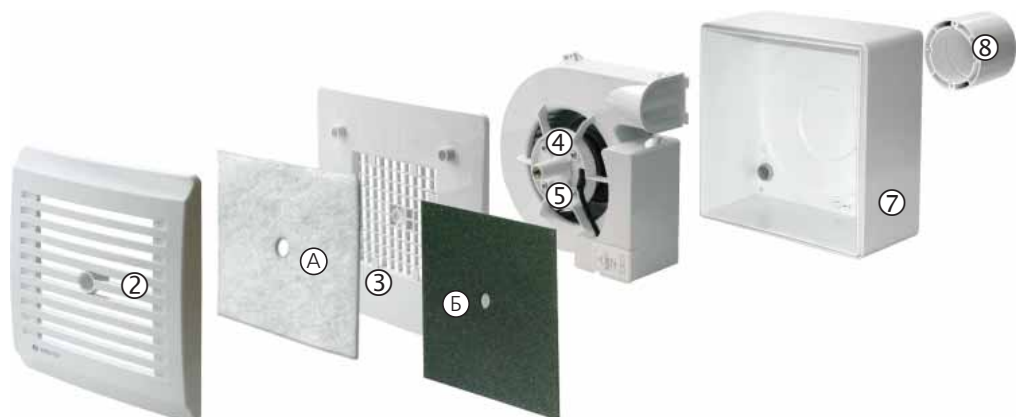

- ① **Front panel**
Front panel of the fan. Due to modern and simple panel design the fan harmoniously adds to any room interior.
- ② **Grille**
Decorative grille represents the front panel of the fan. Due to modern and simple panel design the fan harmoniously adds to any room interior.
- ③ **Filter**
To protect the motor and impeller as well as the assembled air line from penetration of contaminants present in the air a filter element made from polyether is used. Purification class G4.
- ④ **Helix case**
Made of durable ABS plastic. It is designed so that the best aerodynamic characteristics of the fan are achieved. The fan is easily mounted into the case with the help of clips without any efforts.
- ⑤ **Motor**
To ensure the safe and lasting operation, the two- or three-speed motors on rolling bearings are used, that are designed in cooperation with the company **ebmpapst** that is the leading motor manufacturer. Depending on resistance in ventilation system, the necessary output level in ventilator can be set independently. The automatic selection of the optimal mode of operation makes it possible to save the electric power considerably. The impeller wheel has the forward-curved blades. To achieve the precise characteristics, low noise level and safe operation, each turbine is subject to dynamic balancing when assembling.
- ⑥ **Plastic case for through-the-wall mounting**
Mounted in a wall during the finishing works. The case is made of high-quality and durable ABS plastic. Equipped with a roll over check valve and makes possible connection of additional connecting pipes for ventilation of a second room.
- ⑦ **Plastic case for wall mounting**
Made of high-quality and durable ABS plastic, equipped with a roll over check valve.
- ⑧ **Pressure isolated check valve**
A roll over check valve is foreseen in the plastic case that prevents penetration of air from the shaft into the room when the fan is switched off. When the fan is switched on the air is exhausted directly into the shaft.
- ⑨ **Fire proof case for through-the-wall mounting**
Serves to protect the room from penetration of combustion products through the air ducts during a fire. Made from silicate plates manufactured according to a special cement technique on the calcium silicate basis. Plates do not contain asbestos and possess high mechanical and insulation properties, and are hygroscopic and vapor permeable, that is why humidity is regulated by physical parameters of the material. High fire-resisting characteristics of the case make possible to use the fan to meet increased fire-prevention requirements for construction of the multistory buildings. Fireproof case is certified in the territory of Ukraine and CIS countries.
- ⑩ **Fire retarding valve**
Serves to prevent penetration of fire and flame through the ducts. At the temperature rise in the shaft up to 90°C a fuse is activated and the valve automatically shuts off the access of hot air preventing penetration of fire and smoke through the ventilation shaft system. Valve membrane is made of stainless steel. When the fan is switched on it serves as a check valve preventing transfer of air from the ventilation shaft.

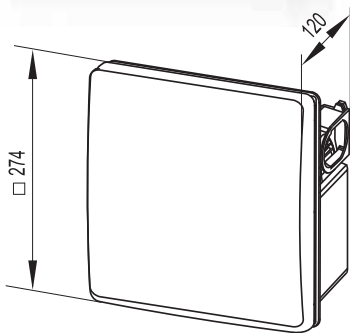

Description:

- installed in a plastic or fireproof case;
- for periodical or continuous work;
- the front panel is made of high quality and durable ABS plastic;
- automatically maintains pressure and air flow rate in the duct;
- economy effective 2- or 3-speed motor with minimum energy consumption;
- ball bearings increase the service life of the motor;
- to achieve precise characteristics, low noise level and safe work of the fan each turbine undergoes dynamic balancing;

Application:

- in the ventilation systems of multistory residential and public buildings;
- in buildings with one-pipe ventilation system;
- mounting in kitchens, bathrooms, toilets, storerooms and other household rooms.



- equipped with a filter from polyether for protection of the motor and impeller from penetration of contaminants (purification class G4);
- turnable front cover conceals the drawbacks of installation of the fan case;
- installed into the case with the help of clips without the use of any additional tools;

Options of 2-speed fans:

- T – with a timer
- TR – with an adjustable timer
- I – with an interval switch
- F – with a photo sensor
- N – with a humidity sensor



Fastening of the screen during mounting of the fan foresees adjustment of the turning angle of the front panel relative to the case that may conceal the drawbacks of mounting. The front panel can be turned by 10°.

Specifications:

Model	VNV-1 80	VNV-1A 80	VNV-1B 80	VNV-1C 80	VNV-1D 80
Number of speeds	3	2	2	3	2
Voltage, V (50 Hz)	220-240	220-240	220-240	220-240	220-240
Power consumption, W	17/27/48	12/17	12/27	12/17/27	17/27
Input current, A	0,14/0,18/0,21	0,12/0,14	0,12/0,18	0,12/0,14/0,18	0,14/0,18
Connection to power network, mm ²	4x1,5	3x1,5	3x1,5	4x1,5	3x1,5
Max. air consumption, m ³ /h	63/102/150	35/63	35/102	35/63/102	63/102
RPM	1350/1830/2640	890/1350	890/1830	890/1350/1830	1350/1830
Sound pressure level at distance of 3m, dBA	30/35,2/43,7	26,6/30	26,6/35,2	26,6/30/35,2	30/35,2
Max. temperature of the transported air, °C	50	50	50	50	50

Order code:

VNV-1	air capacity m ³ /h	80	options*
	A - 60/100/150;		T
	B - 35/60;		TR
	C - 35/100;		i
	D - 35/60/100;		F
			N

* Only for 2-speed fans

Accessories:



See description and list of accessories on p. 8, 9, 14

Aerodynamic characteristics:

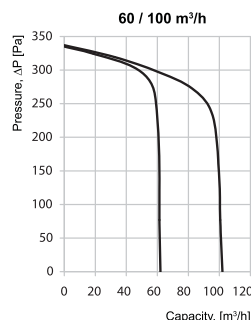
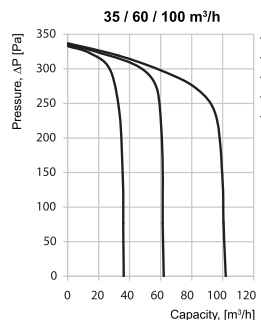
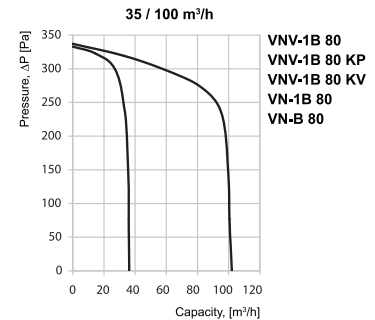
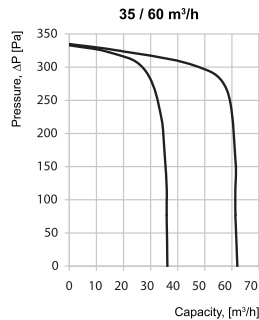
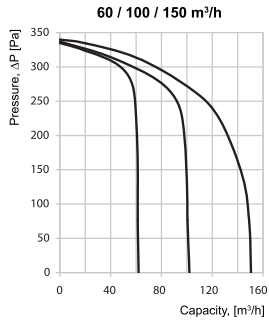

This steep characteristic reflects the high potential of VNV fans concerning pressure while keeping the constant air consumption, which allows simultaneous work of a number of fans in one ventilation shaft:

- available pressure till 270 Pa at 35 m³/h
- available pressure till 260 Pa at 60 m³/h
- available pressure till 220 Pa at 100 m³/h

Base models:

2- or 3-speed fans. Speed is changed with an external manual switch (e.g. P3-1-300 – is not a part of delivery set).

Description of options (only for 2-speed fans):



T – with a timer:

The fan is switched on to the maximum speed manually with an external switch, turn-on delay time is 50sec. It is returned to the default setting by the timer, run-down time is 6 min. Operation with the constantly turned-on low speed or without it is possible.



TR – with an adjustable timer:

The fan is switched on to the maximum speed manually with an external switch. Turn-on delay time is set with the internal regulator from 0 to 150 seconds. Run-down time is set with the internal regulator from 2 to 30 minutes. Operation with the constantly turned-on low speed or without it is possible



I – with an interval switch:

The fan runs with periodical activation of the maximum speed. Interval between activation is set with the internal regulator from 0.5 to 15 hours. Run-down time is 10 minutes. The fan can be switched on manually with the external switch, turn-on delay time is 50 seconds. Operation with the constantly turned-on low speed or without it is possible.



F – with a photo sensor:

The fan switches on to the maximum speed after the light is turned on in the room with turn-on delay of 50 seconds. When the luminance drops below the threshold value, the run-down time is secured by the timer and is set with the internal regulator from 2 to 30 minutes. Operation with constantly turned-on low speed is possible.



N – with a humidity sensor:

The fan switches on to the maximum speed upon increase of the relative humidity level in the room. It is switched off when the set humidity level drops by 10%. Humidity threshold is adjusted from 60% to 90%. The fan can be switched on to the maximum speed forcibly, turn-on delay time is 50 seconds, and the run-down time is set with the internal regulator from 2 to 30 minutes. Operation of the fan with the constantly turned-on low speed is possible.

See connecting diagrams on pages 18-19.

FIREPROOF CASE FOR THROUGH-THE-WALL MOUNTING KP 80

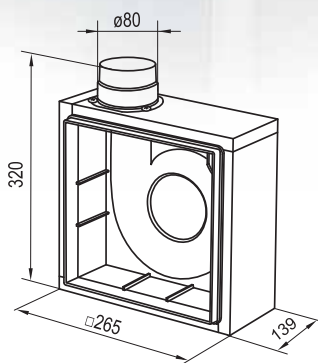

Description:

- intended for protection of the premises from penetration of fire and combustion products through the ventilation shafts during a fire.
- executed with unattended fire retarding valve and fire-resistant case for application in high-rise construction with increased requirements to fire prevention;
- made of silicate plates manufactured according to a special cement technique on basis of calcium silicate
- does not contain asbestos and possess high mechanical and insulation properties, and is hygroscopic and vapor permeable, that is why humidity is controlled by physical parameters of the material;
- installed into the wall during finishing works;
- connected with the main ventilation shaft with a flexible air duct;
- diameter of the connecting pipe is 80mm;
- fire-proof case for installation of fan unit VNV-1 80 allows to use the fan at increased fire-prevention requirements for construction of the multistory residential buildings;
- safety cover for protection of the case during finishing and painting works in the room;
- if executed for ventilation of two rooms it is equipped with additional pipes (three versions of connection) in the case for ventilation of the second room. In this case a set for exhaust ventilation of a second room is used.

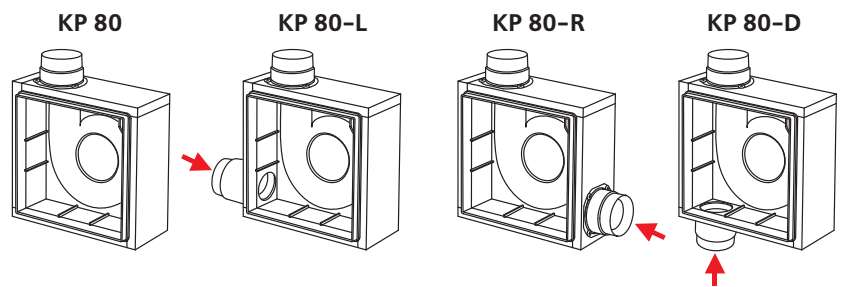

➔ Connecting of the air ducts for ventilation of a second room from the left (KP-80 L), the right (KP-80 R), from the bottom (KP-80 D)

Fire retarding valve

It is used to prevent the fire and smoke from distribution through the air ducts. When the temperature rises up to 90°C, the fusible element is activated and the valve automatically blocks the access of the hot air that prevents the distribution of fire and smoke through the ventilation shafts system. The valve plate is made of stainless steel. When the ventilator is switched off, it serves as a back valve that prevents the air overflow from the ventilation shaft.

Mount options:



Order code:

KP 80 Additional flange for ventilation of the second room

- - absent
- L - to the left
- R - to the right
- D - down

Accessories:

Spirovent Bracket Aluvent Termovent Fire retarding valve Clamp Kit for two rooms



See description and list of accessories on p. 14

PLASTIC CASE FOR THROUGH-THE-WALL MOUNTING KV 80

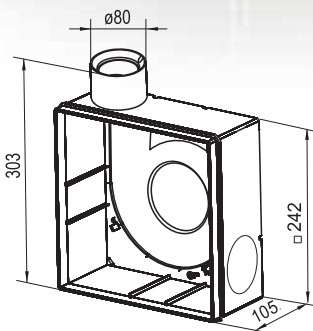

The correct placement of the back valve

ATTENTION!!!

When installing the case, make sure the back valve is placed correctly and it closes by gravity in the absence of airflow.

Description:

- installed into the wall during finishing works;
- is not fire-proof;
- made of high-quality and durable ABS plastic;
- equipped with a plastic roll over check valve;
- makes up a full delivery set together with the fan unit VNV-180;
- connected with the main ventilation shaft with a flexible air duct;
- diameter of the connecting pipe is 80mm;
- safety cover for protection of the case during finishing and painting works in the room;
- perforation in the case for connection of additional pipes for ventilation of a second room. In this case a set for exhaust ventilation of a second room is used. To connect an additional pipe it is necessary to remove the plug in the case.

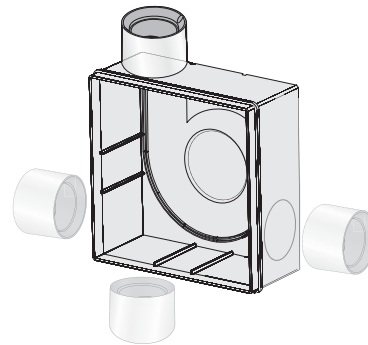

Options for connecting a pipe for ventilation of a second room

Mount options:



Order code: _____

KV 80

Accessories: _____

Spirovent Bracket Aluvent Termovent Pipe P80 Clamp Kit for two rooms



See description and list of accessories on p. 14

FAN IN THE FIREPROOF CASE VNV-1 80 KP

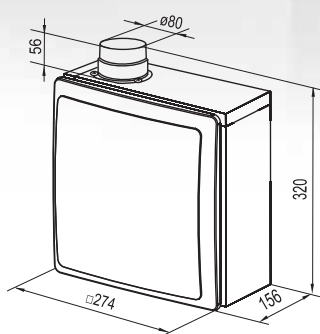

Description:

- intended for through-the-wall mounting;
- supplied in the fire-proof case KP 80;
- for periodical or continuous work;
- independently maintains pressure and air flow in the duct;
- economy efficient 2- or 3-speed motor with minimum energy consumption;
- fastened in the case with clips without the use of any additional tools;
- ball bearings increase the service life;
- front panel is made of high-quality and durable ABS plastic;
- turnable front cover conceals the drawbacks of installation of the fan case;
- to achieve precise characteristics, low noise level and safe operation each turbine of the fan undergoes dynamic balancing.



Application:

- in the ventilation systems of multifloor residential and public buildings;
- in the buildings with one-pipe ventilation system;
- mounted in kitchens, bathrooms, toilets, storerooms and other household rooms.

Specifications:

Model	VNV-1 80 KP	VNV-1A 80 KP	VNV-1B 80 KP	VNV-1C 80 KP	VNV-1D 80 KP
Number of speeds	3	2	2	3	2
Voltage, V (50 Hz)	220-240	220-240	220-240	220-240	220-240
Power consumption, W	17/27/48	12/17	12/27	12/17/27	17/27
Input current, A	0,14/0,18/0,21	0,12/0,14	0,12/0,18	0,12/0,14/0,18	0,14/0,18
Connection to power network, mm ²	4x1,5	3x1,5	3x1,5	4x1,5	3x1,5
Max. air consumption, m ³ /h	63/102/150	35/63	35/102	35/63/102	63/102
RPM	1350/1830/2640	890/1350	890/1830	890/1350/1830	1350/1830
Sound pressure level at distance of 3m, dBA	30/35,2/43,7	26,6/30	26,6/35,2	26,6/30/35,2	30/35,2
Max. temperature of the transported air, °C	50	50	50	50	50

See aerodynamic characteristics on page 7

Options of 2-speed fans:

- T – with a timer
- TR – with an adjustable timer
- I – with an interval switch
- F – with a photo sensor
- N – with a humidity sensor

Mount options:



Order code:

VNV-1	air capacity m ³ /h	80	case	options*
	A - 60/100/150;		KP	T
	B - 35/60;		KP-D	TR
	C - 35/100;		KP-L	I
	D - 35/60/100;		KP-R	F
				N

Accessories:



* Only for 2-speed fans

See description and list of accessories on p. 14

FAN IN THE PLASTIC CASE VNV-1 80 KV

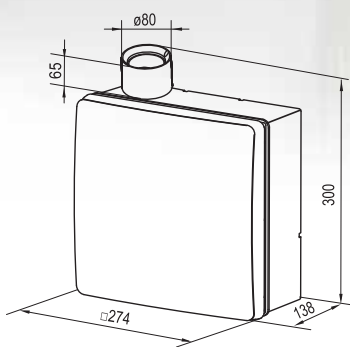

Description:

- intended for through-the-wall mounting;
- supplied in the plastic case KV 80;
- for periodical or continuous work;
- independently maintains pressure and air flow in the duct;
- economy efficient 2- or 3-speed motor with minimum energy consumption;
- ball bearings increase the service life;
- to achieve precise characteristics, low noise level and safe operation each turbine of the fan undergoes dynamic balancing; front panel is made of high-quality and durable ABS plastic;
- turnable front cover conceals the drawbacks of installation of the fan case;
- fastened in the case with clips without the use of any additional tools.



Application:

- in the ventilation systems of multistory residential and public buildings;
- in the buildings with one-pipe ventilation system;
- mounted in kitchens, bathrooms, toilets, storerooms and other household rooms.

Specifications:

Model	VNV-1 80 KV	VNV-1A 80 KV	VNV-1B 80 KV	VNV-1C 80 KV	VNV-1D 80 KV
Number of speeds	3	2	2	3	2
Voltage, V (50 Hz)	220-240	220-240	220-240	220-240	220-240
Power consumption, W	17/27/48	12/17	12/27	12/17/27	17/27
Input current, A	0,14/0,18/0,21	0,12/0,14	0,12/0,18	0,12/0,14/0,18	0,14/0,18
Connection to power network, mm ²	4x1,5	3x1,5	3x1,5	4x1,5	3x1,5
Max. air consumption, m ³ /h	63/102/150	35/63	35/102	35/63/102	63/102
RPM	1350/1830/2640	890/1350	890/1830	890/1350/1830	1350/1830
Sound pressure level at distance of 3m, dBA	30/35,2/43,7	26,6/30	26,6/35,2	26,6/30/35,2	30/35,2
Max. temperature of the transported air, °C	50	50	50	50	50

See aerodynamic characteristics on page 7

Options of 2-speed fans:

- T – with a timer
- TR – with an adjustable timer
- I – with an interval switch
- F – with a photo sensor
- N – with a humidity sensor

Mount options:



Order code:

VNV-1 air capacity m³/h 80 KV options*
 - 60/100/150; T
 A - 35/60; TR
 B - 35/100; I
 C - 35/60/100; F
 D - 60/100. N

Accessories:



* Only for 2-speed fans

See description and list of accessories on p. 14



VN-1 80

VN 80

Description:

- fans for wall mounting;
- consist of a outer case, turbine with suction box, front panel and roll over check valve;
- installed on the wall upon finishing works in the room;
- exhaust of air can be directly into ventilation shaft or through an air duct;
- diameter of the connecting pipe d = 80 mm.

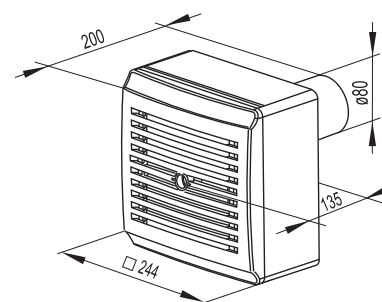
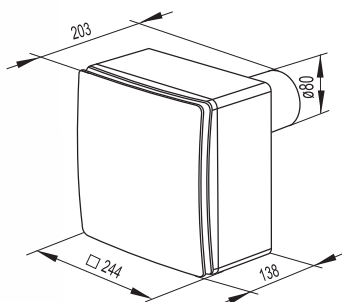

Mount options:

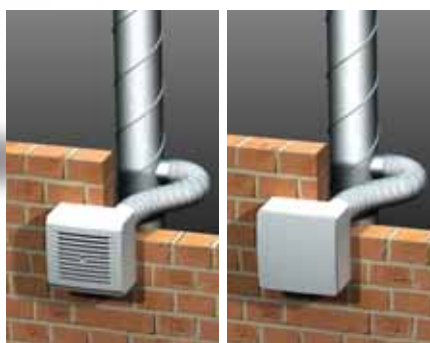

Options of 2-speed fans:

- T – with a timer
- TR – with an adjustable timer
- I – with an interval switch
- F – with a photo sensor
- N – with a humidity sensor

Specifications:

Model	VN-1 80 VN 80	VN-1A 80 VN-A 80	VN-1B 80 VN-B 80	VN-1C 80 VN-C 80	VN-1D 80 VN-D 80
Number of speeds	3	2	2	3	2
Voltage, V (50 Hz)	220-240	220-240	220-240	220-240	220-240
Power consumption, W	17/27/48	12/17	12/27	12/17/27	17/27
Input current, A	0,14/0,18/0,21	0,12/0,14	0,12/0,18	0,12/0,14/0,18	0,14/0,18
Connection to power network, mm ²	4x1,5	3x1,5	3x1,5	4x1,5	3x1,5
Max. air consumption, m ³ /h	63/102/150	35/63	35/102	35/63/102	63/102
RPM	1350/1830/2640	890/1350	890/1830	890/1350/1830	1350/1830
Sound pressure level at distance of 3m, dBA	30/35,2/43,7	26,6/30	26,6/35,2	26,6/30/35,2	30/35,2
Max. temperature of the transported air, °C	50	50	50	50	50

See aerodynamic characteristics on page 7

Order code:

VN

design of front cover	air capacity m ³ /h	80	options*
- plate	- 60/100/150; A - 35/60; B - 35/100; C - 35/60/100; D - 60/100.		T TR I F N
-1 - grille			

Accessories:

Спировент Термоvent Aluvent Door grilles Filter Speed switch Clamp



* Only for 2-speed fans

See description and list of accessories on p. 14

ADDITIONAL ADVANTAGES OF THE VENTILATOR VN

Convenient installation:



The ventilator's case (KP 80 or KV 80) is installed in the phase of civil and erection works and is connected to the main ventilation shaft. The electric wiring for the connection of the ventilation assembly (VNV 1-80) led through the special outlet in the case. To protect the case from dust and dirt, its facing part is closed with protective cover that is available with a package as well. After the repair works are completed, the protective cover may be removed and the ventilation assembly (VNV 1-80) is installed into the case, which is connected to the wiring.

Design of faceplate:



White



Natural aluminum



Metallic (grey)

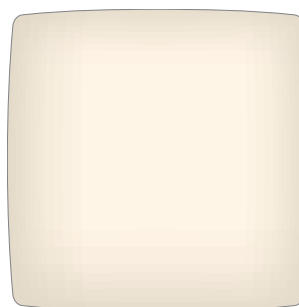

Beige



Decor A113*



Decor A127*



Decor A126*



Decor KR301*

* panels with decorative elements are available in such colours: white, beige, metallic (grey), or paintable in any colour with any damp-proof solvent-free paint.



Item		Description
	Flexible ducts Aluvent Ø80	System of flexible air ducts for intake and exhaust ventilation of household and commercial premises. Ducts are made of aluminum tape wound into a spiral and connected with a tight lock. Advantages: low weight, easy to cut with simple tools, increased tightness of seams, increased temperature and chemical resistance.
	Flexible ducts Thermovent Ø80	System of thermo-resistant flexible air ducts for intake and exhaust ventilation. Air ducts are made of stainless or galvanized steel, have increased thermo- and antirust resistance.
	Spirovent	System of spiral seam tubes for intake and exhaust ventilation. Made of galvanized steel, have increased rigidity.
	Clamp Ø80	Used for fastening the flexible air ducts to a fan. Made of stainless steel and have high antirust resistance. Equipped with an easy lock mechanism made of galvanized steel.
	Speed switch P2-1-300 and P3-1-300	Used with 3-speed motors for regulating the fan speed and selecting an optimal operation mode.
	Speed switch P2-5.0 and P3-5.0	Used with 2-speed motors for regulating the fan speed and selecting an optimal operation mode.
	Pipe P80	Intended for connecting the air ducts coming from a second room to the plastic case KV 80.
	Door ventilation screens MV	Intended for use in the internal residential and commercial rooms. Mounted in a door for free circulation of air between the rooms. Made of high-quality plastic or metal and are made in different dimensions and colors.
	Fire-retarding valve PL 16	Fire-retarding valve prevents penetration of smoke and fire through the air ducts of ventilation and air conditioning systems during a fire. Mounted in the ducts of ventilation channels that come through fireproof walls and ceilings. Dimension range is from Ø 100 to Ø 500mm.
	Air filter	Serves to protect the motor and impeller from penetration of contaminants present in the air. Filter element is made of polyether. Purification class is G4.
	Window vent PO400	Sound-proof passive intake element for mounting into window frames. Highly efficient intake of fresh air with the closed window. Smooth regulation of air consumption.
	Wall vent PS 100, PS 101, PS 102	Mechanically intake element for intake ventilation. Mounted into the external wall of a building. Ensures filtration of the intake air. The built-in regulator allows to change the intake air volume or to close the ventilation duct completely.
	Plastic reducer 110	For reducing from Ø 80 to Ø 100
	Bracket	Mounting bracket for fixing the fan cases to walls and ceilings. Design of the bracket allows to secure high reliability and comfortable use. Made with oblong slots for more accurate leveling of the fan case. Used with cases KP 80 and KV 80.
	Roof fan VKG/VKV	Mounted on the roof and is designed for exhaust of air from the ventilation system.
	Set for two rooms	Used for arranging the ventilation system of two rooms with one fan. Consists of the screen MV 100V, air duct Aluvent 80/3, reducer 110 and pipe P80 (only for plastic case KV 80).

FIRE-RETARDING VALVE PL 16

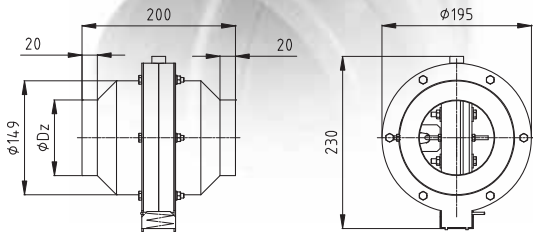

Size 100 and 125 with adaptors

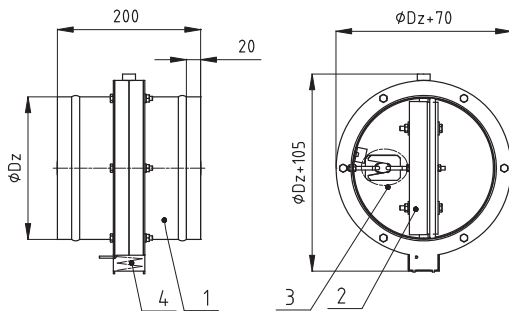

Size 150-500

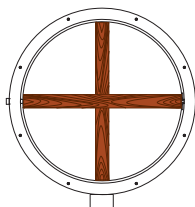
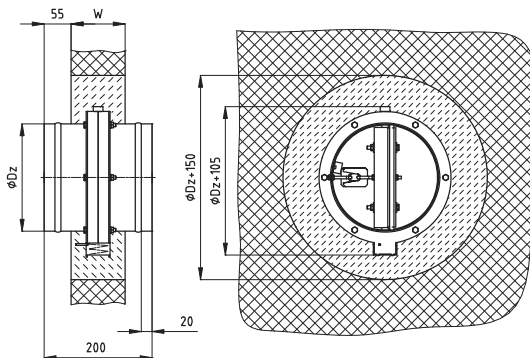

Use of wooden supports during mounting

Application:

Fire-retarding valve prevents penetration of smoke and fire through the air ducts of ventilation and air conditioning systems during a fire. Mounted in the ducts of ventilation channels that come through the fireproof walls and ceilings.

Design:

Made of a galvanized steel case (1), blade from insulation material (2), thermic release mechanism (3) activated at 70°C and spring (4).

The fire-retarding valve is open in the working position. In case of a fire the thermoelement will melt at 70°C and the spring will move the blade to the closed position.

Dimensions:

$\phi Dz = 100^*, 125^*, 150, 160, 180, 200, 224, 250, 280, 300, 315, 350, 355, 400, 500$ mm

* - Sizes 100 and 125 have adaptors

Mounting:

Fire-retarding valve is always installed so that the release mechanism and locating hole are at the easy to access side of the wall or ceiling. Thus, easy inspection of thermic release mechanism and its internal part is ensured.

It is possible to build the valve into brick and concrete walls or gypsum plates of the relevant fire endurance. Minimum allowable thickness of a wall or ceiling is $W=10$ cm. To preserve the shape during the mounting works it is recommended to use wooden supports that prevent deformation of the case. Wooden supports should be removed after the final mounting.

Warning:

Fire-retarding valves shall not be installed in the rooms with a danger of explosion as well as in the ventilation systems intended for exhaust of air and explosive gas mixture.

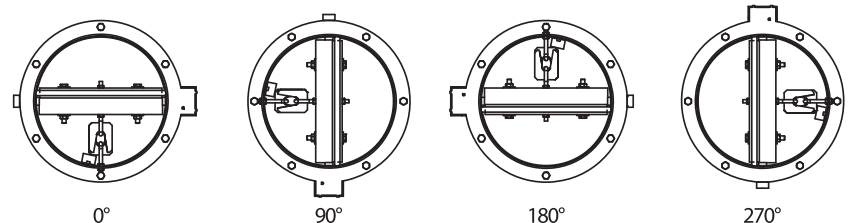

Recommended positions of the fire-retarding valve

Order code: _____

PL 16 EI 120 A4 FI

DESIGN OF VENTILATION SHAFTS IN MULTISTOREY BUILDINGS

The dependence of ventilation shaft size on the number of storeys in the multistorey buildings with single-pipe ventilation system.

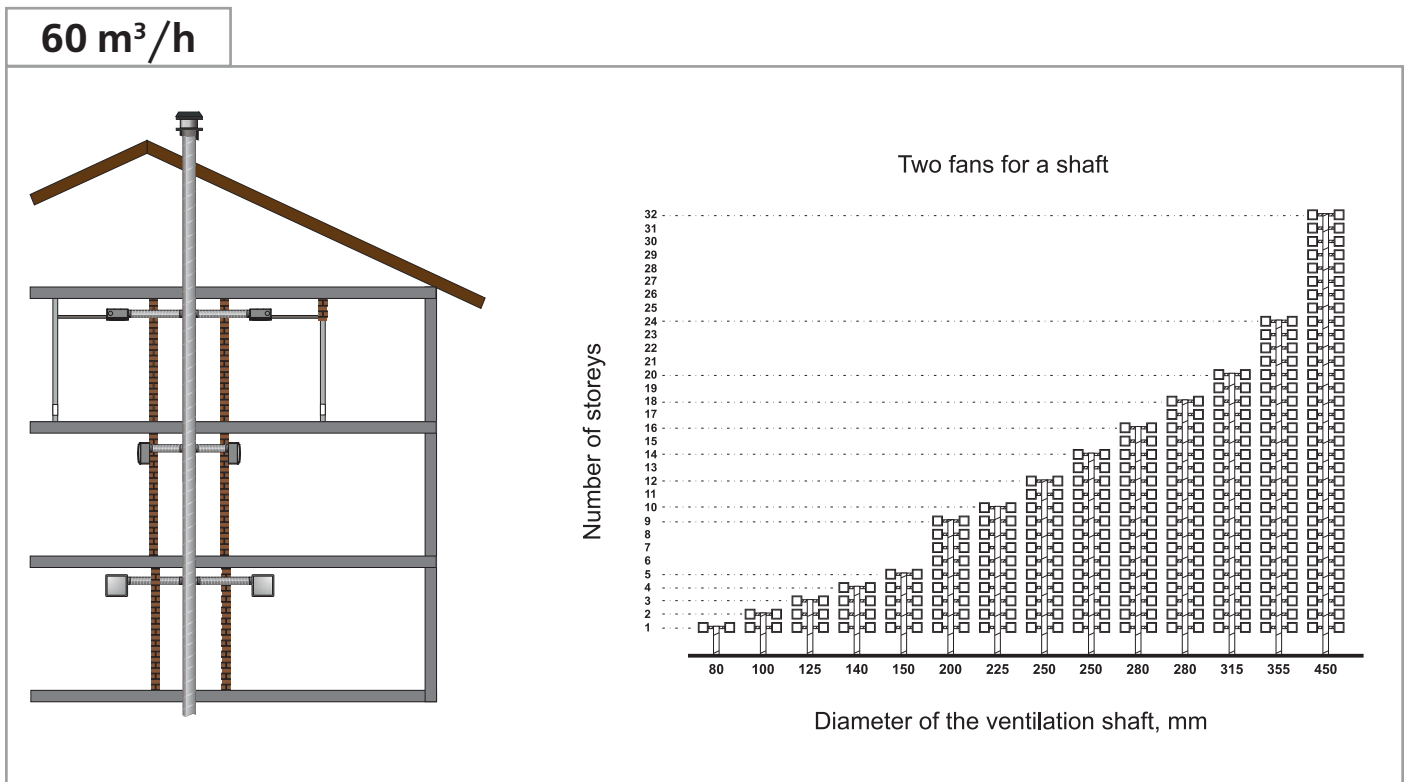
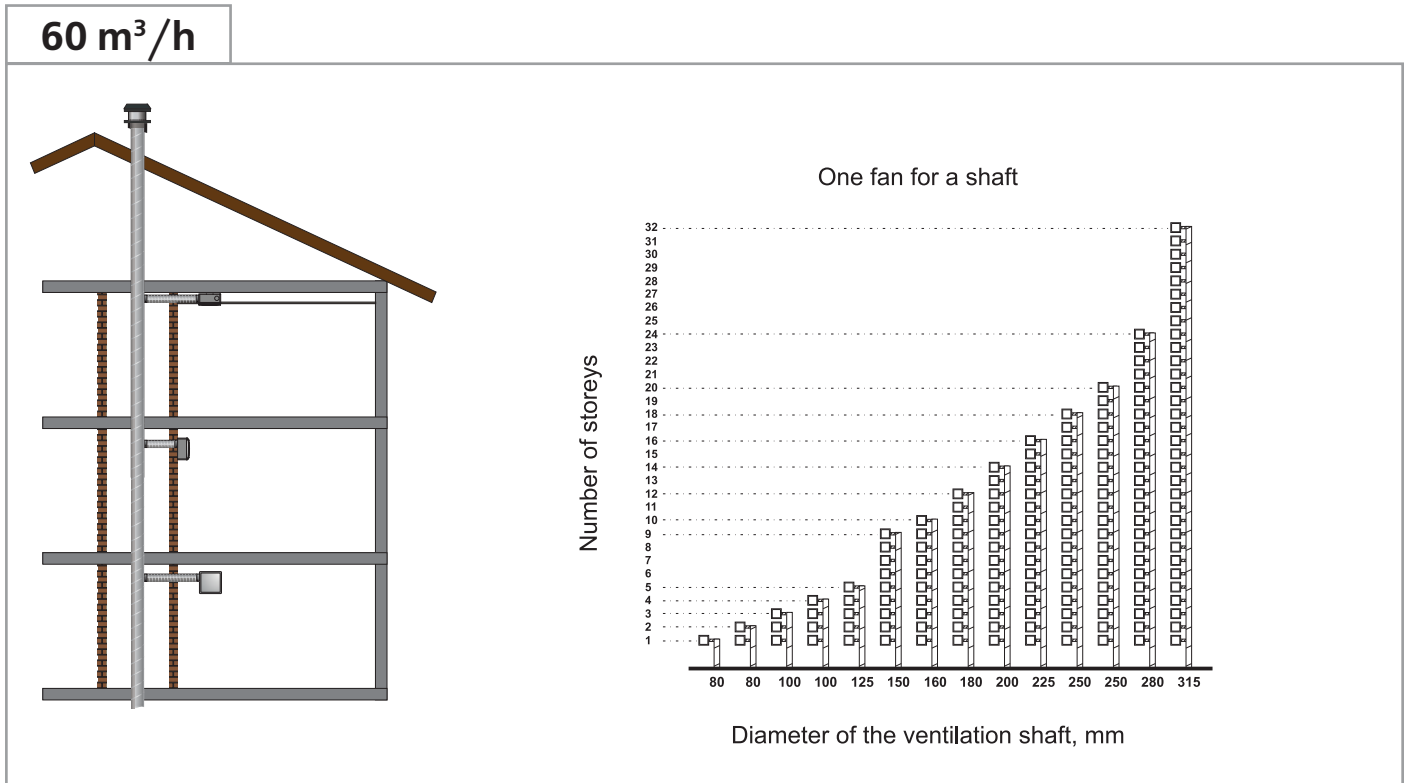

DESIGN OF VENTILATION SHAFTS IN MULTISTOREY BUILDINGS

100 m³/h

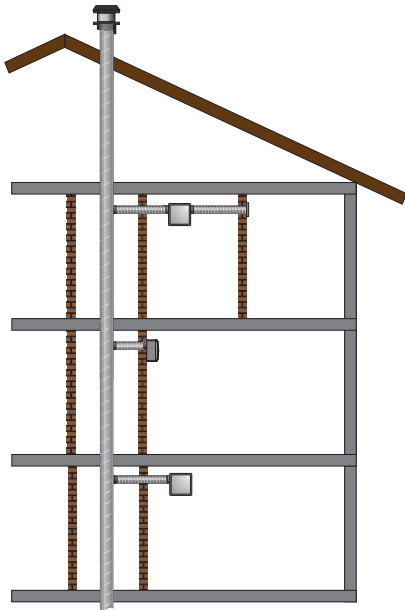

One fan for a shaft

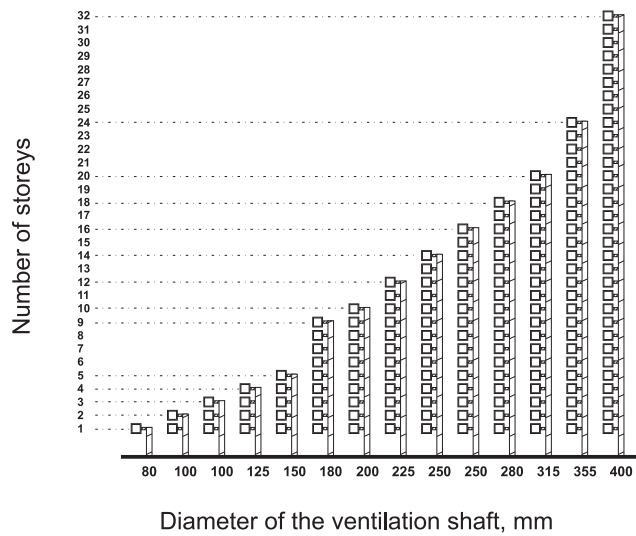

100 m³/h

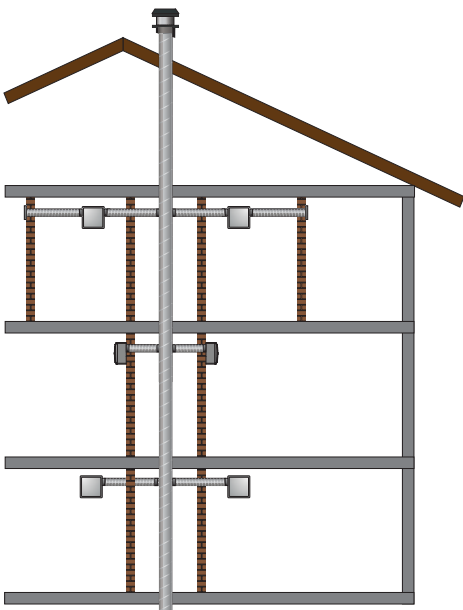

Two fans for a shaft

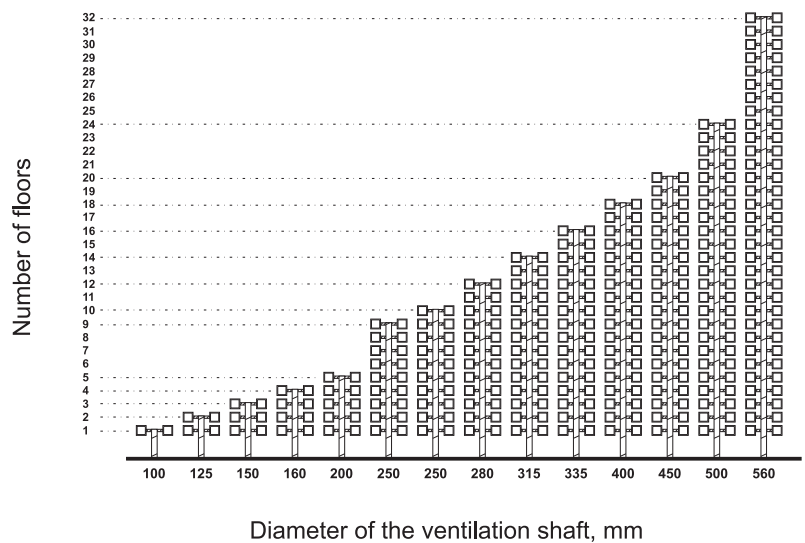

Connection of base three-speed models of fans

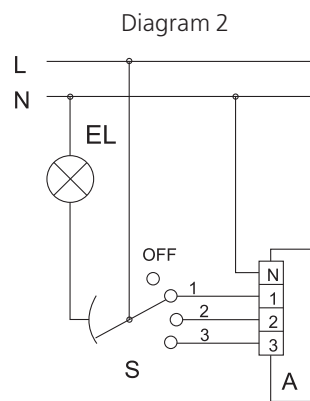
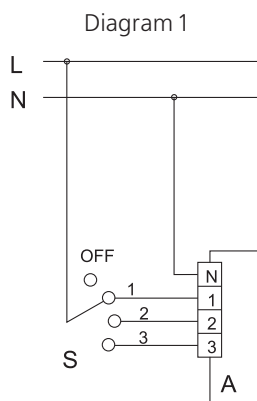

VNV-1 80
VNV-1 80 KP
VNV-1 80 KV
VN-1 80
VN 80

VNV-1C 80
VNV-1C 80 KP
VNV-1C 80 KV
VN-1C 80
VN-C 80

Fan can be switched on to one of three speeds manually with an external speed switch S (e.g. P3-1-300) or switched off.

Fan can be switched on to one of three speeds manually with an external speed switch S (e.g. P3-1-300) with parallel turning on the light in the room or switched off with parallel tuning off the light in the room. The fan cannot be switched on without turning on the light and vice versa.

Connection of base two-speed models of fans

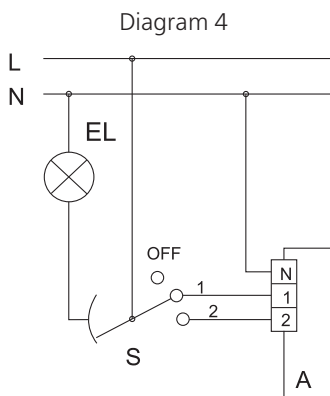
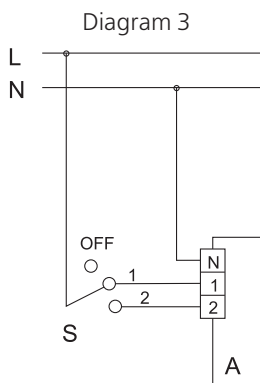

VNV-1(A,B,D) 80
VNV-1(A,B,D) 80 KP
VNV-1(A,B,D) 80 KV
VN-1(A,B,D) 80
VN-(A,B,D) 80

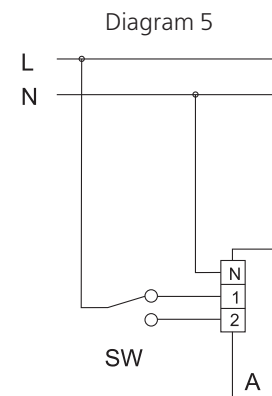

Fan can be switched on to one of two speeds manually with an external speed switch S (e.g. P3-1-300) or switched off. Positions "2" and "3" activate only the second speed of the fan.

Fan can be switched on to one of two speeds manually with an external speed switch S (e.g. P3-1-300) with parallel turning on the light in the room or switched off with parallel tuning off the light in the room. The fan cannot be switched on without turning on the light and vice versa. Positions "2" and "3" activate only the second speed of the fan.

Fan runs constantly at the first or second speed. Speed change is made with a switch SW.



Connection of base two-speed models of fans with timer (T), regulated timer (RT) or interval switcher (I).

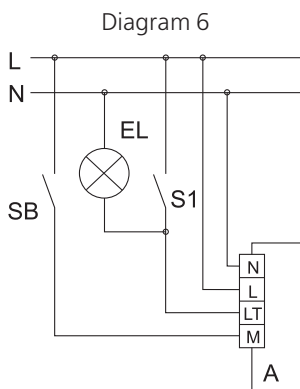

With a timer (T) or adjustable timer (TR):

Fan with a T, TR option runs constantly at the first speed with the closed SB switch or is switched off when the switch is open. The fan can be switched on to the second speed manually with the S1 switch with parallel turning on the light in the room. Turn-on delay time for the second speed then will be 50 seconds for the T option and from 0 to 150 seconds for the TR option. After switching off the S1 the light in the room will be turned off, but the fan will keep running for the time set by the timer: 6 minutes for T, 2-30 minutes for TR, then will change automatically to the first speed and will be switched off.

With an interval switch (I):

Fan with an interval switch (I) runs constantly at the first speed with the closed SB switch or is switched off when the switch is open. The fan periodically changes to the second speed during the interval from 0.5 to 15 hours set manually. Working time at the second speed is 10 minutes. The fan can be switched on to the second speed manually with a S1 switch with parallel turning on the light. Turn-on delay time for the second speed then will be 50 seconds. After switching off the S1 the light in the room will be turned off, and the fan will come back to the interval mode of operation.

VNV-1(A,B,D) 80 (T, TR, I)
VNV-1(A,B,D) 80 KP (T, TR, I)
VNV-1(A,B,D) 80 KV (T, TR, I)
VN-1(A,B,D) 80 (T, TR, I)
VN-(A,B,D) 80 (T, TR, I)



Connection of two-speed models of fans with photoelectronics (PH)

Diagram 7

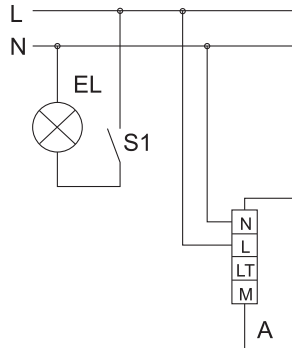

In the starting position the fan is switched off. When the light is turned on in the room, the fan starts to work at the second speed with the help of a photo sensor. Turn-on delay time for the second speed is 50 seconds. After tuning off the light, the fan will keep running for the time set by the timer from 2 to 30 minutes, and then will switch off automatically. The first speed is not engaged in this scheme.

Diagram 8

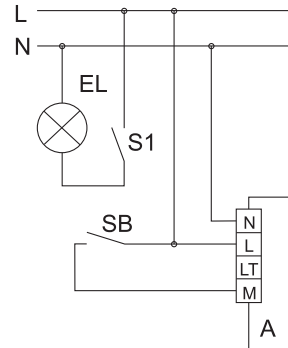

Fan runs constantly at the first speed with the closed SB switch or is switched off if the switch is open. When the light is turned on in the room, the fan starts to work at the second speed with the help of a photo sensor. Turn-on delay time for the second speed is 50 seconds. After tuning off the light, the fan will keep running for the time set by the timer from 2 to 30 minutes, and then will switch automatically to the first speed or will switch off.

VNV-1 (A,B,D) 80 F
 VNV-1 (A,B,D) 80 KP F
 VNV-1 (A,B,D) 80 KV F
 VN-1 (A,B,D) 80 F
 VN-(A,B,D) 80 F



Connection of two-speed models of fans with humidity sensor (H)

Diagram 9

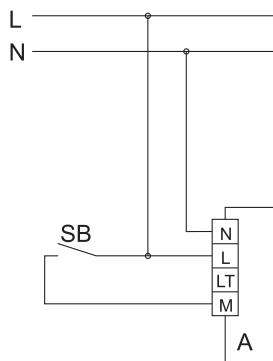

Fan runs at the first speed with the closed switch SB or is switched off if the switch is open. When the relative humidity level in the room is increased, the fan automatically switches on to the second speed and will run so till the humidity level drops to the required value.

Diagram 10

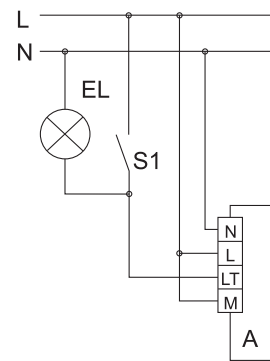

Fan runs constantly at the first speed. When the relative humidity level in the room is increased, the fan automatically switches on to the second speed and will run so till the humidity level drops to the required value. Additionally, the fan can be switched on to the second speed or switched off manually with a S1 switch parallel with the light in the room. Turn-on delay time for the second speed is 50 seconds.

VNV-1 (A,B,D) 80 N
 VNV-1 (A,B,D) 80 KP N
 VNV-1 (A,B,D) 80 KV N
 VN-1 (A,B,D) 80 N
 VN-(A,B,D) 80 N

Diagram 11

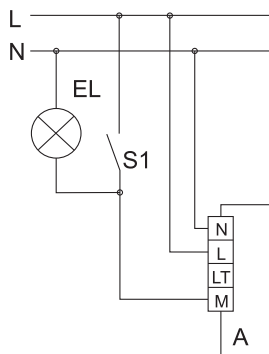

Fan runs at the first speed, if the light in the room is turned on (with a switch S1), or is switched off if the light is turned off. When the relative humidity level in the room is increased, the fan automatically switches to the second speed and will run so till humidity level drops to the required value regardless of the S1 position.

Diagram 12

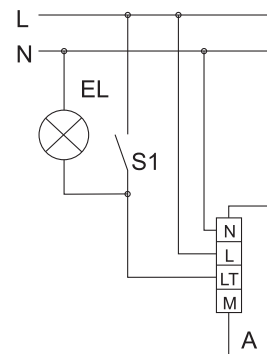

In the starting position the fan is switched off. When the relative humidity level in the room is increased, the fan automatically switches to the second speed and will run so till the humidity level drops to the required value. Additionally the fan can be switched on to the second speed manually with the S1 switch or switched off parallel with the light in the room. Turn-on delay time for the second speed is 50 seconds. The first speed is not engaged in this scheme.

VENTILATION SYSTEM ARRANGEMENT EXAMPLE

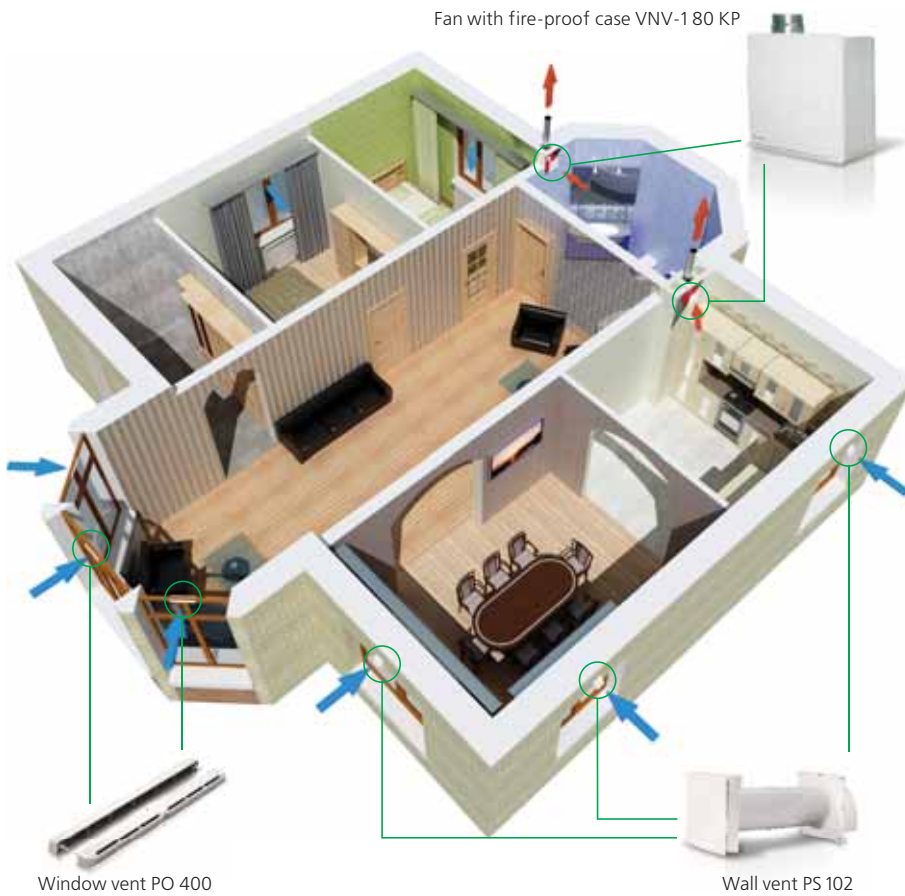

In modern residential buildings special attention shall be paid to the arrangement of air exchange. Problems with ventilation that arise during the application of airproof windows cannot be solved using the old technical means intended for the inflow of the outer air through the numerous chinks in the windows. Whatever the section of the kitchen or bathroom exhaust duct may be, there would be no air current if its flow from outside would not be arranged.

In the town apartment of the multistorey domestic building the ventilation can be arranged following such an example. The mechanical exhaust ventilation systems with the natural air flow are designed with the exhaust ventilators that are installed in the kitchen, bathroom and toilet. The air flows in through the window or wall conditioners. The clean air comes into the living spaces of the apartment (bedroom, living room). As the air is polluted, it comes through the inner doors to the bathroom, toilet and kitchen, where it is removed by exhaust ventilators.

1. Fan with fire-proof case VNV series for in-build mounting
2. Fan with plastic case VNV series for in-build mounting
3. Fan VN series for the wall mounting
4. Roof fan VKH (VKV) series
5. Ventilation grilles MV series
6. Wall vent PS 100, PS 101, PS 102
7. Door grilles MV 430/2, MV 450/2
8. Window vent PO 400
9. Air ducts Spirovent
10. Air ducts Aluvent (Termovent)
11. Fire-retarding valve PL 16

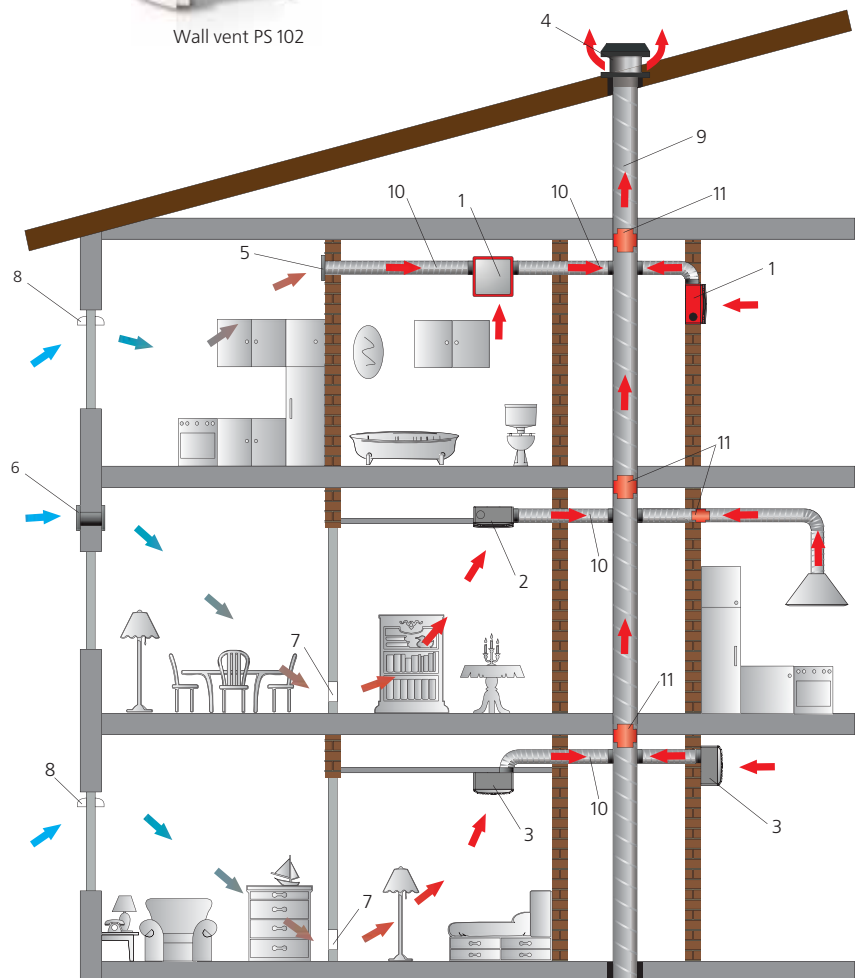





VENTS reserves the right to make any changes caused by production necessity without further notice

English

02/2010