

USER'S MANUAL

TwinFresh Atmo
TwinFresh Atmo M
TwinFresh Atmo C1
TwinFresh Atmo C1 M

TwinFresh Atmo mini
TwinFresh Atmo mini M



Single-room reversible energy recovery ventilator

CONTENTS

Safety requirements.....	2
Purpose.....	4
Delivery set.....	4
Designation key.....	4
Technical data.....	5
Design and operating principle.....	6
Mounting and set-up.....	9
Connection to power mains.....	14
Technical maintenance.....	19
Storage and transportation regulations.....	21
Manufacturer's warranty.....	22
Certificate of acceptance.....	23
Seller information.....	23
Installation certificate.....	23
Warranty card.....	23

This user's manual is a main operating document intended for technical, maintenance, and operating staff.

The manual contains information about purpose, technical details, operating principle, design, and installation of the Atmo (mini) (C1) (M) unit and all its modifications.

Technical and maintenance staff must have theoretical and practical training in the field of ventilation systems and should be able to work in accordance with workplace safety rules as well as construction norms and standards applicable in the territory of the country.

SAFETY REQUIREMENTS

This unit is not intended for use by persons (including children) with reduced physical, sensory or mental capabilities, or lack of experience and knowledge, unless they have been given supervision or instruction concerning use of the unit by a person responsible for their safety. Children should be supervised to ensure that they do not play with the unit.

This appliance can be used by children aged from 8 years and above and persons with reduced physical, sensory or mental capabilities or lack of experience and knowledge if they have been given supervision or instruction concerning use of the appliance in a safe way and understand the hazards involved.

Cleaning and user maintenance shall not be made by children without supervision.

Children shall not play with the appliance.

Connection to the mains must be made through a disconnecting device, which is integrated into the fixed wiring system in accordance with the wiring rules for design of electrical units, and has a contact separation in all poles that allows for full disconnection under overvoltage category III conditions.

If the supply cord is damaged, it must be replaced by the manufacturer, its service agent, or similarly qualified persons in order to avoid a safety hazard.

Ensure that the unit is switched off from the supply mains before removing the guard.

Precautions must be taken to avoid the back-flow of gases into the room from the open flue of gas or other fuel-burning appliances.

All operations described in this manual must be performed by qualified personnel only, properly trained and qualified to install, make electrical connections and maintain ventilation units.

Do not attempt to install the product, connect it to the mains, or perform maintenance yourself. This is unsafe and impossible without special knowledge.

Disconnect the power supply prior to any operations with the unit.

All user's manual requirements as well as the provisions of all the applicable local and national construction, electrical, and technical norms and standards must be observed when installing and operating the unit.

Disconnect the unit from the power supply prior to any connection, servicing, maintenance, and repair operations.

Connection of the unit to power mains is allowed by a qualified electrician with a work permit for the electric units up to 1000 V after careful reading of the present user's manual.

Check the unit for any visible damage of the impeller, the casing, and the grille before starting installation. The casing internals must be free of any foreign objects that can damage the impeller blades.

While mounting the unit, avoid compression of the casing! Deformation of the casing may result in motor jam and excessive noise.

Misuse of the unit and any unauthorised modifications are not allowed.

Do not expose the unit to adverse atmospheric agents (rain, sun, etc.).

Transported air must not contain any dust or other solid impurities, sticky substances, or fibrous materials.

Do not use the unit in a hazardous or explosive environment containing spirits, gasoline, insecticides, etc.

Do not close or block the intake or extract vents in order to ensure the efficient air flow.

Do not sit on the unit and do not put objects on it.

The information in this user's manual was correct at the time of the document's preparation.

The Company reserves the right to modify the technical characteristics, design, or configuration of its products at any time in order to incorporate the latest technological developments.

Never touch the unit with wet or damp hands.

Never touch the unit when barefoot.

BEFORE INSTALLING ADDITIONAL EXTERNAL DEVICES, READ THE RELEVANT USER MANUALS.



THE PRODUCT MUST BE DISPOSED SEPARATELY AT THE END OF ITS SERVICE LIFE.

DO NOT DISPOSE THE UNIT AS UNSORTED DOMESTIC WASTE.

PURPOSE

The ventilator is designed to ensure continuous mechanical air exchange in flats, cottages, hotels, cafés and other domestic and public premises. The ventilator is equipped with a regenerator that enables supply of fresh filtered air heated by means of extract air heat energy recovery.

The ventilator is designed for installation on external walls.

The ventilator is rated for continuous operation.

DELIVERY SET

Name	Number	
	TwinFresh Atmo mini TwinFresh Atmo mini M	TwinFresh Atmo TwinFresh Atmo M TwinFresh Atmo C1 TwinFresh Atmo C1 M
Indoor unit of the ventilator	1 pc.	1 pc.
Air duct	1 pc.	1 pc.
Silencer	1 pc.	1 pc.
Fan assembly	–	1 pc.
Heat recovery unit assembly	–	1 pc.
Assembled cartridge	1 pc.	–
Outer ventilation hood	1 pc.	1 pc.
Remote control	1 pc.	1 pc.
Cardboard template	1 pc.	1 pc.
Mounting kit	2 packs	2 packs
Mounting wedges	1 set	1 set
User's manual	1 pc.	1 pc.
Mounting hood installation instruction	1 pc.	1 pc.
Packing box	1 pc.	1 pc.

DESIGNATION KEY

TwinFresh Atmo C1 L07 M

Availability of shutters

– – shutters are available, they open and close only automatically

M – no shutters, the airflow can only be blocked manually using the front panel

Air duct length

– – 500 mm

L03 – 300 mm

L035 – 350 mm

L07 – 700 mm

Regenerator modification

– – standard regenerator

C1 – shortened regenerator

Ventilator series

TwinFresh Atmo – a series of reversible ventilators with a duct diameter of 160 mm and a nominal capacity of 50 m³/h

TwinFresh Atmo mini – a series of reversible ventilators with a duct diameter of 100 mm and a nominal capacity of 25 m³/h

TECHNICAL DATA

The temperature in the room where the indoor unit of the ventilator is installed must be in the range from +1 °C to +40 °C with relative humidity up to 65 % (no condensation build-up).

The temperature of the transported air should be in the range from -15 °C to +40 °C.

If the conditions of use of the ventilator are outside the specified limits, turn off the ventilator. Provide fresh air supply through windows.

The unit is rated as a class II electric appliance.

Ingress protection rating against access to hazardous parts and water ingress is IP24.

The type of hood supplied and the length of the duct depend on the model of the ventilator (see section Designation Key).

The unit design is constantly being improved, thus some models may be slightly different from those described in this manual.



OVERALL DIMENSIONS OF THE INDOOR UNIT [MM]

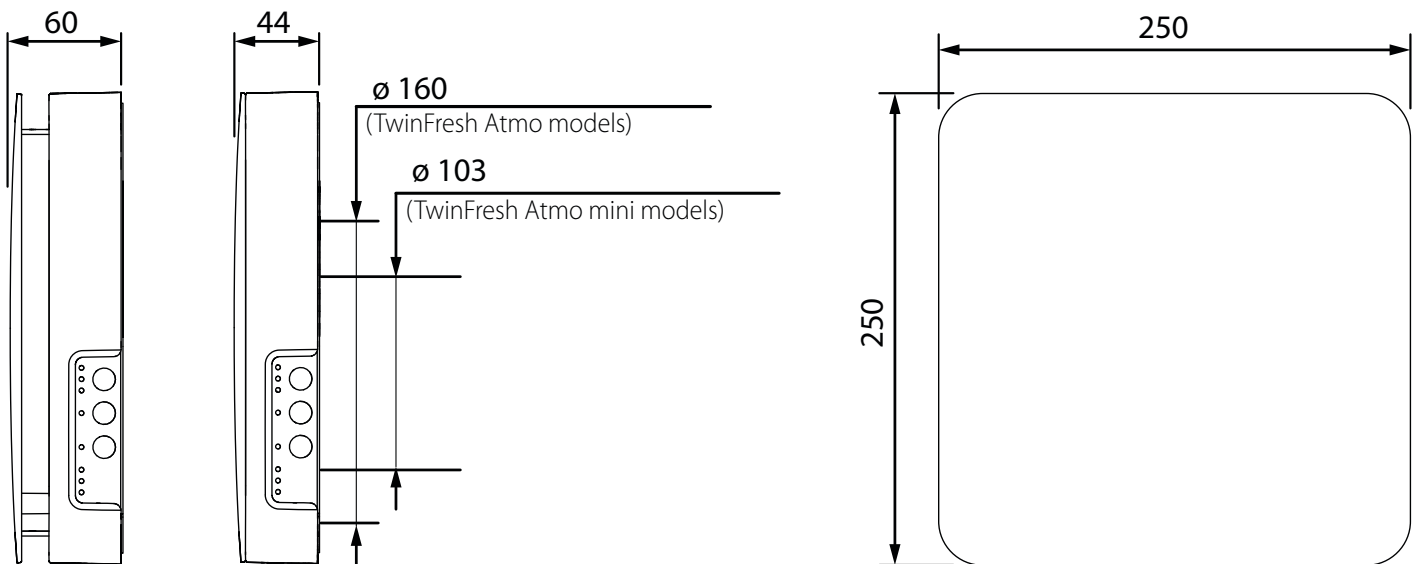

DESIGN AND OPERATING PRINCIPLE

The ventilator consists of an indoor unit with a decorative front panel, a fan unit, a heat exchanger unit, located inside the air duct and the outer ventilation hood.

In the **TwinFresh Atmo mini** and **TwinFresh Atmo mini M** models, the fan and heat exchanger units are combined in a single cartridge. Two filters are located inside the air duct in the airflow path to provide coarse air purification and prevent dust and foreign objects from entering the heat exchanger and the fan.

In the bottom right corner of the front panel of the ventilator, there is a window for the IR remote control receiver combined with a light sensor. The light sensor controls the brightness of the control panel LEDs.

The LEDs glow brighter during daylight hours and dimmer in the dark.

VENTILATOR DESIGN

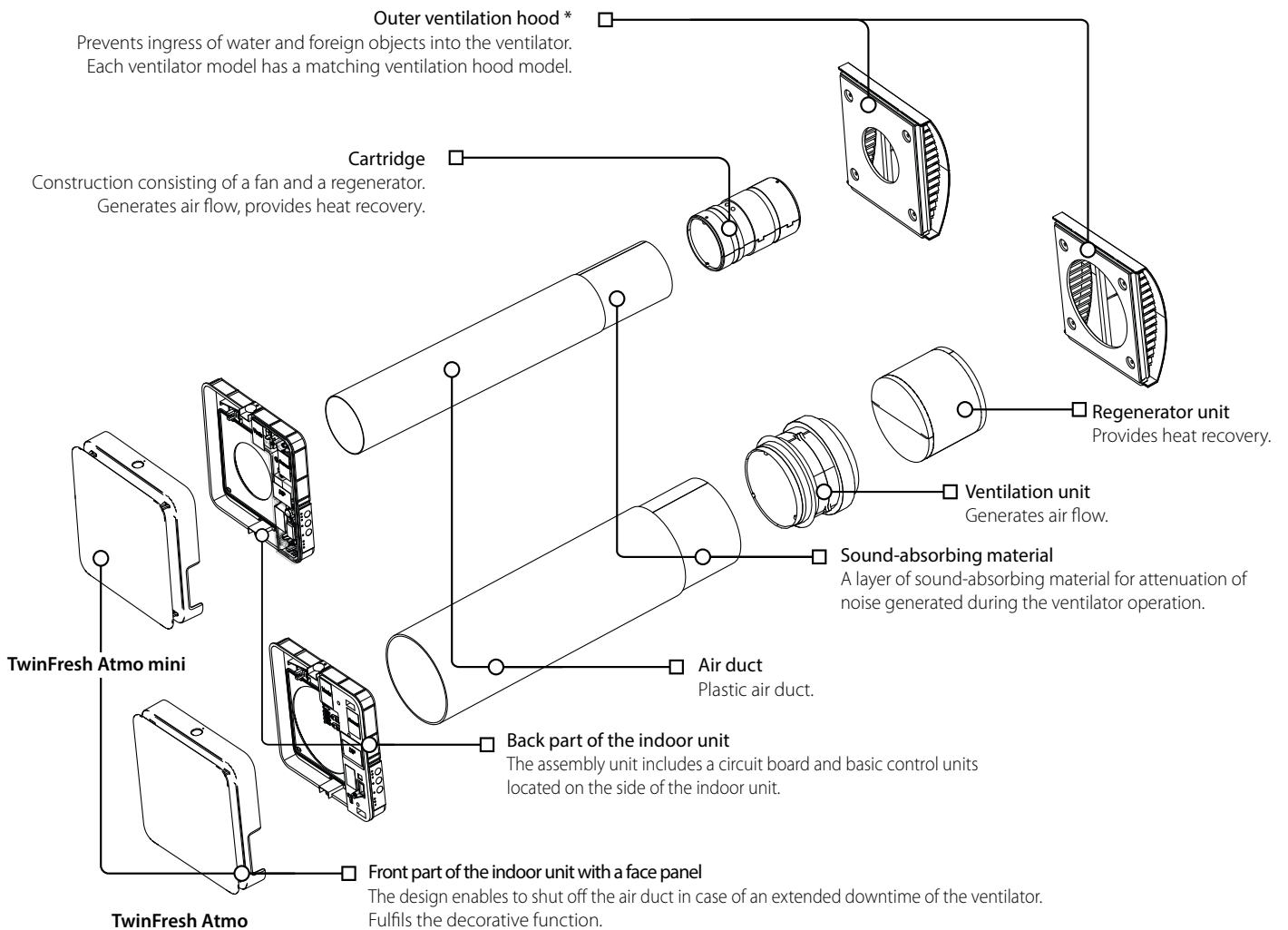

* in all pictures of this manual, an EH-14 hood is depicted as an example; the ventilator may be delivered with different hood models.

Operating principle of TwinFresh Atmo, TwinFresh Atmo C1 and TwinFresh Atmo mini ventilator shutters

The indoor unit is equipped with automatic shutters. During the ventilator operation the automatic shutters are opened and let the air flow freely through the ventilator. It takes 2 minutes for the shutters to close upon ventilator shutdown.

The process of opening and closing the shutter can take up to five minutes.

Attention! The unit is equipped with a shutter fixer (pos. 1). In the event of a power failure, the product shuts down but the shutters remain open.

If necessary, you can close the shutters. To do this, remove the front cover and press the push rod (item 2) in the direction of the arrow. This releases the push rod and the shutters close.

The product is equipped with a shutter position sensor. When power is restored, the sensor detects the position of the shutters and opens them if the product has been running or closes them if the product has not been running.

The shutter opening/closing mechanism operates with a delay of 1 to 5 minutes after the unit is switched on or off.

The indoor unit of the **TwinFresh Atmo M** and **TwinFresh Atmo C1 M** ventilators does not have shutters. The air duct in these models can only be blocked by pushing the front panel of the ventilator as far as it will go, as shown in the figure below.

The figure below shows the position of the shutters in the closed and open positions.

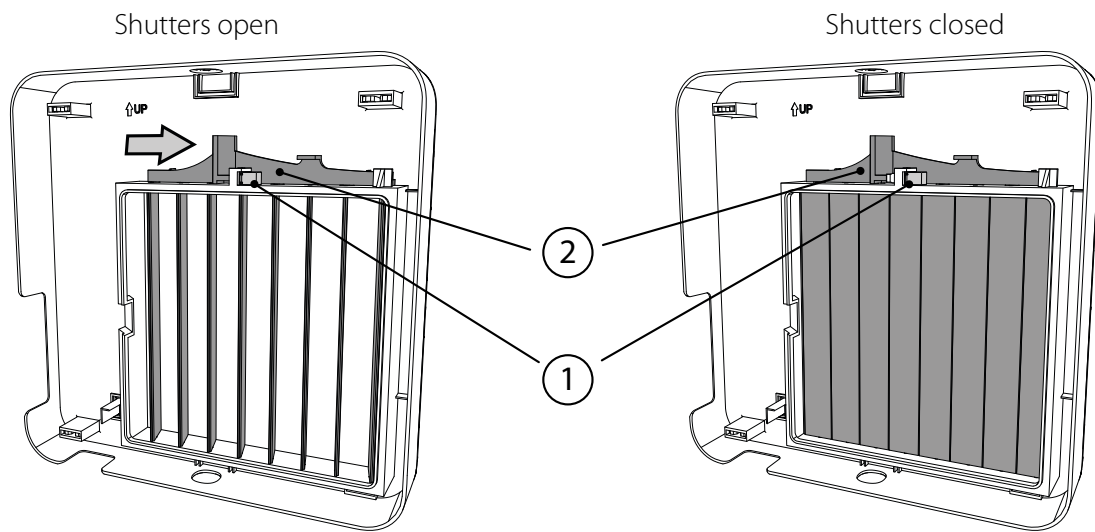

Opening/closing the airflow

To open the air duct, gently pull the front panel towards you with both hands. The ventilator's fan will automatically be set to the speed of the current ventilation mode.

To close the air duct, gently press down on the front panel until the air duct is completely closed. The ventilator's fan will turn off automatically. The function of the ventilator is not impacted during the procedure.

Opening the air duct

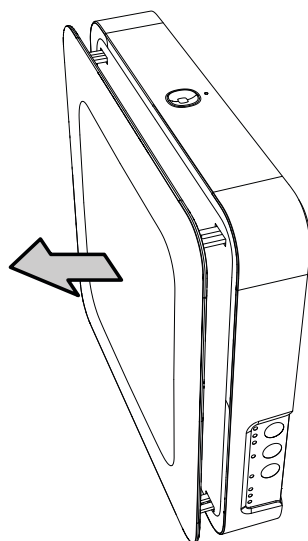

Closing the air duct

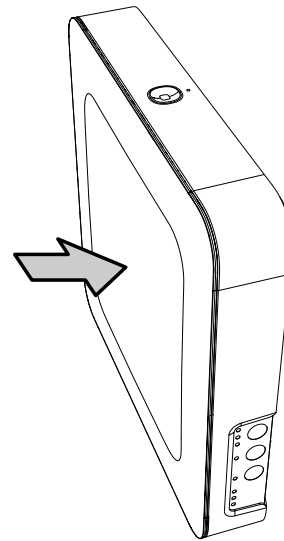

VENTILATOR OPERATION MODES

Ventilation: the ventilator runs either in air extraction or air supply mode at a set speed.

In this mode some of the ventilators in the network run in air supply mode and the other ones in air extraction mode, depending on the DIP switch No. 3 position (see "**Setting ventilator operation modes using DIP switches**").

Boost – if the set humidity level is exceeded or the NO-contact of the external relay sensor is closed, the ventilator switches to the third speed until the sensors switch to their standard status and the Boost turn-off timer runs out.

Regeneration: the ventilator runs in two cycles, 70 seconds each, with heat and humidity regeneration.

Cycle I. Warm stale air is extracted from the room and flows through the ceramic regenerator, which gradually absorbs heat and humidity. In 70 seconds, as the ceramic regenerator gets warmed, the ventilator is switched to air supply mode.

Cycle II. Fresh intake air from outside flows through the ceramic regenerator, absorbs accumulated moisture and is heated up to the room temperature. In 70 seconds, as the ceramic regenerator gets cooled down, the ventilator is switched to air extraction mode and the cycle is renewed.

The starting interval of a specific ventilator depends on the position of the DIP switch No. 3. If two ventilators - an even number of them - are installed, they must be set to operate with opposite rotation directions. While one ventilator supplies air, the other one extracts it.

When simultaneously activating several operation modes that exclude each other, the ventilator selects the mode according to the following priority:

1. Night mode timer or the Party mode timer
2. Standby
3. Boost
4. Standard operation mode

MOUNTING AND SET-UP



READ THE USER'S MANUAL BEFORE INSTALLING THE UNIT



DO NOT BLOCK THE AIR DUCT OF THE INSTALLED VENTILATOR WITH DUST ACCUMULATING MATERIALS, SUCH AS CURTAINS, CLOTH SHUTTERS, ETC. AS IT PREVENTS AIR CIRCULATION IN THE ROOM.

The figure below shows a schematic layout of the ventilator's internal elements depending on the wall thickness. The ability to mount the ventilator in the wall depends on the length of the internal elements and the required protrusion A.

The length of the internal elements, the diameter of the required opening and the minimum wall thickness in which the ventilator can be installed when using different external ventilation hoods are shown in the table below.

Layout of the ventilator units inside the wall

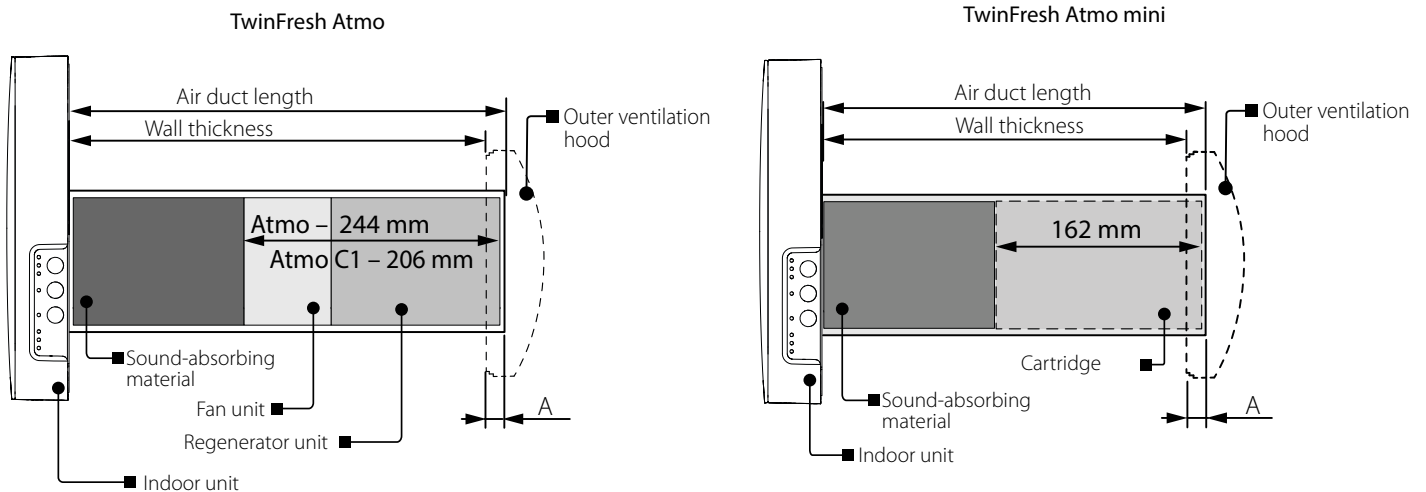

Reference dimensions for installation of ventilators	TwinFresh Atmo mini TwinFresh Atmo mini M	TwinFresh Atmo TwinFresh Atmo M	TwinFresh Atmo C1 TwinFresh Atmo C1 M
Hole diameter D [mm]	120	180	180
Length of cartridge or fan and regenerator units [mm]	162	244	206
Minimum possible wall thickness when using AH, EH-14, EH-13, EH-17, MVVM-160, hoods [mm]	from 152	from 234	from 196
Minimum possible wall thickness when using an EH-2, hood [mm]	from 52	from 134	from 96

1. Prepare a round core hole in the outer wall.

The figure below shows the minimum distance from the hole to the surrounding objects.

The hole diameter depends on the specific ventilator model. The corresponding values are given in the table.

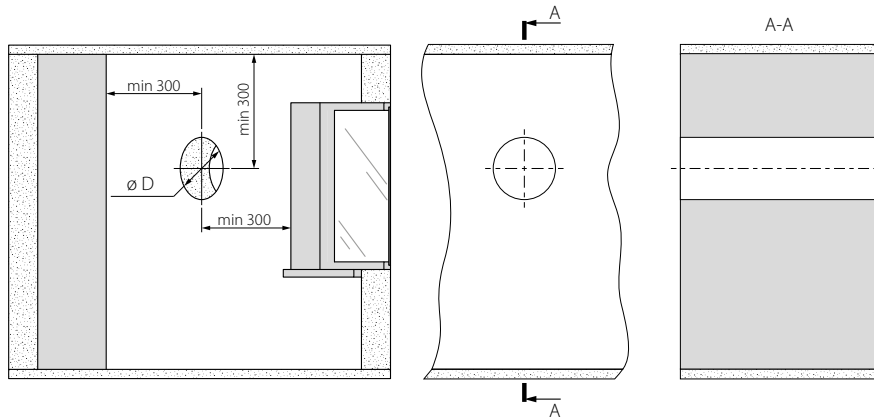

2. Install the air duct in the wall. For ease of installation use the mounting wedges included in the delivery set.

The air duct end must protrude for the distance A that enables installation of the outer ventilation hood. The overall dimensions of the outer ventilation hood, the outside protrusion length of the air duct A and the mounting sequence of the hood are stated in its installation instruction.

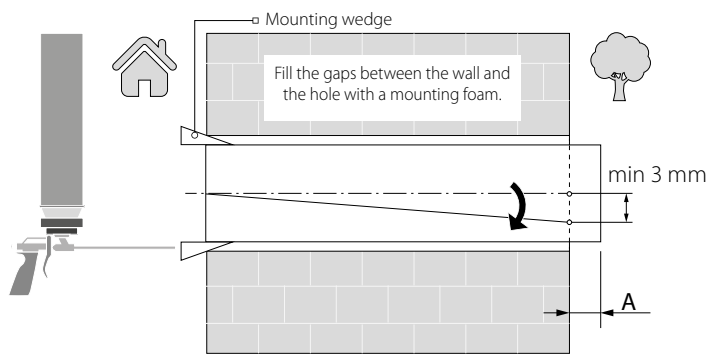

Install the air duct with the minimum slope of 3 mm downwards from the outer wall side.

The air duct can be cut by calculating preliminary the required length or after fixing the air duct on the wall (in this case, it is necessary to have access to the outside part of the wall).

3. Install the outer ventilation hood. The mounting sequence of the outer ventilation hood is described in the corresponding installation instruction.

3. Stick the delivered cardboard master plate on the indoor wall using a mounting tape. The large opening in the master plate must be axially aligned with the air duct. Align the master plate horizontally with a building level.

Then mark the fastening holes for installation of the supplied dowels and drill the holes to a required depth.

Route the power cable from the wall outside through the specially marked opening.

Hole marking for unit fastening

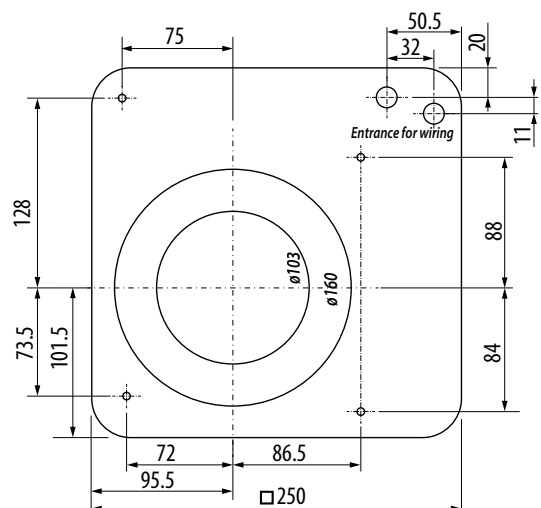
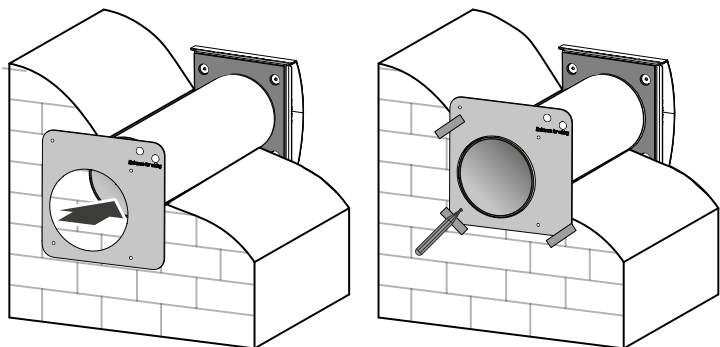

5. Separate the front panel of the indoor unit from its back part. To do this, press the round buttons on the top and bottom of the indoor unit simultaneously, as shown on the left in the figure below.

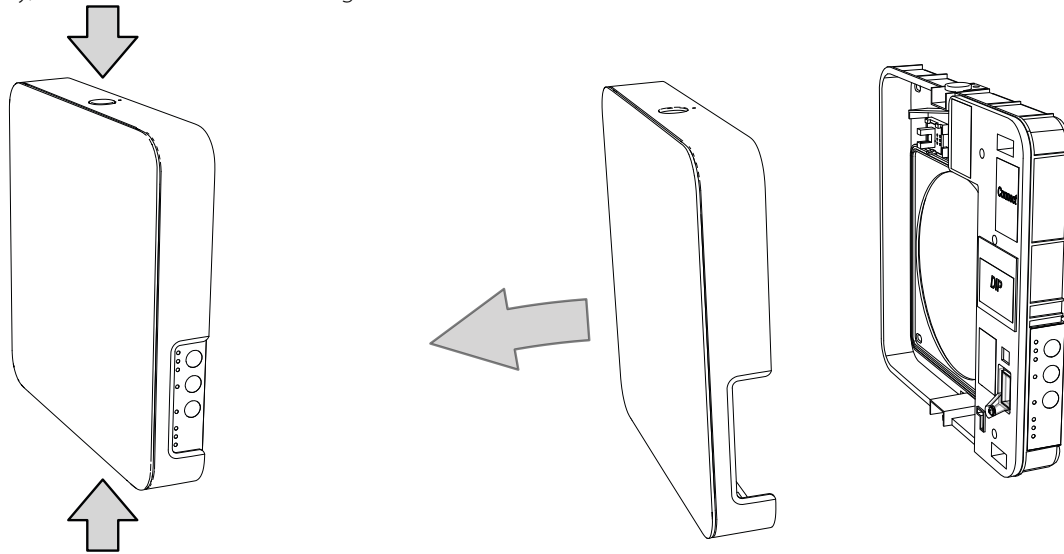

6. Remove the three retaining screws from the controller cover to enable access to the terminals. Route the power wires through the appropriate cable glands.

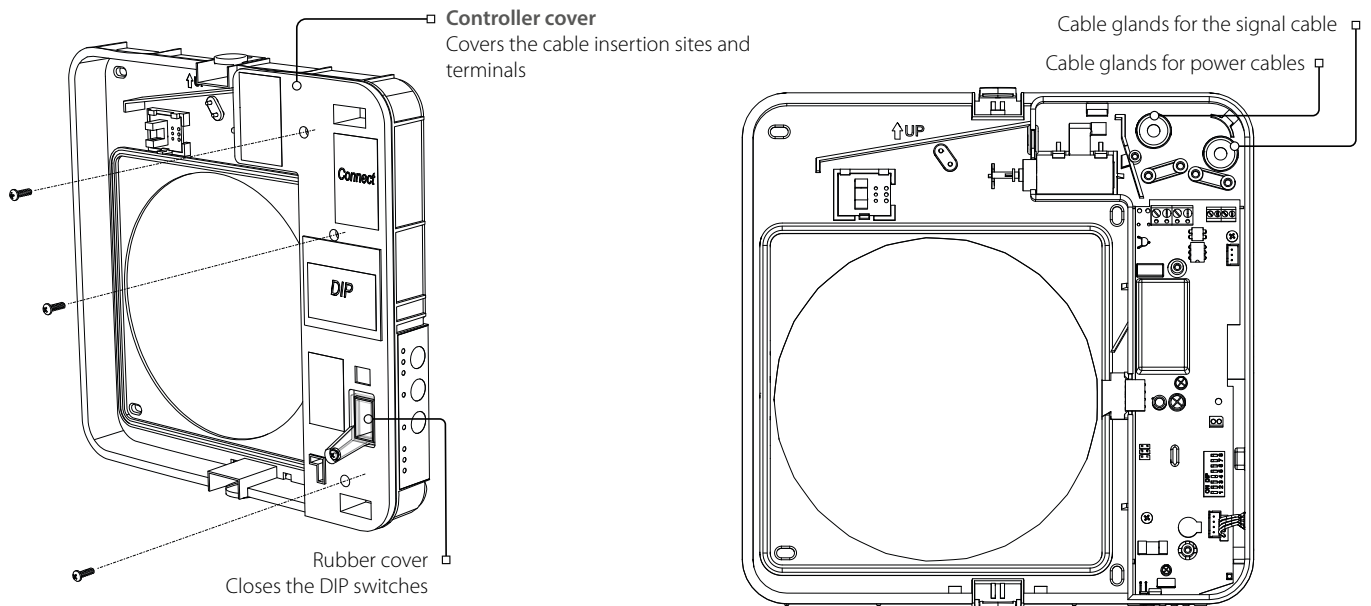

7. Fix the back part of the indoor unit on the wall with the screws supplied with the mounting kit of the ventilator.

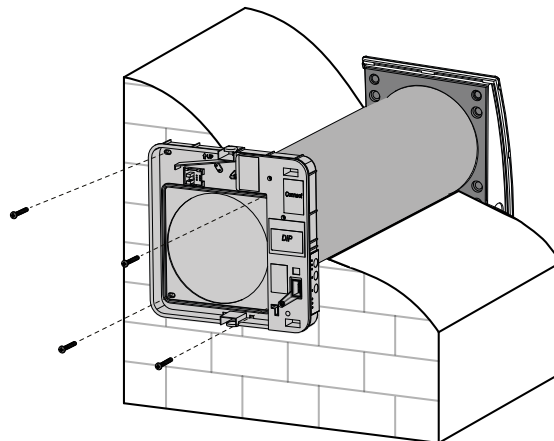

8. Route the power cable as figured below and connect the ventilator to power mains in compliance with the external wiring diagram, refer to the Connection to power mains section. Secure the cables in the new position with cable ties.

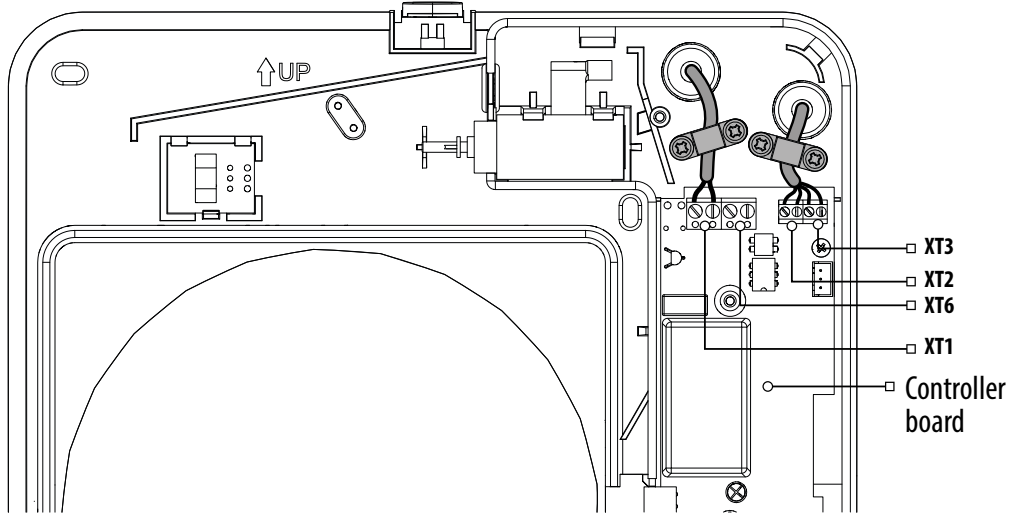

9. After completion of the electrical connection reinstall the controller cover in site.

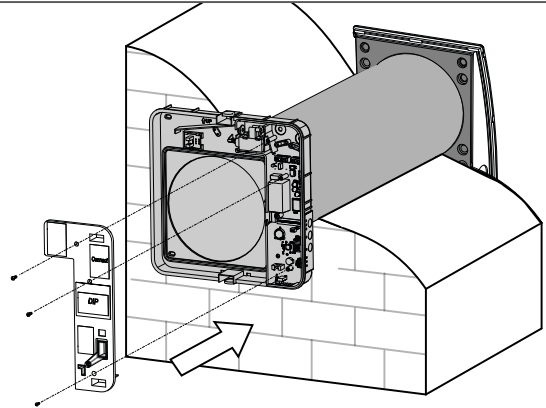

10. Install the cartridge or the regenerator unit and the fan unit into the air duct as figured below and connect the connector to the board as shown by the arrow.

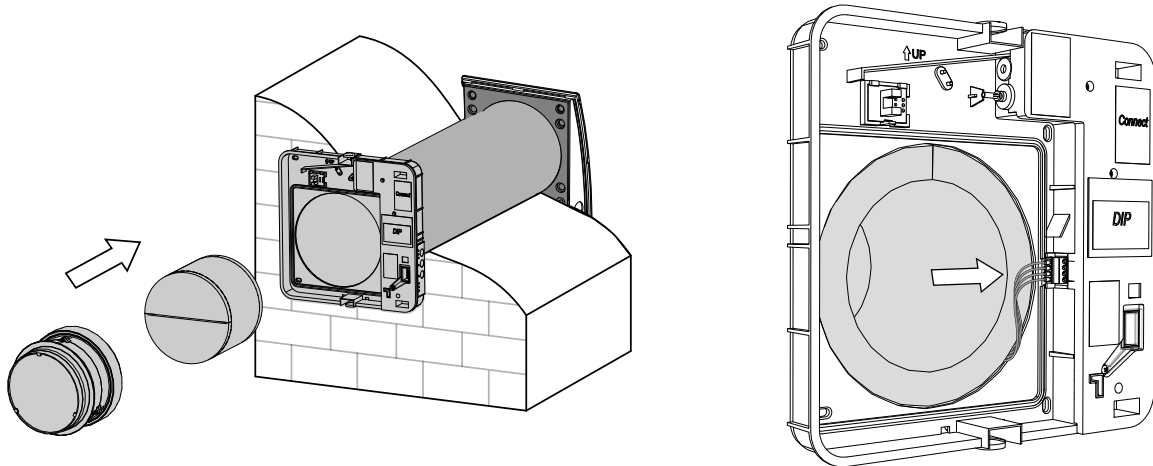

Insert the sound-absorbing layer into the air duct. Roll the layer of the sound-absorbing material to match the air duct diameter. The protecting paper layer must be outside. Insert the sound absorbing roll into the cartridge to match the slot. Make a mark at the end of the air duct, remove the material and cut the roll as marked. Insert the ready sound absorbing roll into the air duct.

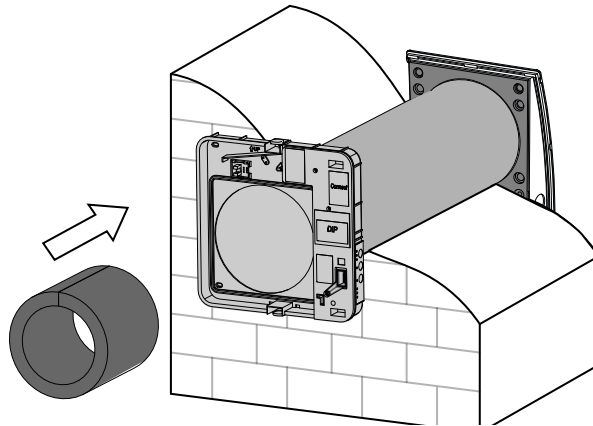

11. Install the front part of the indoor unit.

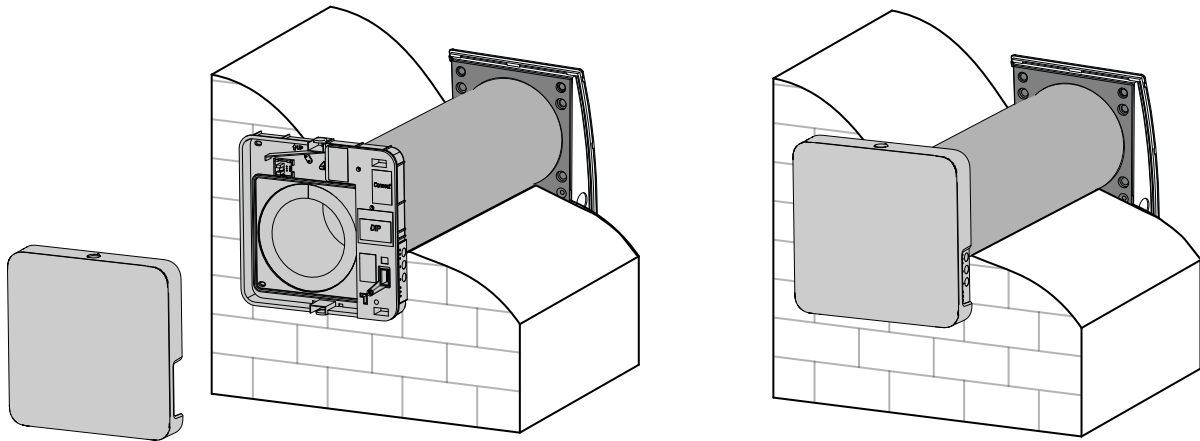

CONNECTION TO POWER MAINS

The ventilator is rated for connection to AC 100-240 V/50 (60) Hz power mains.

For electric installations use insulated, flexible conductors (cables, wires) with the minimum cross section of 0.5 up to 0.75 mm² for power cables and 0.25 mm² for sensor cables. The cable cross section is given for reference only. While selecting the required cable cross section consider the cable type, its maximum heating temperature, insulation, length and installation method. Use copper wires for all the electric connections!

Connect the unit to power mains via the terminal block installed in the controller board in compliance with the wiring diagram and terminal designation.

Connect the unit to power mains through the external automatic switch with a magnetic trip integrated into the fixed wiring system. The tripping current of the circuit breaker is selected based on the electrical characteristics shown on the label of the fan casing.

The ventilator design enables connecting any external controls with normally opened contacts (NO-contact), such as an external CO₂ sensor, a humidity sensor, a switch, etc. When the NO contact of the external device is closed, the ventilator switches to the maximum speed.

EXTERNAL CONNECTIONS DIAGRAM

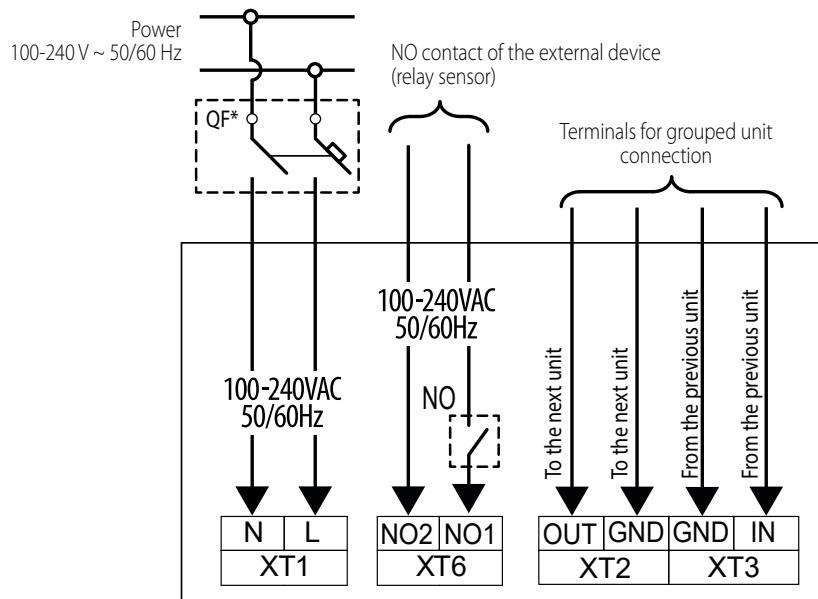

*The circuit breaker is not included in the delivery set.

Grouping the ventilators in a network

For group control over multiple ventilators, they need to be grouped in a network. A possible network grouping example is illustrated in the figure below. The ventilators can be connected in series and branching chains (ventilators No. 2 and No. 3 in the figure).

Warning! Do not connect more than two input cables to a single output when branching!

The network can only have one Master ventilator (it is determined as the one, whose **IN-terminal** is not connected).

Warning! The diagram in the figure below is an example intended to explain the possibility to connect ventilators for group control.

Each installation requires the layout to be determined based on the relative positions of the ventilators.

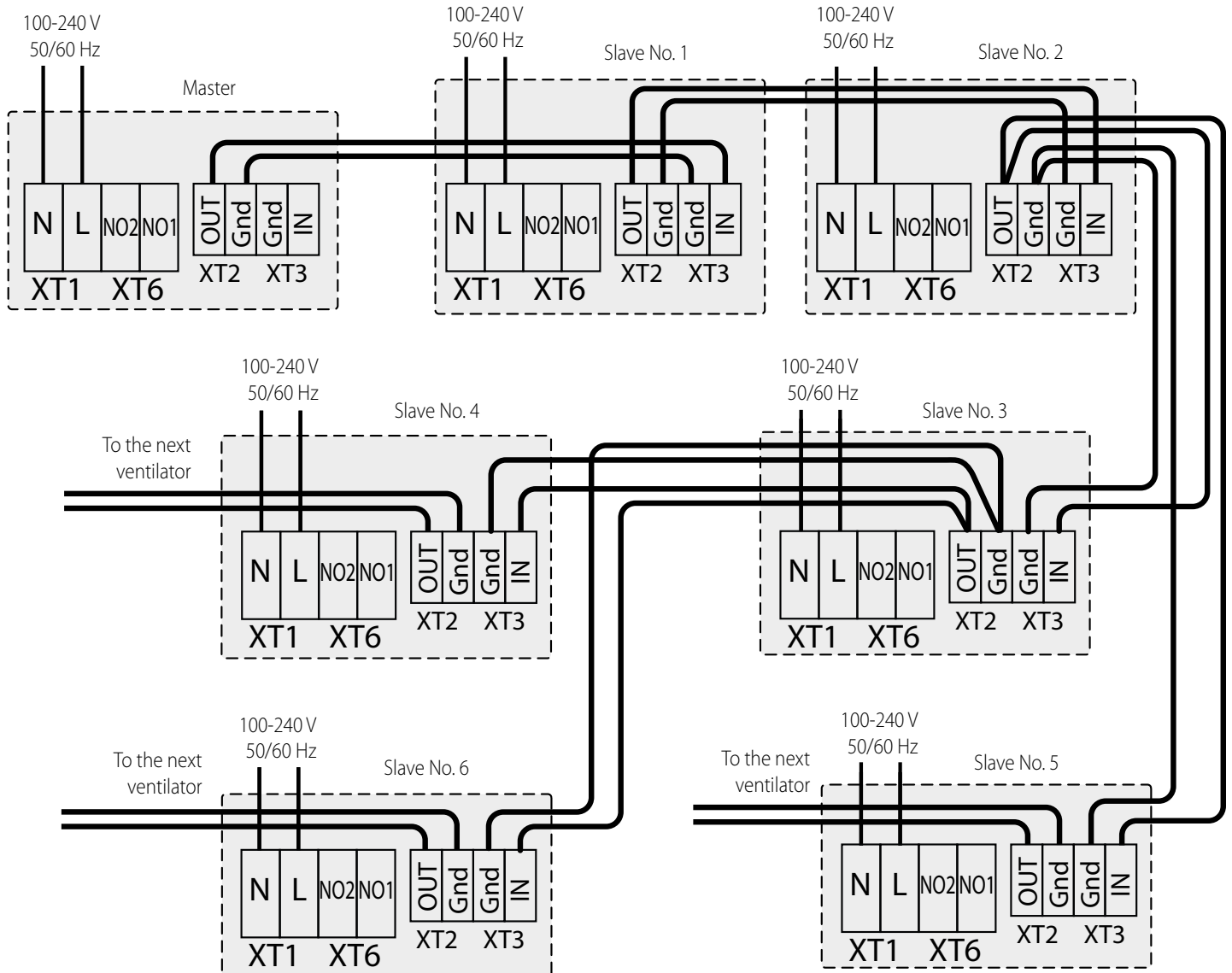

VENTILATOR SETUP

Prior to operating the ventilator set up the ventilator using the DIP switch. It is located on the controller circuit board. To access the DIP switch, take off the front panel of the indoor unit and uplift the rubber plug that covers the switch.

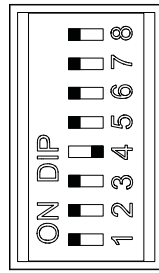
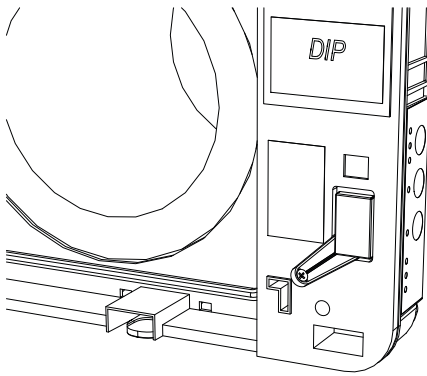

DIP switch under the cover

Positioning of the DIP switches

	1	The ventilator may be turned off. In this switch position, the ventilator can be turned off with the button on the side control panel.
	1	The ventilator may not be turned off. In this switch position, the ventilator cannot be turned off with the button on the side control panel.

Fan supply / extract mode switching It is necessary to use an even number of ventilators connected in a single network with a signal cable to ensure balanced ventilation. They must be set up in such a way that half of the ventilators operate in supply mode, and the other half operate in extract mode.

	2	In Ventilation mode the ventilator supplies the air to the room. In Regeneration mode the ventilator starts operating first in supply mode.
	2	In Ventilation mode the ventilator extracts the air from the room. In Regeneration mode the ventilator starts operating first in extract mode.

The humidity sensor preset value. The ventilator measures the humidity of the air that is extracted from the room. If the humidity exceeds the preset value, the ventilator switches to the third speed. After reaching the necessary air humidity level, the ventilator

Preset value																	
	5	Humidity control is disabled		5	40 %		5	50 %		5	60 %		5	70 %		5	80 %
	4			4			4			4			4				
	3			3			3			3			3				

Delay timer. The ventilator switches to a higher speed when the humidity sensor or an external device is triggered. After humidity or other parameters are back to normal, the ventilator switches to the previous operation mode in the preset time.

Delay time											
	7	0 min		7	5 min		7	15 min		7	30 min
	6			6			6			6	

Resetting the filter timer.	
	8 To reset the filter timer turn on the DIP switch for at least 3 seconds and turn it off.

VENTILATOR CONTROL

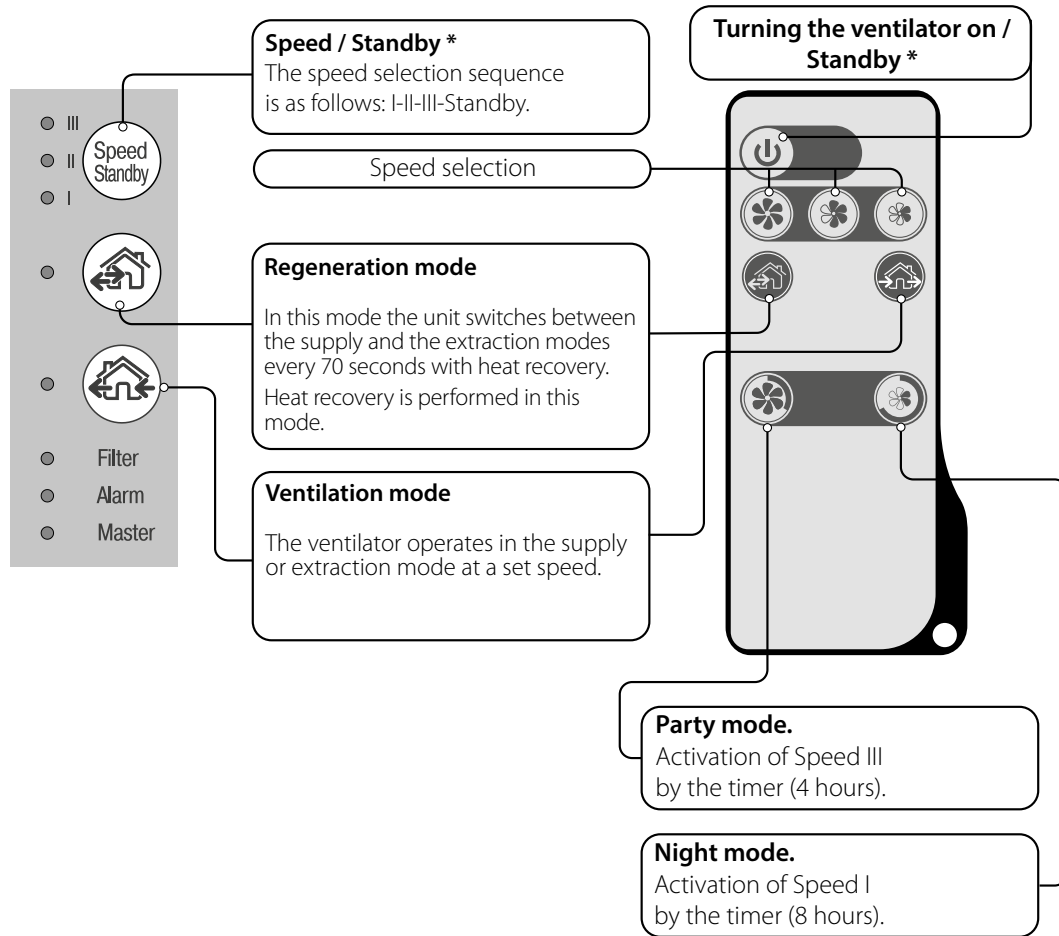

The ventilator is controlled with the remote control or keys on the side surface of the indoor unit (see the figure below). When ventilators are connected in a single network, the controls only impact the first (Master) ventilator.



* **Standby** button does not turn the unit off but switches it mode to standby mode only. During maintenance, it is mandatory to turn the unit off.







VENTILATOR CONTROL WITH THE BUTTONS ON THE INDOOR UNIT

The table below shows the buttons and indicators on the indoor ventilator unit with a detailed description of their purpose and functionality.

	<p>The ventilator speed selection sequence is as follows: I-II-III-Standby. All ventilators combined into one network run at the speed set by the master ventilator.</p> <p>I: permanent indicator glowing indicates operation of the unit at Speed I. The indicator blinks when the Night mode is activated.</p> <p>I and II: permanent glowing of the indicators I and II indicates operation of the unit at Speed II.</p> <p>I, II and III: permanent glowing of the indicators I, II and III indicates operation of the ventilator at Speed III. Blinking of the indicators I, II and III indicates activation of the timer in Party mode or the turn-off delay timer triggered by any connected external sensors or the integrated humidity sensor.</p>
	<p>Regeneration mode The rotation direction of the fan changes to opposite every 70 seconds. Heat recovery is performed in this mode.</p>
	<p>Ventilation mode The ventilator operates in permanent air supply or air extraction mode at set speed. The fan rotation direction depends on the DIP switch position (extract mode by default).</p>
<p>Filter</p>	<p>Contamination indicator of filters. 90 days (continuous operation) after installation of the cartridge the Filter contamination indicator starts glowing. In this case clean or replace the filters (see the "Technical maintenance" section). When connecting in series, the Master indicator of the first ventilator is lit up constantly, and the indicator of the ventilator requiring a filter change blinks. To reset the units' filter timer, switch on the DIP switch for at least 3 seconds and switch it off.</p>
<p>Alarm</p>	<p>Alarm indicator for emergency shutdown of the unit. Constant shining of the Alarm indicator of the Master unit indicates a fault in the network of the connected ventilation units. Its blinking indicates shutdown of a specific ventilation unit in the network. In case of an emergency shutdown of a series unit in the network the defective ventilation unit is marked with the blinking Alarm indicator. All the connected series ventilation units are also stopped..</p>
<p>Master</p>	<p>Master unit indicator. Permanent glowing of the indicator shows the leading unit in the network (Master unit). Indicator blinking indicates the driven unit (Slave unit) and no connection to the Master unit. No glowing of the lamp indicator means that this ventilation unit is a Slave ventilation unit and it is connected to a Master unit.</p>

Description of the buttons on the remote control "Turn-on/Standby"

The table below shows the buttons on the remote control with a detailed description of their purpose and functionality.

	<p>Turning the ventilator on / off. The ventilator can only be turned off if the ventilator settings enable it. Reset of alarm and timer settings.</p>
	<p>Selecting the ventilator speed: Speed III-II-I respectively.</p>
	<p>Regeneration mode In this mode, the rotation direction of the fan of this ventilator series changes to opposite every 70 seconds. Heat recovery is performed meanwhile.</p>
	<p>Ventilation mode. In this mode, the ventilator series' units supply or extract air at the selected speed. The air flow direction depends on the DIP switch position (extract mode by default).</p>
	<p>Timer control buttons:</p> <ul style="list-style-type: none">  Party mode: the timer activates operation of the ventilator at Speed III for 4 hours.  Night mode: the timer activates operation of the ventilator at Speed I for 8 hours. <p>The ventilation unit reverts to operation with a previous speed setting upon elapse of the set time period. Press any speed setting key to deactivate the timer.</p>

TECHNICAL MAINTENANCE



DISCONNECT THE UNIT FROM POWER SUPPLY BEFORE ANY MAINTENANCE OPERATIONS!
MAKE SURE THE UNIT IS DISCONNECTED FROM POWER MAINS BEFORE REMOVING THE PROTECTION.

Maintenance of the ventilator means regular cleaning of the ventilator surfaces of dust and cleaning and replacement of the filters. Upon elapse of the set filter service life (90 days) the Filter indicator starts shining. To access the basic assembly units follow the steps: turn off the ventilator using the remote control or the buttons on the indoor unit. Then turn the power off completely.

1. Remove the front panel of the indoor control unit as shown in section 5 Installation and Set-up.

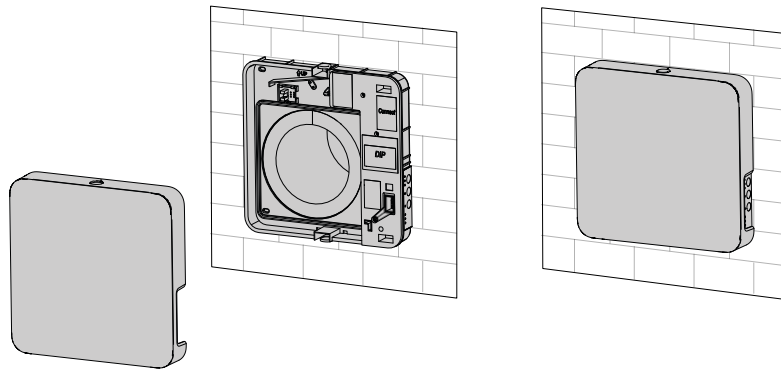

2. Disconnect the connector from the circuit board. Do not remove the connector by pulling the wires. Use a flat screwdriver to uplift it, if required.

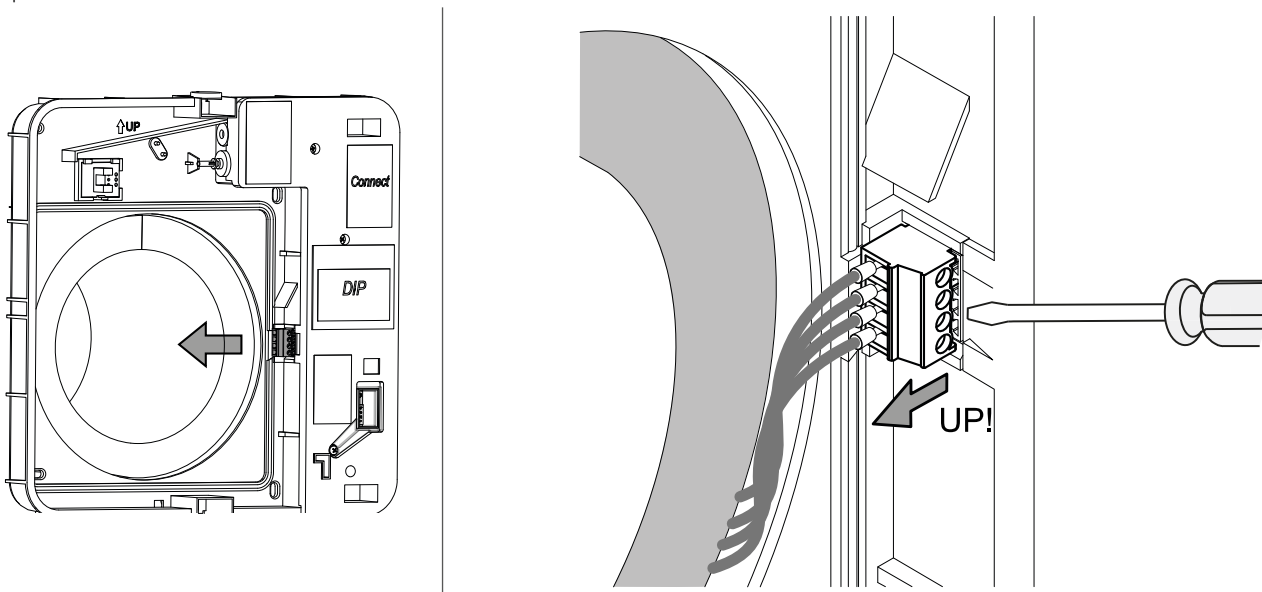

Remove the sound-insulation material from the duct, then remove the cartridge or the fan unit and the regenerator unit.

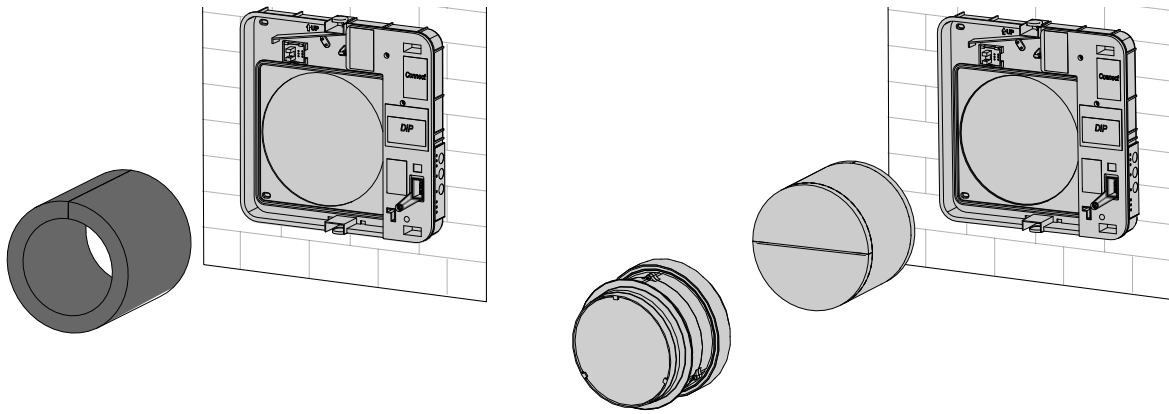

4. Clean the filters as they get clogged.

Depending on the dustiness of the air, the duration of the ventilator operation until the next filter cleaning may be different.

- Wash the filters and let those dry out completely.
- Install the dry filters in their place and assemble the unit in the reverse order.
- Vacuum cleaning is allowed.
- The filter rated service life is 3 years.

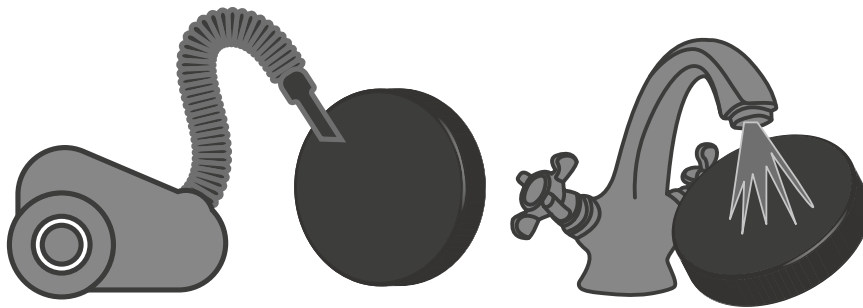

- Some dust may accumulate on the heat exchanger block even in case of regular maintenance of the filters.
- Clean the regenerator regularly to ensure its high heat recovery efficiency.
- Vacuum clean the regenerator at least once a year.

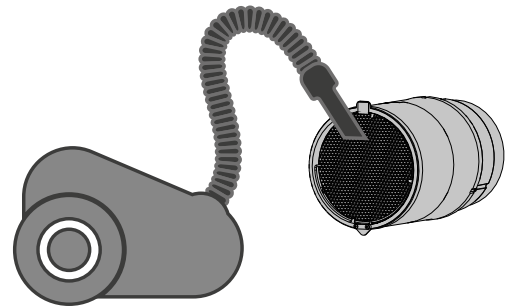

To reset the filter timer, power the ventilator via the circuit breaker and turn on the DIP switch No. 8 for at least 3 seconds before installing the front part of the indoor unit.

5. Replacement of the remote control battery (if necessary).

In case of a long operation of the remote control the battery must be replaced.

No response of the unit for pressing the remote control buttons indicates the need to replace the battery.

The battery type is CR2025.

Remove the holder with the battery from the lower part of the remote control.

Replace the battery and install the holder with a new battery back to the remote control.

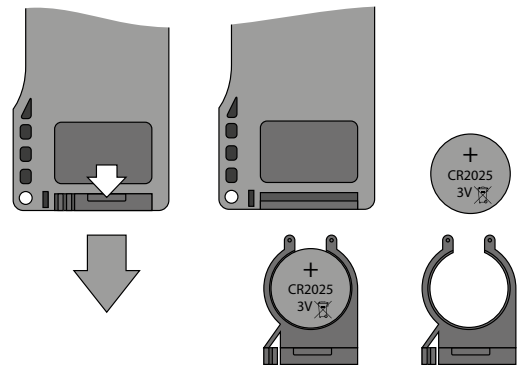

POSSIBLE REASONS AND TROUBLESHOOTING

Problem	Possible reasons	Troubleshooting
When switching on the ventilator, the fan does not start.	No power supply.	Make sure the power supply line is connected correctly, otherwise troubleshoot the connection error.
	The motor is jammed, the impeller blades are soiled.	Turn the ventilator off. Troubleshoot the motor jam and the impeller clogging. Clean the blades. Turn the ventilator on.
Circuit breaker tripping during the ventilation unit start-up.	Overcurrent as a result of short circuit in the electric circuit.	Turn the ventilator off. Contact the Seller for further information.
Low air flow.	Low set fan speed.	Set higher speed.
	The filters, the fan or the regenerator is clogged.	Clean or replace the filter. Clean the fan and the regenerator.
Noise, vibration.	The impeller is clogged.	Clean the impeller.
	Loose screw connection of the unit casing or the outer ventilation hood.	Tighten the screws of the ventilator or the outer ventilation hood.

STORAGE AND TRANSPORTATION REGULATIONS

- Store the unit in the manufacturer's original packaging box in a dry closed ventilated premise with temperature range from +5 °C to + 40 °C and relative humidity up to 70 %.
- Storage environment must not contain aggressive vapors and chemical mixtures provoking corrosion, insulation, and sealing deformation.
- Use suitable hoist machinery for handling and storage operations to prevent possible damage to the unit.
- Follow the handling requirements applicable for the particular type of cargo.
- The unit can be carried in the original packaging by any mode of transport provided proper protection against precipitation and mechanical damage. The unit must be transported only in the working position.
- Avoid sharp blows, scratches, or rough handling during loading and unloading.
- Prior to the initial power-up after transportation at low temperatures, allow the unit to warm up at operating temperature for at least 3-4 hours.

MANUFACTURER'S WARRANTY

The product is in compliance with EU norms and standards on low voltage guidelines and electromagnetic compatibility. We hereby declare that the product complies with the provisions of Electromagnetic Compatibility (EMC) Directive 2014/30/EU of the European Parliament and of the Council, Low Voltage Directive (LVD) 2014/35/EU of the European Parliament and of the Council and CE-marking Council Directive 93/68/EEC. This certificate is issued following test carried out on samples of the product referred to above.

The manufacturer hereby warrants normal operation of the unit for 24 months after the retail sale date provided the user's observance of the transportation, storage, installation, and operation regulations. Should any malfunctions occur in the course of the unit operation through the Manufacturer's fault during the guaranteed period of operation, the user is entitled to get all the faults eliminated by the manufacturer by means of warranty repair at the factory free of charge. The warranty repair includes work specific to elimination of faults in the unit operation to ensure its intended use by the user within the guaranteed period of operation. The faults are eliminated by means of replacement or repair of the unit components or a specific part of such unit component.

The warranty repair does not include:

- routine technical maintenance
- unit installation/dismantling
- unit setup

To benefit from warranty repair, the user must provide the unit, the user's manual with the purchase date stamp, and the payment paperwork certifying the purchase. The unit model must comply with the one stated in the user's manual. Contact the Seller for warranty service.

The manufacturer's warranty does not apply to the following cases:

- User's failure to submit the unit with the entire delivery package as stated in the user's manual including submission with missing component parts previously dismantled by the user.
- Mismatch of the unit model and the brand name with the information stated on the unit packaging and in the user's manual.
- User's failure to ensure timely technical maintenance of the unit.
- External damage to the unit casing (excluding external modifications as required for installation) and internal components caused by the user.
- Redesign or engineering changes to the unit.
- Replacement and use of any assemblies, parts and components not approved by the manufacturer.
- Unit misuse.
- Violation of the unit installation regulations by the user.
- Violation of the unit control regulations by the user.
- Unit connection to power mains with a voltage different from the one stated in the user's manual.
- Unit breakdown due to voltage surges in power mains.
- Discretionary repair of the unit by the user.
- Unit repair by any persons without the manufacturer's authorization.
- Expiration of the unit warranty period.
- Violation of the unit transportation regulations by the user.
- Violation of the unit storage regulations by the user.
- Wrongful actions against the unit committed by third parties.
- Unit breakdown due to circumstances of insuperable force (fire, flood, earthquake, war, hostilities of any kind, blockades).
- Missing seals if provided by the user's manual.
- Failure to submit the user's manual with the unit purchase date stamp.
- Missing payment paperwork certifying the unit purchase.



FOLLOWING THE REGULATIONS STIPULATED HEREIN WILL ENSURE A LONG AND TROUBLE-FREE OPERATION OF THE UNIT



USER'S WARRANTY CLAIMS SHALL BE SUBJECT TO REVIEW ONLY UPON PRESENTATION OF THE UNIT, THE PAYMENT DOCUMENT AND THE USER'S MANUAL WITH THE PURCHASE DATE STAMP

CERTIFICATE OF ACCEPTANCE

Unit Type	Single-room reversible energy recovery ventilator
Model	
Serial Number	
Manufacture Date	
Quality Inspector's Stamp	

SELLER INFORMATION

Seller	
Address	
Phone Number	
E-mail	
Purchase Date	
This is to certify acceptance of the complete unit delivery with the user's manual. The warranty terms are acknowledged and accepted.	
Customer's Signature	

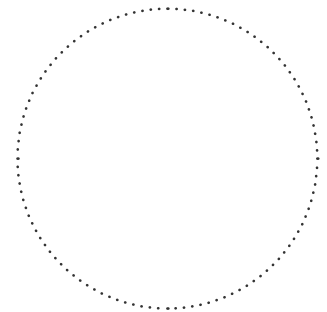

Seller's Stamp

INSTALLATION CERTIFICATE

The _____ unit is installed pursuant to the requirements stated in the present user's manual.	
Company name	
Address	
Phone Number	
Installation Technician's Full Name	
Installation Date:	Signature:
The unit has been installed in accordance with the provisions of all the applicable local and national construction, electrical and technical codes and standards. The unit operates normally as intended by the manufacturer.	
Signature:	

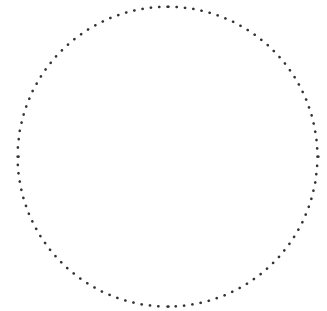

Installation Stamp

WARRANTY CARD

Unit Type	Single-room reversible energy recovery ventilator
Model	
Serial Number	
Manufacture Date	
Purchase Date	
Warranty Period	
Seller	

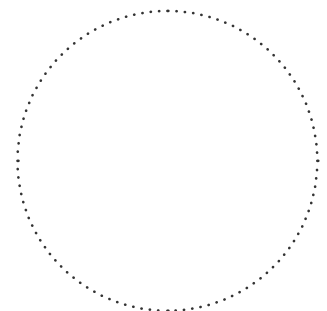

Seller's Stamp

