



VENTS

WWW. VENTILATION-SYSTEM.COM



ENERGY EFFICIENT



INNOVATIVE



SILENT



**INNOVATIVE
MIXED FLOW FANS**

2013



INNOVATIVE INLINE MIXED FLOW FANS

Following the latest worldwide ventilation trends, we developed a new inline mixed-flow fan **VENTS TT PRO series**. The specially designed optimized case and the aerodynamic impeller ensure the best combination of high air capacity, powerful pressure and low noise level.

Due to the new high-efficient motor the fan has low energy demand but excellent aerodynamics. Outstanding technical data and the compact size make our new product a really revolutionary fan suitable for various air handling systems applied in residential and commercial premises.



ARE YOU INTERESTED IN EFFECTIVE VENTILATION IN YOUR HOUSE WITH MINIMUM INVESTMENT AND OPERATING COSTS?



- ▶ HIGH PERFORMANCE: up to 2050 m³/h
- ▶ HIGH PRESSURE
- ▶ ENERGY EFFICIENT: 23 – 320 W
- ▶ SILENT OPERATION: 27 – 58 dB(A)

Owing to the collector located in the intake spigot the air stream flows smoothly to the fan case.

The hemispheric shaped impeller with specially profiled blades is designed to ensure the unique combination of powerful airflow of axial fan and high pressure of centrifugal one.

The directing vanes at outlet from the fan convert the dynamic pressure originated by air swirling behind the impeller into static pressure that results in higher static pressure and general fan performance increase.



YOUR IDEAL SOLUTION!

Application



- Bathrooms
- Kitchens
- Apartments
- Cottages
- Pools
- Stores
- Restaurants



- Bars
- Offices
- Libraries
- Galleries
- Public institutions
- Conference halls
- Education facilities



THE BEST CHOICE FOR POWERFUL HIGH PRESSURE SOUND-INSULATED VENTILATION

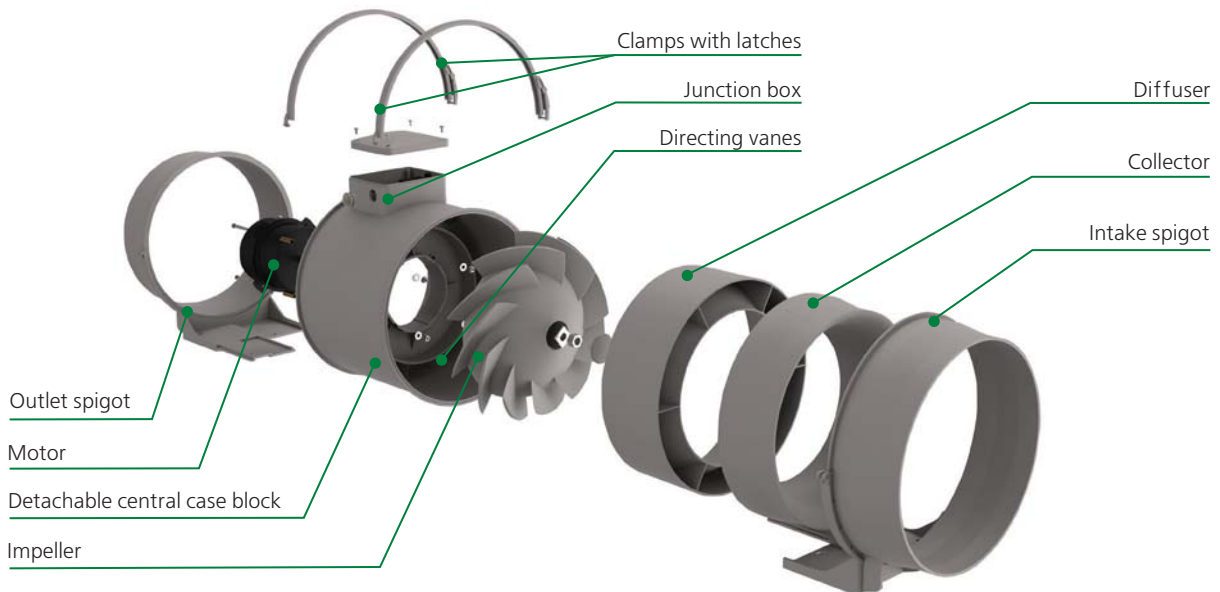

Design

- The special aerodynamic case made of high-quality durable plastic.
- The inlet spigot is fitted with a collector for smooth airflow into the fan.
- The diffuser, specially designed impeller and directing vanes at the fan outlet distribute the airstream in such a way as to provide the optimum combination of high air capacity, powerful pressure even at low noise level.



- The detachable central block with motor, impeller and junction box is connected to the spigots through hose clamps with latches. This design solution makes the fan maintenance very easy and convenient. Forget about dismantling or disassembling! Just remove the central block from the case and complete the servicing!

Motor

- The fan is equipped with a high-efficient double-speed capacitor motor.
- The ball bearings extend the motor service life up to **40 000 hrs** at non-stop operation.
- The motors are equipped with thermal overheating protection. Motor protection IP 44.

Speed control

VENTS TT PRO ... V – the fan with a built-in three-position speed switch. A TRIAC or autotransformer speed controller (available upon separate order) are used for smooth speed control with the speed controller connected to the maximum speed terminal.



Speed control options

VENTS TT PRO ... U – the fan includes a speed controller with temperature sensor that allows automatic speed (air flow) regulation as a function of the indoor temperature. The fan has a modification with a temperature sensor integrated into the air duct (**TT PRO...U**) as well as modification with an external temperature sensor (**TT PRO...Un**) fixed on the cable 4 m.



VENTS TT PRO ... P – the fan with a built-in speed controller for smooth speed control from 0 to 100% and a power cord with a plug.



Mounting

- The fans are suitable for mounting at any angle and point of the system.
- The fan case is equipped with a mounting plate to attach the fan to the wall.
- The central case block with the junction box may be installed in any position to facilitate mounting and wiring.

Technical data

	TT PRO 100		TT PRO 125		TT PRO 150 TT PRO 160		TT PRO 200		TT PRO 250		TT PRO 315	
Speed	min.	max.	min.	max.	min.	max.	min.	max.	min.	max.	min.	max.
Voltage [V / 50 / 60 Hz]	1~ 230		1~ 230		1~ 230		1~ 230		1~ 230		1~ 230	
Power [W]	23	25	25	30	42	50	76	108	125	177	230	320
Current [A]	0,10	0,11	0,11	0,13	0,19	0,22	0,34	0,48	0,54	0,79	1,0	1,42
Maximum air flow [m ³ /h]	180	245	240	350	415	565	830	1040	1110	1400	1570	2050
RPM [min ⁻¹]	2050	2620	1630	2300	1940	2620	1915	2380	1955	2440	1890	2430
Noise level at 3 m [dBA]	27	32	29	34	37	46	45	52	47	55	49	58
Maximum operating temperature [°C]	60		60		60		60		60		60	
Protection rating	IP X4		IP X4		IP X4		IP X4		IP X4		IP X4	

Fan overall dimensions

Type	Dimensions [mm]				Mass [kg]
	∅D	B	H	L	
TT PRO 100	97	195,8	226	302,5	1,54
TT PRO 125	123	195,6	226	258,5	1,51
TT PRO 150	148	220,1	247	289	2,1
TT PRO 160	158	220,1	247	289	2,2
TT PRO 200	199	239	261	295,5	6,4
TT PRO 250	247	287	323	383	8,3
TT PRO 315	310	362	408	445	11,4

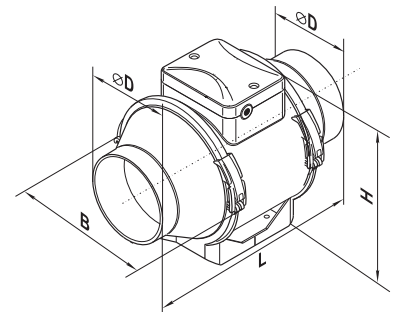

Aerodynamic characteristics

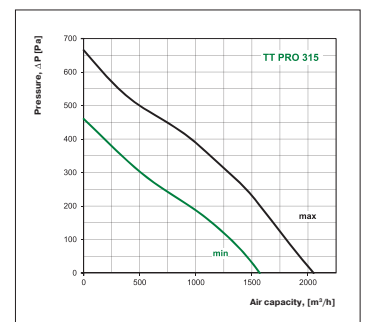
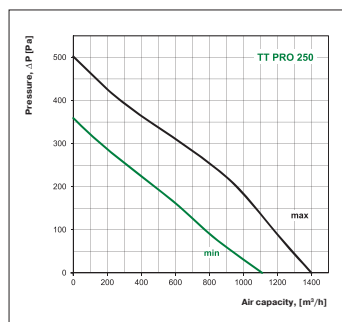
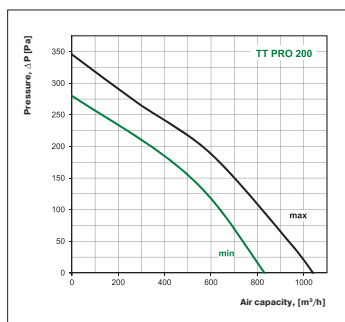
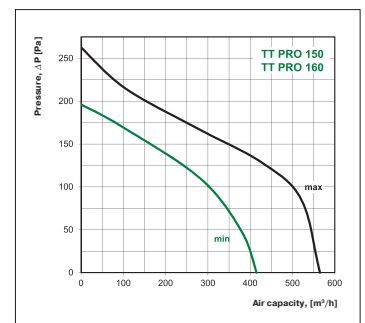
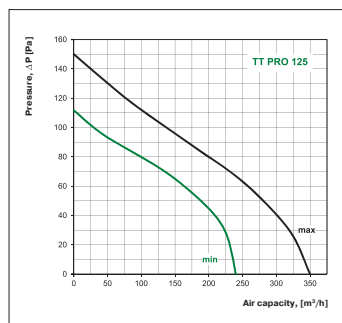
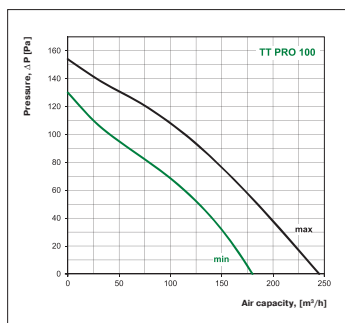

Information in the leaflet is for reference only. VENTS reserves the right to modify any of its products' features, designs, components and specifications at any time and without notice to maintain the development and quality of manufactured goods.